

# 24" Recessed Handle Special Application

300 Series – White SGE53U52UC



**SGE53U52UC**  
White

Also available in:  
Stainless Steel SGE53U55UC  
Black SGE53U56UC

**Bosch dishwashers incorporate 18 unique sound-reducing technologies, to make Bosch the quietest dishwasher brand in the US.**

## Features & Benefits

46 dBA: Quietest dishwasher brand.

Water softener ensures optimally spot-free and shiny dishes.

RackMatic® offers 3 height levels, for 9 possible rack positions.

AquaStop® Plus 4-Part leak protection prevents water damage 24/7.

24h Delay Start Timer lets you run your dishwasher at off-peak times.

## General Properties

Number of wash cycles	4
Number of options	4
dBA	46
Third rack	No
Rack adjustability	RackMatic®
Tub material	Stainless steel
Control type	Buttons
Concealed heating element	Yes
Leak protection system	24/7 AquaStop® Plus
Water softener	Yes
Five-level wash	Yes
ChildLock	Yes
Special features	24h delay start timer

## Efficiency

Water usage per cycle	3.0
Energy efficiency class	Tier 1
ENERGY STAR® qualified	Yes
Total annual energy consumption (kWh)	259 kWh
Total annual water consumption (g)	645

## Capacity

Number of place settings	14
--------------------------	----

## Technical Details

Watts (W)	1300 W
Current (A)	12 Amps
Volts (V)	120 V
Frequency (Hz)	60 Hz
Power cord length	68 7/8"
Minimum water pressure (lb/sin)	7
Length inlet hose (in)	65"
Length outlet hose (in)	74 7/8"

## Dimensions & Weight

Overall appliance dimensions (HxWxD) (in)	32 1/16" x 23 9/16" x 22 9/16"
Required cutout size (HxWxD) (in)	32 1/8" x 24" x 24"
Adjustable feet	Yes
Net weight (lbs)	84 lbs

## Accessories—Optional

Dishwasher Softener Salt (4.4 lbs)	SGZ9091UC
Dishwasher Supply and Drainage Hose Extension 76 3/4"	SGZ1010UC
Dishwasher Accessory Kit	SMZ5000
Anti-tarnish Silverware Cassette	SMZ5002



**For help and assistance with Bosch accessories please call 1-800-944-2904 Mon-Fri 8am to 6pm EST**

Notes: All height, width and depth dimensions are shown in inches. BSH reserves the absolute and unrestricted right to change product materials and specifications, at any time, without notice. Consult the product's installation instructions for final dimensional data and other details prior to making cutout. Applicable product warranty can be found in accompanying product literature or you may contact your account manager for further details.

Warranties: Bosch warrants that the Product is free from defects in materials and workmanship for a period of three hundred and sixty-five (365) days from the date of purchase. The foregoing timeline begins to run upon the date of purchase, and shall not be stalled, tolled, extended, or suspended, for any reason whatsoever. This Product is also warranted to be free from cosmetic defects in material and workmanship (such as scratches of stainless steel, paint/porcelain blemishes, chip, dents, or other damage to the finish) of the Product, for a period of thirty (30) days from the date of purchase or closing date for new construction. This cosmetic warranty excludes slight color variations due to inherent differences in painted and porcelain parts, as well as differences caused by kitchen lighting, product location, or other similar factors. This cosmetic warranty specifically excludes any display, floor, "As Is", or "B" stock appliances.

**For more information on our entire line of products, go to [www.bosch-home.ca](http://www.bosch-home.ca) or call 1-800-944-2904**

© BSH Home Appliances Limited. All rights reserved. Bosch is a registered trademark of Robert Bosch GmbH.

09/15

# 24" Recessed Handle Special Application

300 Series – White SGE53U52UC



## Installation Details

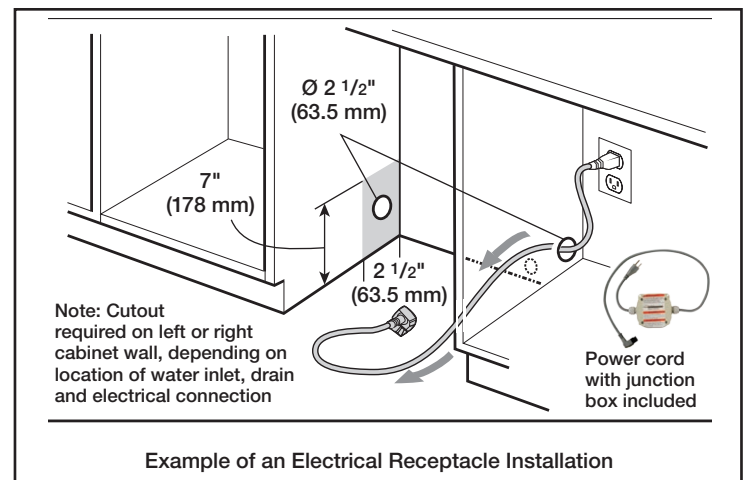
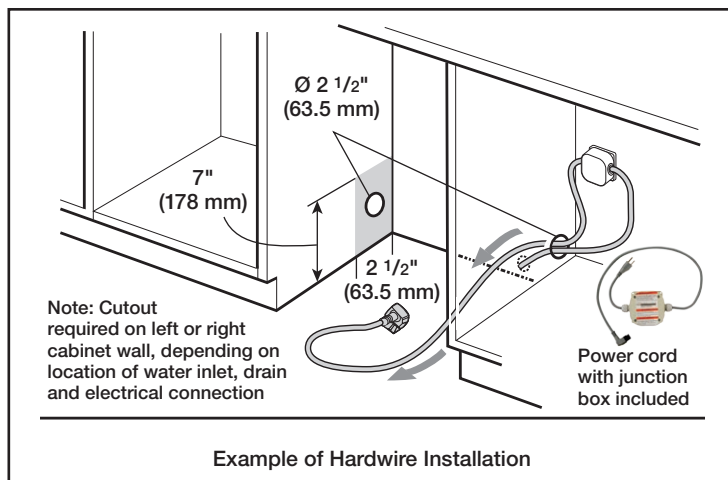
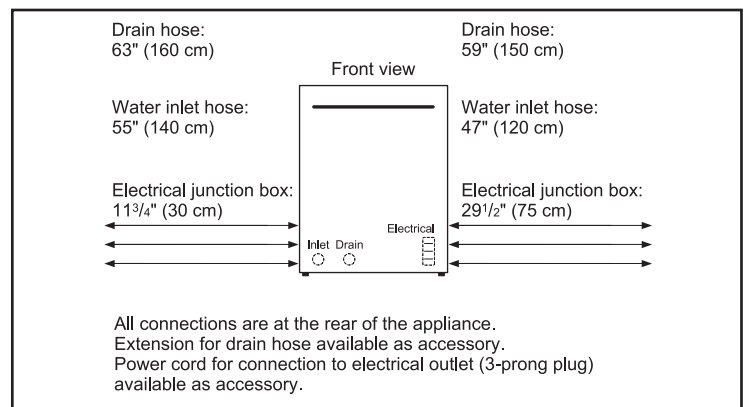
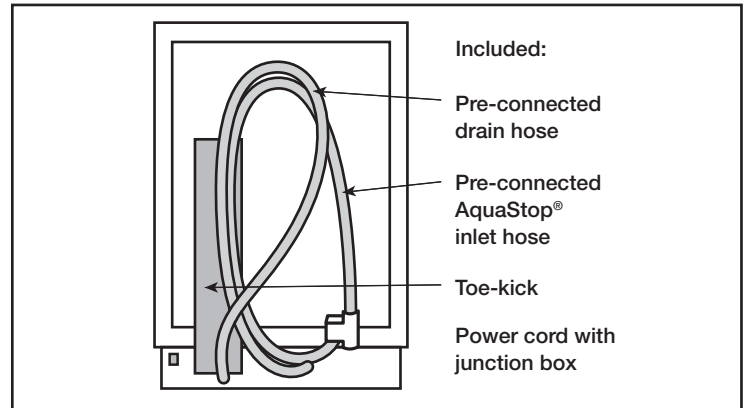
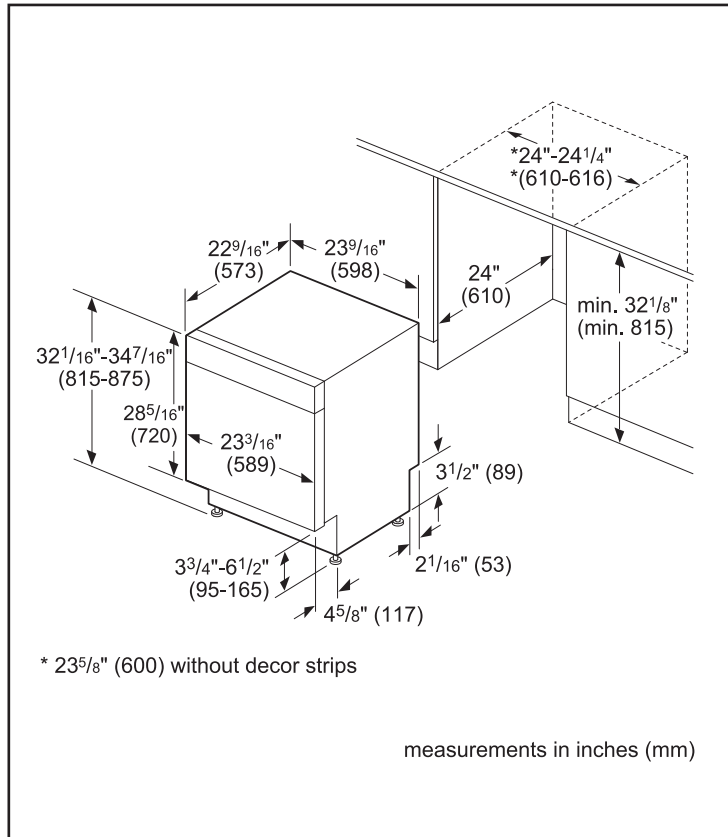

For help and assistance with Bosch accessories please call 1-800-944-2904 Mon-Fri 8am to 6pm EST

Notes: All height, width and depth dimensions are shown in inches. BSH reserves the absolute and unrestricted right to change product materials and specifications, at any time, without notice. Consult the product's installation instructions for final dimensional data and other details prior to making cutout. Applicable product warranty can be found in accompanying product literature or you may contact your account manager for further details.

Warranties: Bosch warrants that the Product is free from defects in materials and workmanship for a period of three hundred and sixty-five (365) days from the date of purchase. The foregoing timeline begins to run upon the date of purchase, and shall not be stalled, tolled, extended, or suspended, for any reason whatsoever. This Product is also warranted to be free from cosmetic defects in material and workmanship (such as scratches of stainless steel, paint/porcelain blemishes, chip, dents, or other damage to the finish) of the Product, for a period of thirty (30) days from the date of purchase or closing date for new construction. This cosmetic warranty excludes slight color variations due to inherent differences in painted and porcelain parts, as well as differences caused by kitchen lighting, product location, or other similar factors. This cosmetic warranty specifically excludes any display, floor, "As Is", or "B" stock appliances.

For more information on our entire line of products, go to [www.bosch-home.ca](http://www.bosch-home.ca) or call 1-800-944-2904

© BSH Home Appliances Limited. All rights reserved. Bosch is a registered trademark of Robert Bosch GmbH.

09/15

# 24" Recessed Handle Special Application

300 Series – White SGE53U52UC



## Installation Details

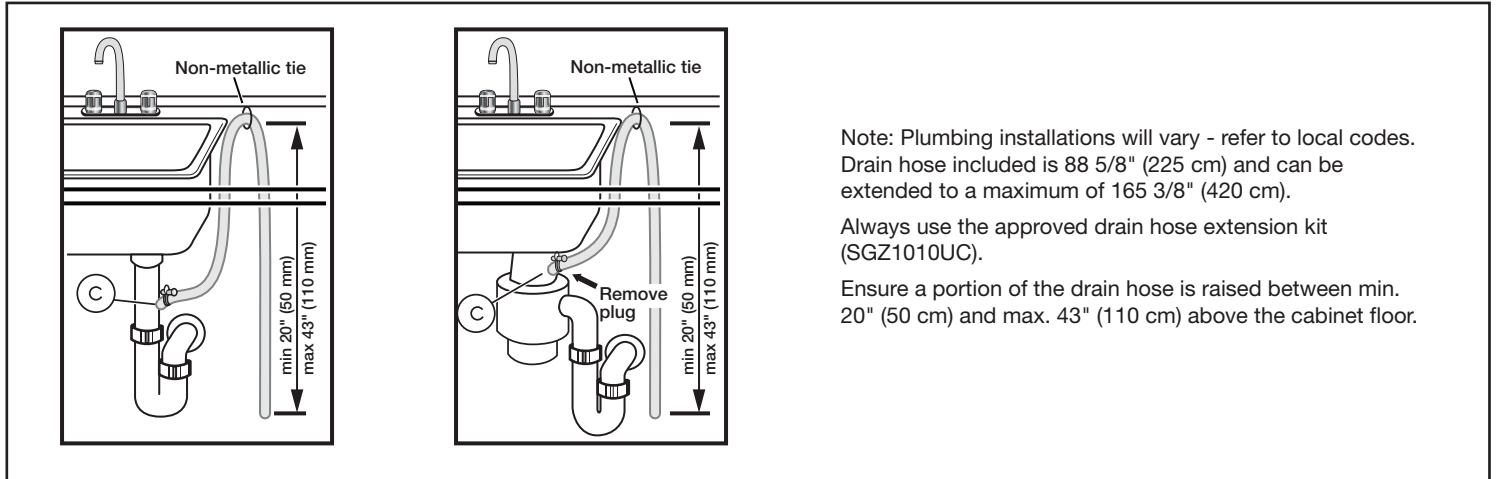

Note: Plumbing installations will vary - refer to local codes. Drain hose included is 88 5/8" (225 cm) and can be extended to a maximum of 165 3/8" (420 cm).

Always use the approved drain hose extension kit (SGZ1010UC).

Ensure a portion of the drain hose is raised between min. 20" (50 cm) and max. 43" (110 cm) above the cabinet floor.

**For help and assistance with Bosch accessories please call 1-800-944-2904 Mon-Fri 8am to 6pm EST**

Notes: All height, width and depth dimensions are shown in inches. BSH reserves the absolute and unrestricted right to change product materials and specifications, at any time, without notice. Consult the product's installation instructions for final dimensional data and other details prior to making cutout. Applicable product warranty can be found in accompanying product literature or you may contact your account manager for further details.

Warranties: Bosch warrants that the Product is free from defects in materials and workmanship for a period of three hundred and sixty-five (365) days from the date of purchase. The foregoing timeline begins to run upon the date of purchase, and shall not be stalled, tolled, extended, or suspended, for any reason whatsoever. This Product is also warranted to be free from cosmetic defects in material and workmanship (such as scratches of stainless steel, paint/porcelain blemishes, chip, dents, or other damage to the finish) of the Product, for a period of thirty (30) days from the date of purchase or closing date for new construction. This cosmetic warranty excludes slight color variations due to inherent differences in painted and porcelain parts, as well as differences caused by kitchen lighting, product location, or other similar factors. This cosmetic warranty specifically excludes any display, floor, "As Is", or "B" stock appliances.

**For more information on our entire line of products, go to [www.bosch-home.ca](http://www.bosch-home.ca) or call 1-800-944-2904**

© BSH Home Appliances Limited. All rights reserved. Bosch is a registered trademark of Robert Bosch GmbH.

09/15