

24 " Recessed Handle Dishwasher

800 Plus Series- Stainless steel

SHE9ER55UC



Features and Benefits

Key Features

- 39 dBA- Quietest in North America
- 3rd Rack for Additional Loading Capacity
- ActiveTab™ Tray Optimizes Detergent Dissolving
- Water Softener Ensures Perfect Cleaning Results
- AquaStop® Plus 4-Part Leak Protection Works 24/7
- Load Size Sensor Automates Wash Temperature
- Red Colored Full Text Display

Design

- Stainless Steel TallTub
- Real Stainless Steel Fascia Panel
- Red Colored Full Text Display

Performance

- 39 dBA- Quietest in North America
- 4 Wash Cycles and 2 Options
- Sanitize Option eliminates bacteria and enhances drying results
- Variable Spray Pressure
- ActiveTab™ Tray Optimizes Detergent Dissolving
- Water Softener Ensures Perfect Cleaning Results
- Load Size Sensor Automates Wash Temperature

Efficiency

- Saves up to 436 gallons of water each year
- 200 kwh/yr - Energy Star®
- Exceeds ENERGY STAR Requirements for Water by 125%



Notes: All height, width and depth dimensions are shown in inches. *Please refer to installation instructions prior to making cutout. BSH reserves the absolute and unrestricted right to change product materials and specifications, at any time, without notice. Consult the product's installation instructions for final dimensional data and other details. Applicable product warranty can be found in a accompanying product literature or you may contact your account manager for further details.

For more information on our entire line of products, go to boschappliances.com or call 1-800-944-2904.
Copyright ©2013 BSH Home Appliances Corporation. All rights reserved. Bosch is a registered trademark of Robert Bosch GmbH.

Litho Date: 04/2013



24 " Recessed Handle Dishwasher

800 Plus Series- Stainless steel

SHE9ER55UC

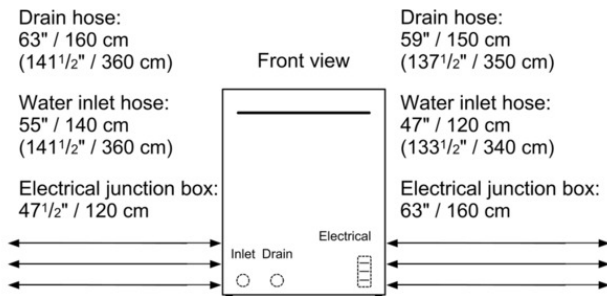

All connections in the rear of the appliance.
() values with extension kit.

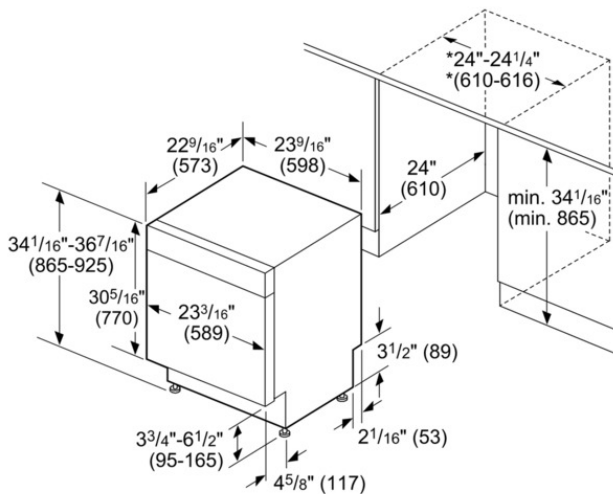

*23 5/8" (600) without decor strips

measurements in inches (mm)

Features

Leak Protection System	24/7 Aqua Stop Plus
ChildLock	Yes
Water softener	Yes
Upper Rack	high
Adjustable upper rack	Rackmatic 3-stage
Upper rack cup shelf	2
Lower Rack	high
Lower rack cup shelf	2
3rd Rack	3rd Rack 1.0
Silverware basket	Standard
Optional accessories	SGZ1010, SGZ9091UC, SMZ2014, SMZ5000, SMZ5002, SMZ5100

Technical Specification

UPC code	825225800385
Panel ready	No
Alternative colors available	
Silence level (dBA)	39
Watts (W)	1300
Current (A)	12
Volts (V)	120
Frequency (Hz)	60
Energy Consumption (kWh/yr)	200
Energy Star® qualified	Yes
NSF certified	No
Plug type	120V-3 prong
Power cord length (in)	47 1/4"
Length outlet hose (in)	55 1/8 "
Length inlet hose (in)	55 1/8"
Required cutout size (HxWxD) (in)	34 1/16" x 24 " x 24 "
Product packaging dimensions (HxWxD) (in)	36 7/16" x 26" x 26 3/4"
Net weight (lbs)	119
Gross weight (lbs)	123
Adjustable feet	Yes
Tube material	Stainless steel
Tube type	TallTube
ADA Compliant	No
Number of place settings	14

Notes: All height, width and depth dimensions are shown in inches. *Please refer to installation instructions prior to making cutout. BSH reserves the absolute and unrestricted right to change product materials and specifications, at any time, without notice. Consult the product's installation instructions for final dimensional data and other details. Applicable product warranty can be found in a accompanying product literature or you may contact your account manager for further details.

For more information on our entire line of products, go to boschappliances.com or call 1-800-944-2904.

Copyright ©2013 BSH Home Appliances Corporation. All rights reserved. Bosch is a registered trademark of Robert Bosch GmbH.

Litho Date: 04/2013

