

24" Pocket Handle Dishwasher

800 Series – Stainless Steel SHP68T55UC



SHP68T55UC
Stainless Steel

The 3rd rack offers 30% more loading area. Perfect for ramekins, cooking utensils and extra-long silverware.

Features & Benefits

44 dBA: Quietest dishwasher brand.

3rd rack adds versatility and offers 30% more loading capacity.

Touch Control Technology allows for quick cycle programming.

InfoLight® shines on the floor so you know the dishwasher's running.

RackMatic® offers 3 height levels, for 9 possible rack positions.

General Properties

Number of wash cycles	6
Number of options	5
dBA	44
Third rack	Standard
Rack adjustability	RackMatic®
Tub material	Stainless steel
Control type	Touch Control
Concealed heating element	Yes
Leak protection system	24/7 AquaStop®
Water softener	No
Five-level wash	Yes
ChildLock	No
Special features	InfoLight®, Eco Cycle

Efficiency

Water usage per cycle	2.9
Energy efficiency class	Tier 1
ENERGY STAR® qualified	Yes
Total annual energy consumption (kWh)	259
Total annual water consumption (g)	624

Capacity

Number of place settings	16
--------------------------	----



Technical Details

Watts (W)	1300 W
Current (A)	12 Amps
Volts (V)	120 V
Frequency (Hz)	60 Hz
Power cord length	43 1/2"
Minimum water pressure (lb/sin)	14
Length inlet hose (in)	53"
Length outlet hose (in)	67"

Dimensions & Weight

Overall appliance dimensions (HxWxD) (in)	33 7/8" x 23 9/16" x 23 3/4"
Required cutout size (HxWxD) (in)	33 7/8" x 23 5/8" x 24"
Adjustable feet	Yes
Net weight (lbs)	91 lbs

Accessories—Optional

Dishwasher Drain Hose Extension 76 3/4"	SGZ1010UC
Dishwasher 3-Prong Power Cord 66 7/8"	SMZPC002UC
Dishwasher Accessory Kit	SMZ5000
DoubleFlex Silverware Basket	SMZ4000UC



For help and assistance with Bosch accessories please call 1-800-944-2904 Mon-Fri 8am to 6pm EST

Notes: All height, width and depth dimensions are shown in inches. BSH reserves the absolute and unrestricted right to change product materials and specifications, at any time, without notice. Consult the product's installation instructions for final dimensional data and other details prior to making cutout. Applicable product warranty can be found in accompanying product literature or you may contact your account manager for further details.

Warranties: Bosch warrants that the Product is free from defects in materials and workmanship for a period of three hundred and sixty-five (365) days from the date of purchase. The foregoing timeline begins to run upon the date of purchase, and shall not be stalled, tolled, extended, or suspended, for any reason whatsoever. This Product is also warranted to be free from cosmetic defects in material and workmanship (such as scratches of stainless steel, paint/porcelain blemishes, chip, dents, or other damage to the finish) of the Product, for a period of thirty (30) days from the date of purchase or closing date for new construction. This cosmetic warranty excludes slight color variations due to inherent differences in painted and porcelain parts, as well as differences caused by kitchen lighting, product location, or other similar factors. This cosmetic warranty specifically excludes any display, floor, "As Is", or "B" stock appliances.

For more information on our entire line of products, go to www.bosch-home.ca or call 1-800-944-2904

© BSH Home Appliances Limited. All rights reserved. Bosch is a registered trademark of Robert Bosch GmbH.

24" Pocket Handle Dishwasher

800 Series – Stainless Steel SHP68T55UC



Installation Details

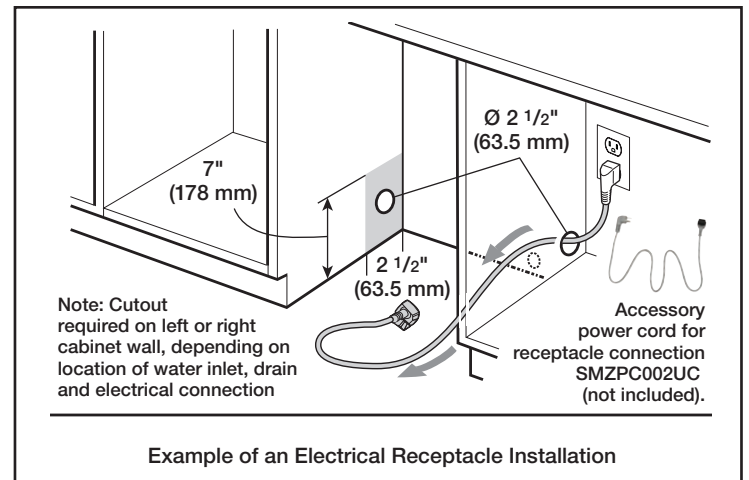
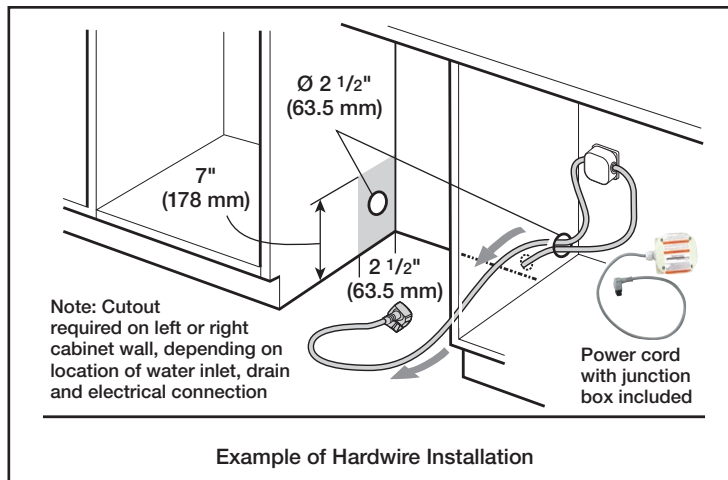
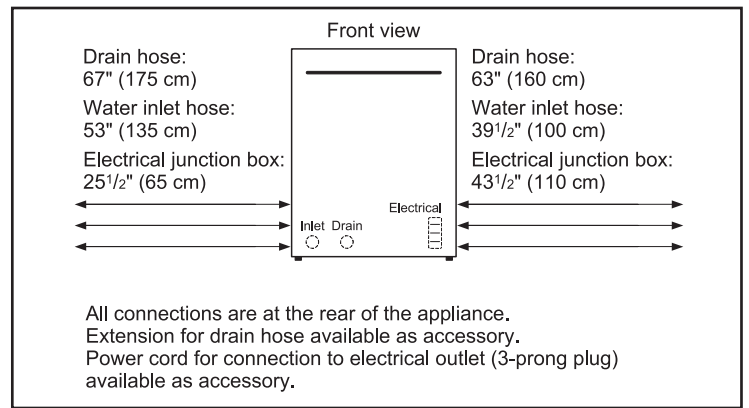
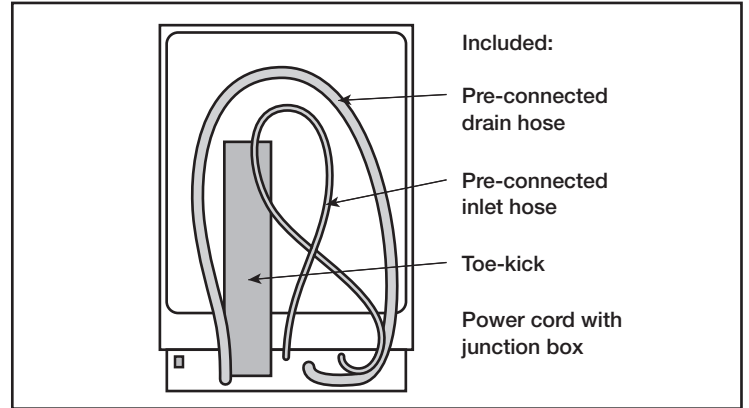
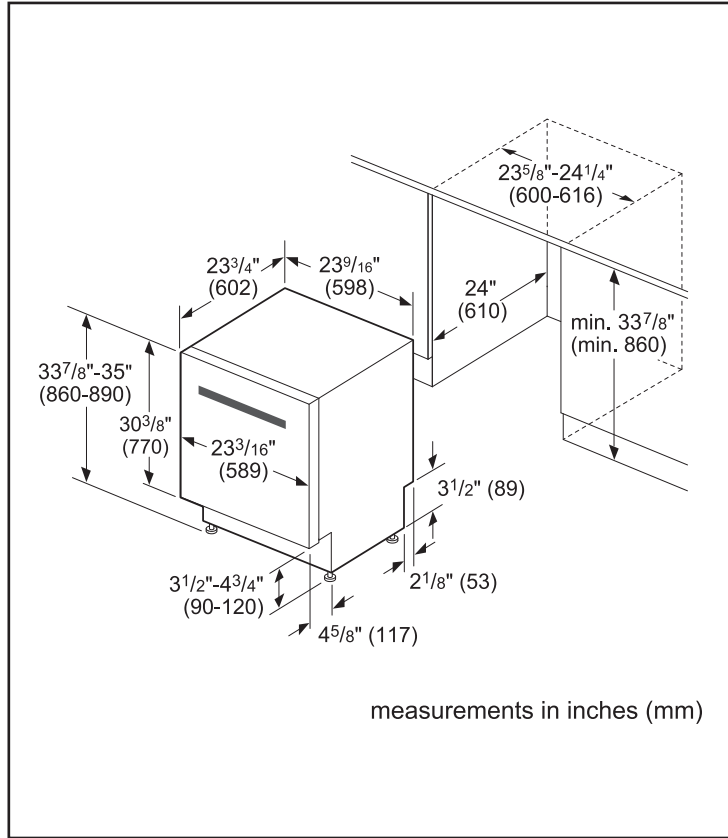

For help and assistance with Bosch accessories please call 1-800-944-2904 Mon-Fri 8am to 6pm EST

Notes: All height, width and depth dimensions are shown in inches. BSH reserves the absolute and unrestricted right to change product materials and specifications, at any time, without notice. Consult the product's installation instructions for final dimensional data and other details prior to making cutout. Applicable product warranty can be found in accompanying product literature or you may contact your account manager for further details.

Warranties: Bosch warrants that the Product is free from defects in materials and workmanship for a period of three hundred and sixty-five (365) days from the date of purchase. The foregoing timeline begins to run upon the date of purchase, and shall not be stalled, tolled, extended, or suspended, for any reason whatsoever. This Product is also warranted to be free from cosmetic defects in material and workmanship (such as scratches of stainless steel, paint/porcelain blemishes, chip, dents, or other damage to the finish) of the Product, for a period of thirty (30) days from the date of purchase or closing date for new construction. This cosmetic warranty excludes slight color variations due to inherent differences in painted and porcelain parts, as well as differences caused by kitchen lighting, product location, or other similar factors. This cosmetic warranty specifically excludes any display, floor, "As Is", or "B" stock appliances.

For more information on our entire line of products, go to www.bosch-home.ca or call 1-800-944-2904

© BSH Home Appliances Limited. All rights reserved. Bosch is a registered trademark of Robert Bosch GmbH.

24" Pocket Handle Dishwasher

800 Series – Stainless Steel SHP68T55UC



Installation Details

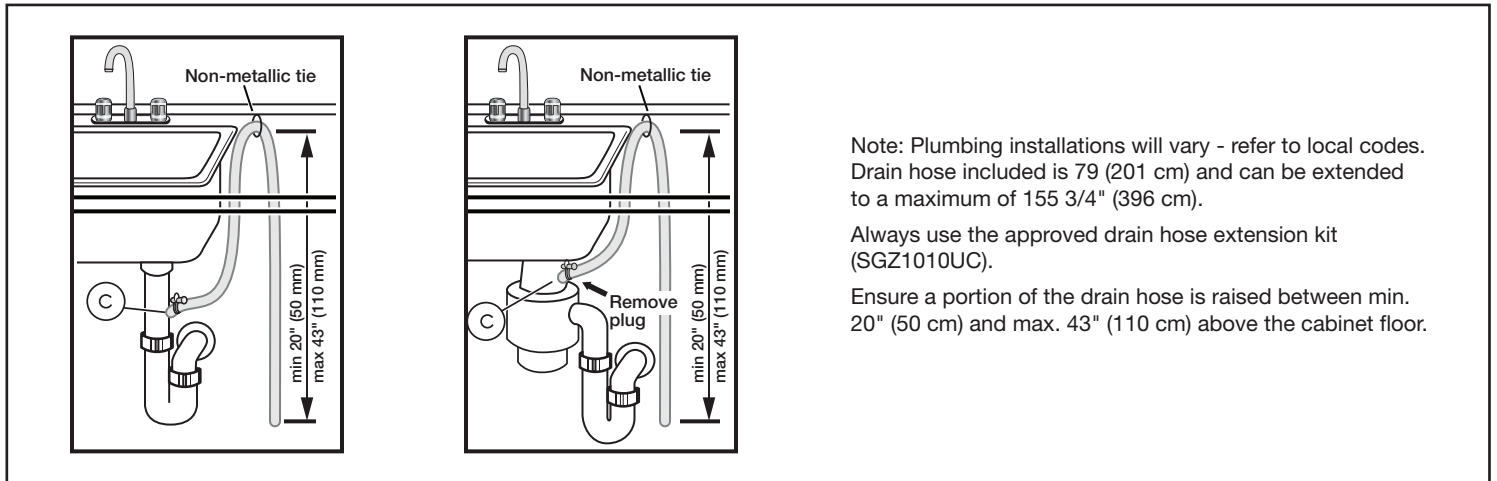

Note: Plumbing installations will vary - refer to local codes. Drain hose included is 79 (201 cm) and can be extended to a maximum of 155 3/4" (396 cm).

Always use the approved drain hose extension kit (SGZ1010UC).

Ensure a portion of the drain hose is raised between min. 20" (50 cm) and max. 43" (110 cm) above the cabinet floor.

For help and assistance with Bosch accessories please call 1-800-944-2904 Mon-Fri 8am to 6pm EST

Notes: All height, width and depth dimensions are shown in inches. BSH reserves the absolute and unrestricted right to change product materials and specifications, at any time, without notice. Consult the product's installation instructions for final dimensional data and other details prior to making cutout. Applicable product warranty can be found in accompanying product literature or you may contact your account manager for further details.

Warranties: Bosch warrants that the Product is free from defects in materials and workmanship for a period of three hundred and sixty-five (365) days from the date of purchase. The foregoing timeline begins to run upon the date of purchase, and shall not be stalled, tolled, extended, or suspended, for any reason whatsoever. This Product is also warranted to be free from cosmetic defects in material and workmanship (such as scratches of stainless steel, paint/porcelain blemishes, chip, dents, or other damage to the finish) of the Product, for a period of thirty (30) days from the date of purchase or closing date for new construction. This cosmetic warranty excludes slight color variations due to inherent differences in painted and porcelain parts, as well as differences caused by kitchen lighting, product location, or other similar factors. This cosmetic warranty specifically excludes any display, floor, "As Is", or "B" stock appliances.

For more information on our entire line of products, go to www.bosch-home.ca or call 1-800-944-2904

© BSH Home Appliances Limited. All rights reserved. Bosch is a registered trademark of Robert Bosch GmbH.

08/16