

24" Single Wall Oven

500 Series – Stainless Steel HBE5451UC



HBE5451UC
Stainless Steel

The 24" Bosch Wall Oven features Genuine European Convection and is Designed for Kitchens with a Smaller Footprint

Features & Benefits

A full-extension telescopic rack offers better access to the oven cavity.

Genuine European Convection for even baking results on multiple racks.

Beautifully designed knob controls that are easy to use.

The wall oven is designed to be installed flush with your cabinetry.

The DualClean™ system uses the cavity coating and heat to burn off most grease.

General Properties

Cooking modes	Bake, Broil Plus, Convection Bake, Convection Broil, Convection Broil Plus, Multi-Rack Genuine European Convection, Pie, Warm, Defrost, Frozen Foods
Cleaning type	DualClean™
Telescopic rack	1
Illumination type	Halogen
Interior lights	2

Oven Performance

Bake / broil element wattages	1,300 / 3,060 W
Convection element wattages	2,200 W

Technical Details

Watts (W)	3,300 W
Circuit breaker (A)	20 A
Volts (V)	240 / 208 V
Frequency (Hz)	60 Hz
Power cord length (in)	47 1/4"
Plug type	Fixed Connection, No Plug
Energy source	Electric

Dimensions & Weight

Overall appliance dimensions (HxWxD) (in)	23 5/16" x 23 1/2" x 22 1/2"
Required cutout size (HxWxD) (in)	21 15/16" – 23 1/16" x 21 15/16" x 22 1/16"
Oven cavity size (cu. ft.)	2.8
Overall oven interior dimensions (HxWxD) (in)	15 1/16" x 18 3/16" x 17 11/16"
Usable oven interior dimensions (HxWxD) (in)	11" x 17 1/4" x 16 1/4"
Net weight (lbs)	87 lbs

Accessories—Included

Included	1 Standard Rack, 1 Telescopic Rack
----------	------------------------------------



For help and assistance with Bosch accessories please call 1-800-944-2904 Mon-Fri 8am to 6pm EST

Notes: All height, width and depth dimensions are shown in inches. BSH reserves the absolute and unrestricted right to change product materials and specifications, at any time, without notice. Consult the product's installation instructions for final dimensional data and other details prior to making cutout. Applicable product warranty can be found in accompanying product literature or you may contact your account manager for further details.

Warranties: Bosch warrants that the Product is free from defects in materials and workmanship for a period of three hundred and sixty-five (365) days from the date of purchase. The foregoing timeline begins to run upon the date of purchase, and shall not be stalled, tolled, extended, or suspended, for any reason whatsoever. This Product is also warranted to be free from cosmetic defects in material and workmanship (such as scratches of stainless steel, paint/porcelain blemishes, chip, dents, or other damage) to the finish of the Product, for a period of thirty (30) days from the date of purchase or closing date for new construction. This cosmetic warranty excludes slight color variations due to inherent differences in painted and porcelain parts, as well as differences caused by kitchen lighting, product location, or other similar factors. This cosmetic warranty specifically excludes any display, floor, "As Is", or "B" stock appliances.

For more information on our entire line of products, go to www.bosch-home.ca or call 1-800-944-2904

© BSH Home Appliances Limited. All rights reserved. Bosch is a registered trademark of Robert Bosch GmbH.

09/15

24" Single Wall Oven

500 Series – Stainless Steel HBE5451UC



Installation Details

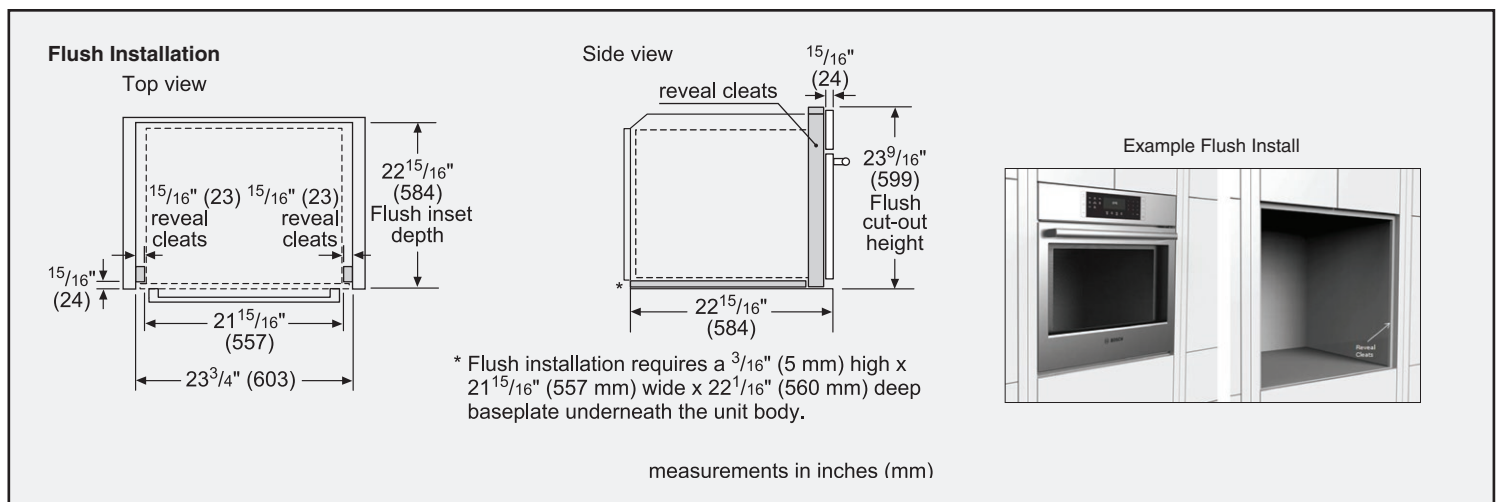
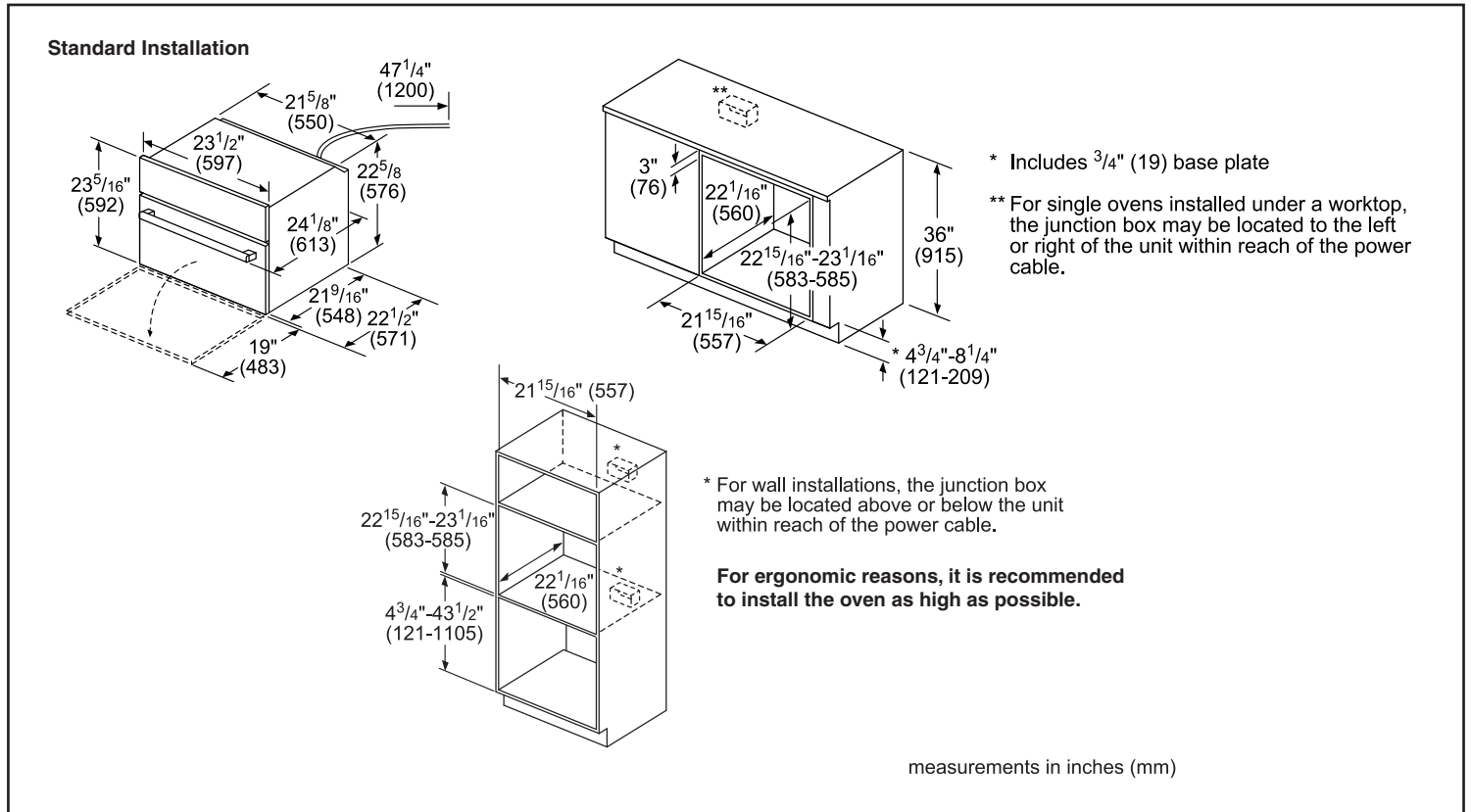

For help and assistance with Bosch accessories please call 1-800-944-2904 Mon-Fri 8am to 6pm EST

Notes: All height, width and depth dimensions are shown in inches. BSH reserves the absolute and unrestricted right to change product materials and specifications, at any time, without notice. Consult the product's installation instructions for final dimensional data and other details prior to making cutout. Applicable product warranty can be found in accompanying product literature or you may contact your account manager for further details.

Warranties: Bosch warrants that the Product is free from defects in materials and workmanship for a period of three hundred and sixty-five (365) days from the date of purchase. The foregoing timeline begins to run upon the date of purchase, and shall not be stalled, tolled, extended, or suspended, for any reason whatsoever. This Product is also warranted to be free from cosmetic defects in material and workmanship (such as scratches of stainless steel, paint/porcelain blemishes, chip, dents, or other damage) to the finish of the Product, for a period of thirty (30) days from the date of purchase or closing date for new construction. This cosmetic warranty excludes slight color variations due to inherent differences in painted and porcelain parts, as well as differences caused by kitchen lighting, product location, or other similar factors. This cosmetic warranty specifically excludes any display, floor, "As Is", or "B" stock appliances.

For more information on our entire line of products, go to www.bosch-home.ca or call 1-800-944-2904

© BSH Home Appliances Limited. All rights reserved. Bosch is a registered trademark of Robert Bosch GmbH.

09/15