

# 30" Gas Cooktop

500 Series – Stainless Steel NGM5055UC



NGM5055UC

**Bosch cooktops are engineered to perform, offering high heat burners for optimal cooking results.**

## Features & Benefits

Powerful 16,000 BTU burner for faster boiling time.

Heavy-duty metal knobs for a premium look and feel.

Automatic re-ignition burners.

## General Properties

Knob material	Metal
Sealed burners	Yes
Grate material	Cast iron

## Element Performance

Total BTU load (NG / LP)	41,500 / 38,200
Power of front left burner (NG / LP)	10,000 / 9,100
Power of back left burner (NG / LP)	10,000 / 9,100
Power of center burner (NG / LP)	N / A
Power of back right burner (NG / LP)	5,500 / 5,000
Power of front right burner (NG / LP)	16,000 / 15,000

## Technical Details

Watts	360 W
Circuit breaker	15 A
Volts	120 V
Frequency	60 Hz
Plug type	3 prong
Power cord length	60"
Energy source	Gas
Convertible to LP (kit required)	Yes

## Dimensions & Weight

Overall appliance dimensions (HxWxD)	3 13/16" x 31" x 21 1/4"
Required cutout size (HxWxD)	3 13/16" x 28 15/16" x 19 1/8"
Minimum distance from counter front	1 7/8"
Minimum distance from rear wall	3"
Net weight	37 lbs

## Accessories—Included

Included	LP conversion kit
----------	-------------------



**For help and assistance with Bosch accessories please call 1-800-944-2904 Mon-Fri 8am to 6pm EST**

Notes: All height, width and depth dimensions are shown in inches. BSH reserves the absolute and unrestricted right to change product materials and specifications, at any time, without notice. Consult the product's installation instructions for final dimensional data and other details prior to making cutout. Applicable product warranty can be found in accompanying product literature or you may contact your account manager for further details.

Warranties: Bosch warrants that the Product is free from defects in materials and workmanship for a period of three hundred and sixty-five (365) days from the date of purchase. The foregoing timeline begins to run upon the date of purchase, and shall not be stalled, tolled, extended, or suspended, for any reason whatsoever. This Product is also warranted to be free from cosmetic defects in material and workmanship (such as scratches of stainless steel, paint/porcelain blemishes, chip, dents, or other damage) to the finish of the Product, for a period of thirty (30) days from the date of purchase or closing date for new construction. This cosmetic warranty excludes slight color variations due to inherent differences in painted and porcelain parts, as well as differences caused by kitchen lighting, product location, or other similar factors. This cosmetic warranty specifically excludes any display, floor, "As Is", or "B" stock appliances.

**For more information on our entire line of products, go to [www.bosch-home.ca](http://www.bosch-home.ca) or call 1-800-944-2904**

© BSH Home Appliances Limited. All rights reserved. Bosch is a registered trademark of Robert Bosch GmbH.

09/15

# 30" Gas Cooktop

500 Series – Stainless Steel NGM5055UC



## Installation Details

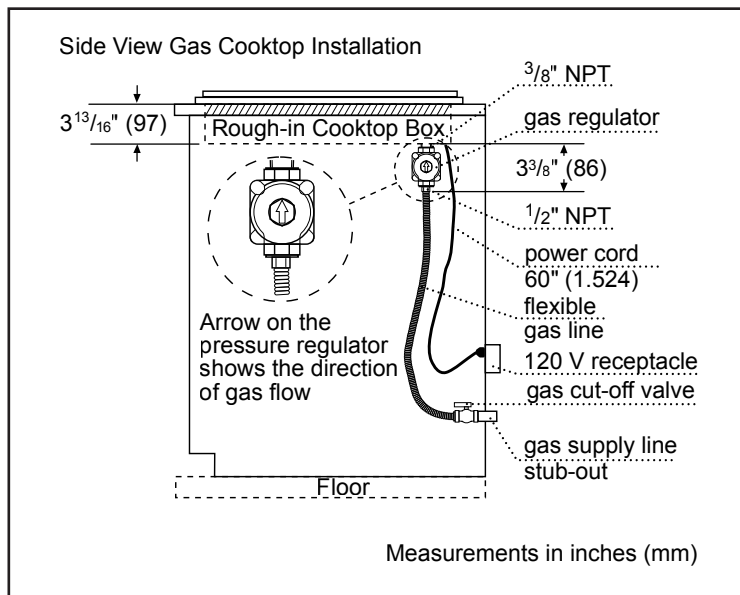
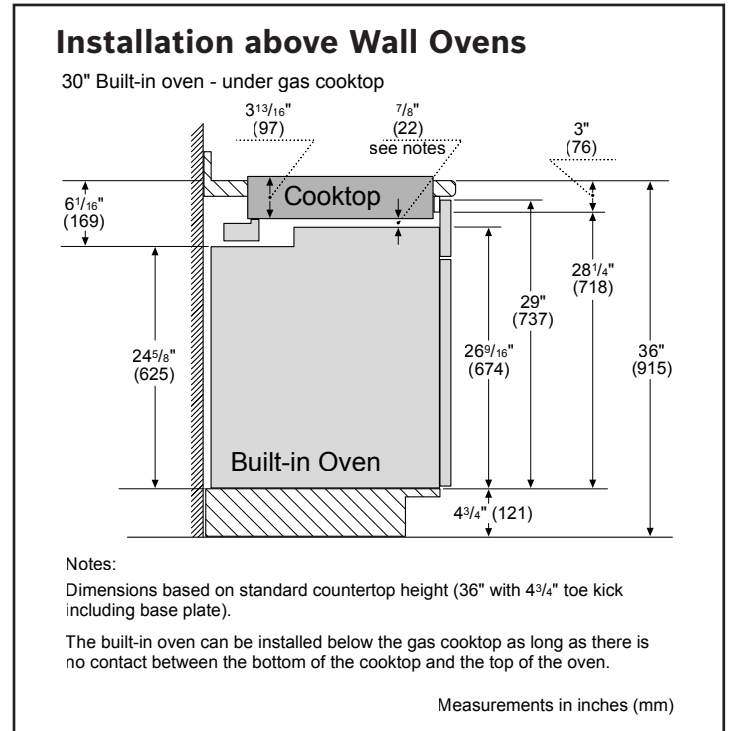
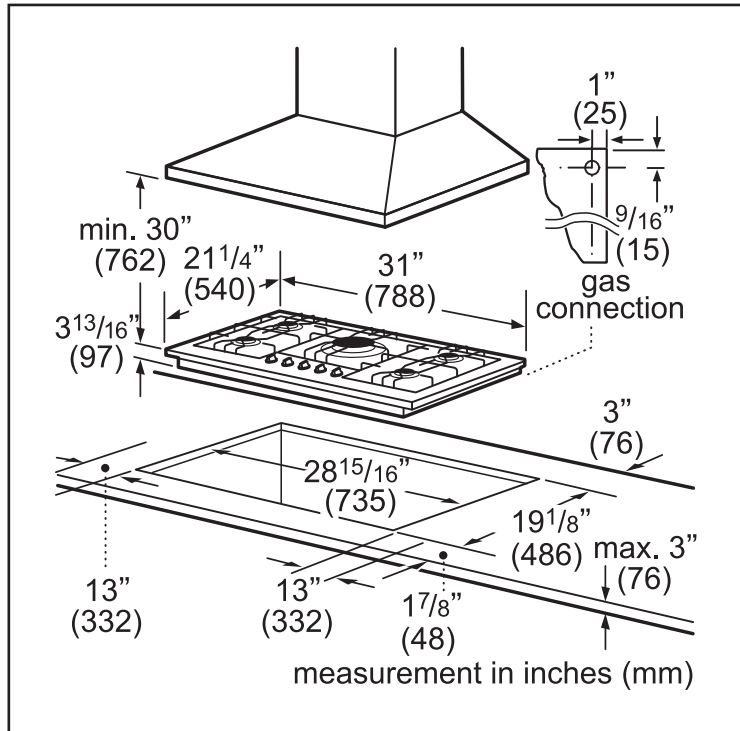

For help and assistance with Bosch accessories please call 1-800-944-2904 Mon-Fri 8am to 6pm EST

Notes: All height, width and depth dimensions are shown in inches. BSH reserves the absolute and unrestricted right to change product materials and specifications, at any time, without notice. Consult the product's installation instructions for final dimensional data and other details prior to making cutout. Applicable product warranty can be found in accompanying product literature or you may contact your account manager for further details.

Warranties: Bosch warrants that the Product is free from defects in materials and workmanship for a period of three hundred and sixty-five (365) days from the date of purchase. The foregoing timeline begins to run upon the date of purchase, and shall not be stalled, tolled, extended, or suspended, for any reason whatsoever. This Product is also warranted to be free from cosmetic defects in material and workmanship (such as scratches of stainless steel, paint/porcelain blemishes, chip, dents, or other damage) to the finish of the Product, for a period of thirty (30) days from the date of purchase or closing date for new construction. This cosmetic warranty excludes slight color variations due to inherent differences in painted and porcelain parts, as well as differences caused by kitchen lighting, product location, or other similar factors. This cosmetic warranty specifically excludes any display, floor, "As Is", or "B" stock appliances.

For more information on our entire line of products, go to [www.bosch-home.ca](http://www.bosch-home.ca) or call 1-800-944-2904

© BSH Home Appliances Limited. All rights reserved. Bosch is a registered trademark of Robert Bosch GmbH.

09/15