

30" Induction Cooktop

800 Series - Black with Stainless Steel Frame NIT8066SUC

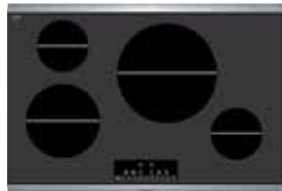

NIT8066SUC
Black with Stainless Steel Frame

Also available in:
Frameless NIT8066UC

The 800 Series induction cooktop is sleek in design, and features AutoChef® technology which maintains precise cooking temperatures.

Features & Benefits

AutoChef® maintains exact cooking temperature for consistent results.

A 11" heating element offers 3600W of power for quick results.

Induction cooktops offer faster cooking results than gas or electric.

Bosch-recommended AutoChef® pan included via mail-in redemption card.

SpeedBoost boils water 2x as fast as conventional electric cooktops.

PreciseSelect® offers 17 different direct cooking level settings.

Element Performance

Power of Front Left heating element	2,200 W
Power of Front Left heating element (in boost)	3,700 W
Power of Back Left heating element	1,400 W
Power of Back Left heating element (in boost)	1,800 W
Power of Back Right heating element	2,400 W
Power of Back Right heating element (in boost)	3,600 W
Power of Front Right heating element	1,400 W
Power of Front Right heating element (in boost)	1,800 W
Burners with booster	All

Element Size

Dimension of Front Left heating element	9"
Dimension of Back Left heating element	6"
Dimension of Back Right heating element	11"
Dimension of Front Right heating element	6"



Technical Details

Watts	7,200 W
Circuit breaker	30 A
Volts	208-240 V
Frequency	60 Hz
Plug type	No plug
Power cord length	37"
Energy source	Electric

Dimensions & Weight

Overall appliance dimensions (HxWxD)	5/16" +4 1/8" x 31" x 21 1/4"
Required cutout size (HxWxD)	4 1/8" x 28 3/4" x 19 7/8"
Minimum distance from counter front	2 1/4"
Minimum distance from rear wall	2"
Net weight	41 lbs

Accessories—Optional



HEZ390210
8" AutoChef® pan



HEZ390230
10" AutoChef® pan



For help and assistance with Bosch accessories please call 1-800-944-2904 Mon-Fri 8am to 6pm EST

Notes: All height, width and depth dimensions are shown in inches. Please refer to installation instructions prior to making cutout. BSH reserves the absolute and unrestricted right to change product materials and specifications, at any time, without notice. Consult the product's installation instructions for final dimensional data and other details. Applicable product warranty can be found in accompanying product literature or you may contact your account manager for further details.

Warranties: Bosch warrants that the Product is free from defects in materials and workmanship for a period of three hundred and sixty-five (365) days from the date of purchase. The foregoing timeline begins to run upon the date of purchase, and shall not be stalled, tolled, extended, or suspended, for any reason whatsoever. This Product is also warranted to be free from cosmetic defects in material and workmanship (such as scratches of stainless steel, paint/porcelain blemishes, chip, dents, or other damage to the finish of the Product) for a period of thirty (30) days from the date of purchase or closing date for new construction. This cosmetic warranty excludes slight colour variations due to inherent differences in painted and porcelain parts, as well as differences caused by kitchen lighting, product location, or other similar factors. This cosmetic warranty specifically excludes any display, floor, "As Is", or "B" stock appliances.

For more information on our entire line of products, go to www.bosch-home.ca or call 1-800-944-2904

© 2014 BSH Home Appliances Canada. All rights reserved. Bosch is a registered trademark of Robert Bosch GmbH.

30" Induction Cooktop

800 Series - Black with Stainless Steel Frame NIT8066SUC



Installation Details

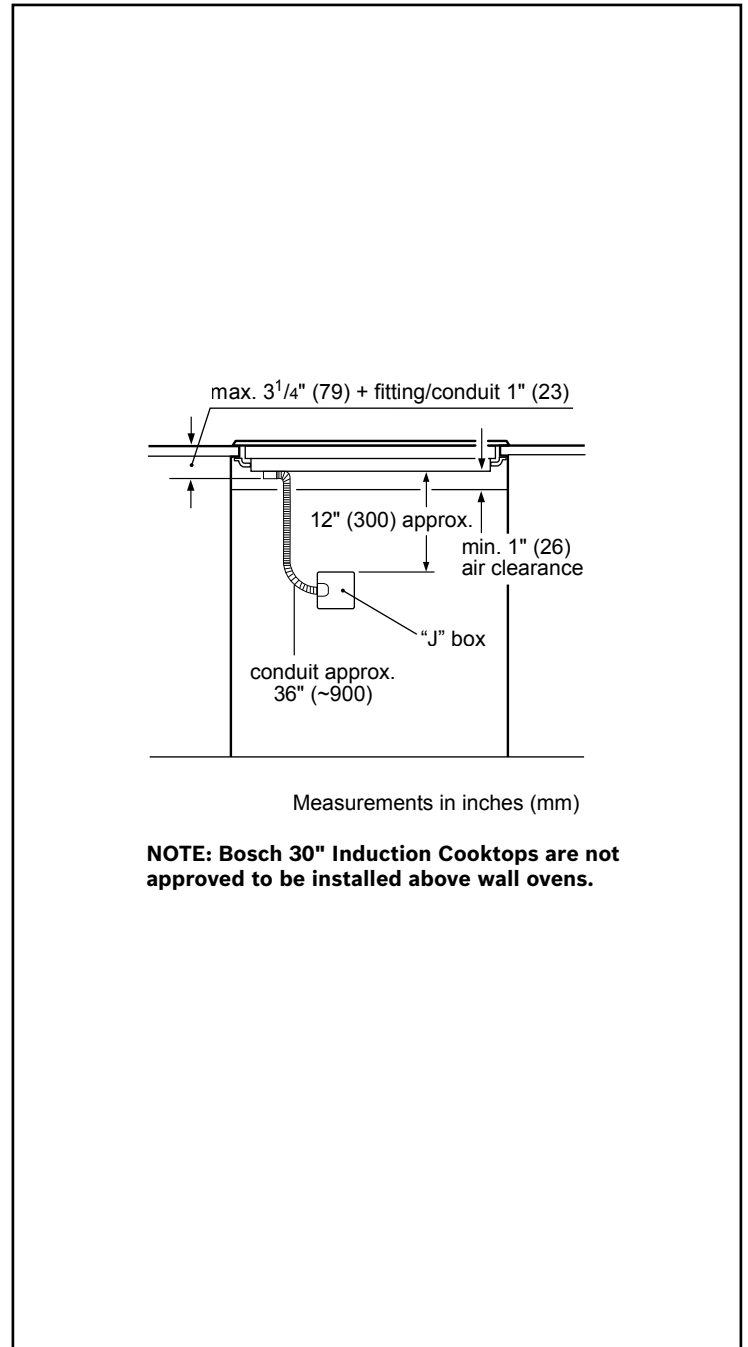
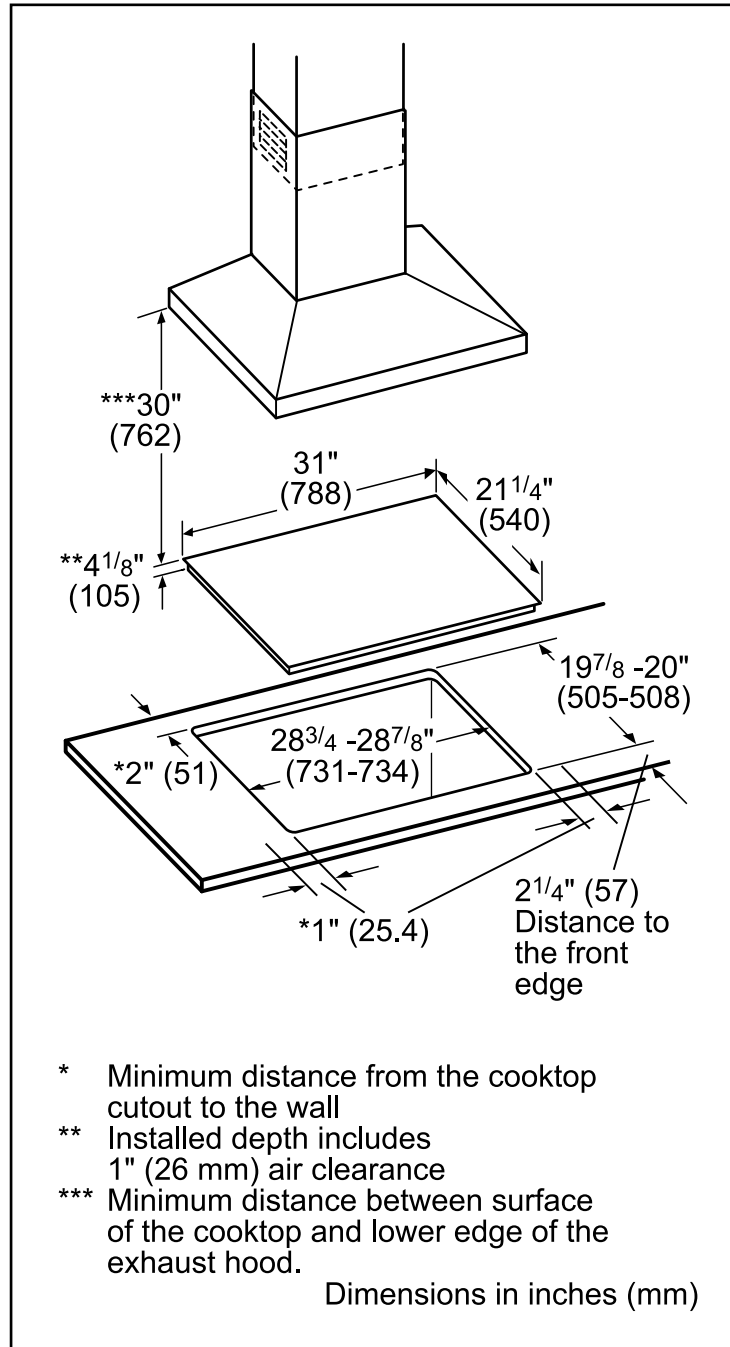

For help and assistance with Bosch accessories please call 1-800-944-2904 Mon-Fri 8am to 6pm EST

Notes: All height, width and depth dimensions are shown in inches. Please refer to installation instructions prior to making cutout. BSH reserves the absolute and unrestricted right to change product materials and specifications, at any time, without notice. Consult the product's installation instructions for final dimensional data and other details. Applicable product warranty can be found in accompanying product literature or you may contact your account manager for further details.

Warranties: Bosch warrants that the Product is free from defects in materials and workmanship for a period of three hundred and sixty-five (365) days from the date of purchase. The foregoing timeline begins to run upon the date of purchase, and shall not be stalled, tolled, extended, or suspended, for any reason whatsoever. This Product is also warranted to be free from cosmetic defects in material and workmanship (such as scratches of stainless steel, paint/porcelain blemishes, chip, dents, or other damage to the finish of the Product) for a period of thirty (30) days from the date of purchase or closing date for new construction. This cosmetic warranty excludes slight colour variations due to inherent differences in painted and porcelain parts, as well as differences caused by kitchen lighting, product location, or other similar factors. This cosmetic warranty specifically excludes any display, floor, "As Is", or "B" stock appliances.

For more information on our entire line of products, go to www.bosch-home.ca or call 1-800-944-2904

© 2014 BSH Home Appliances Canada. All rights reserved. Bosch is a registered trademark of Robert Bosch GmbH.