



WALL-MOUNT

ASPIRE SERIES

Dimensions

30"W x 20"D x 10"H
36"W x 20"D x 10"H

Models

EFG630SM Foglia 30" Stainless
EFG636SM Foglia 36" Stainless

Special features



halogen lamps



multi-function electronic controls with LCD display

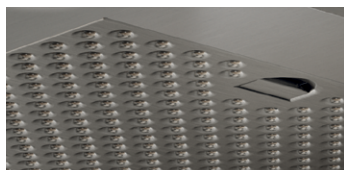

stainless steel micro hole filters



Foglia features a gently arched front that softens the units profile and provides an angled panel for easy access to the controls. Available in 30" & 36" widths, Foglia includes a powerful 600 CFM blower, halogen lighting with 2 light intensities, stainless steel microhole filters and multi-function electronic controls with LCD display that deliver convenience and safety.

Designed for standard ducted installation (for heights 7'1" to 9'1"), Foglia can also be installed as a recirculating system (for heights 7'5" to 9'6") using the Recirculating Kit, available as an accessory.

FEATURES

Size (in) & Type Finish	30" or 36" Wide Wall-Mount Chimney Stainless Steel
Controls	Multi-function electronic with LCD display
Illumination	2, 40 Watt Halogen Lamps, 2 Light Intensities (bulbs included)
Installation Type	Ducted or Recirculating Installation Recirculating Kit Sold Separately
Blower Type	600 CFM, 4-Speed Internal
Blower Performance	Speed 1 , 210 CFM, 1.9 Sones Speed 2 , 300 CFM, 4.5 Sones Speed 3 , 470 CFM, 7.9 Sones Speed 4 , 600 CFM, 9.3 Sones
Filter Type	Dishwasher-Safe, Stainless Steel Micro Hole (2 w/ 30", 3 w/ 36")
Telescopic Chimney Extension	For heights 7'1" - 9'1" (ducted) For heights 7'5" - 9'6" (recirculating)
Duct Transition	6" Round with Back Draft Damper (top)
Electrical	120V-60Hz 490 Watts at 4.1 Amps
Warranty	2 Year Parts & Labor, In-Home Service

ACCESSORIES

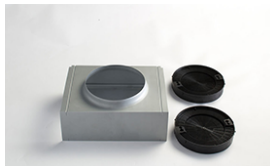

Optional Recirculating Kit for 30" and 36"

CODE: KIT02766
MODEL: EXXRCK09



Optional Long Chimney Extension Kit

Reaches 8'11" - 11'4" (ducted)
Reaches 9'3" - 11'8" (recirculating)

CODE: KIT02784
MODEL: EXXCEK08

LINE DRAWING

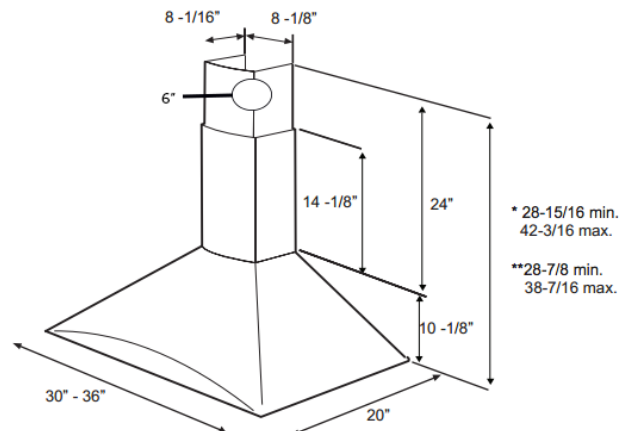

CONSUMABLE PARTS

Replacement Grease Filter (1)

CODE: GF04YB

Replacement Carbon Filter (1)

CODE: KIT02667

Replacement Light Bulb (1)

CODE: 2006BH

Consumable parts are sold in units of one (1). Order accordingly.

SPECIAL FEATURES



Elica CRS:

CFM Reduction System (CRS), is an exclusive feature to Elica hoods, which enables the installer to reduce the maximum blower CFM, to meet local code requirements.



Elica Heat Guard:

A safety feature that protects the hood and cabinetry from excessive heat, by sensing extreme temperatures (>158 degrees) and will automatically adjust the blower speed to HIGH. Blower speed will automatically adjust back once temperatures drop to a safe level.