

GRACE

HANGING



Ambient light



≥ 20"



≥ 28"

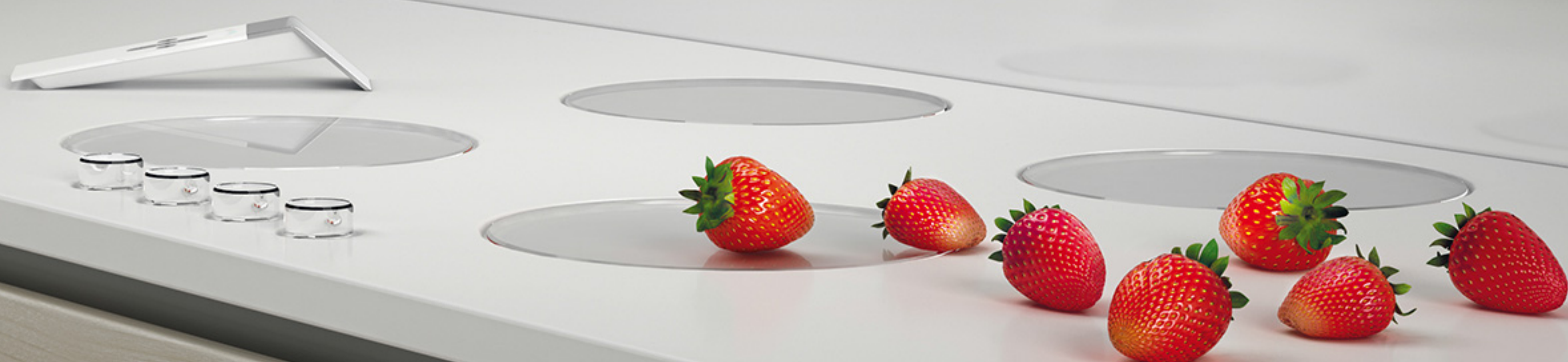

COLLECTION

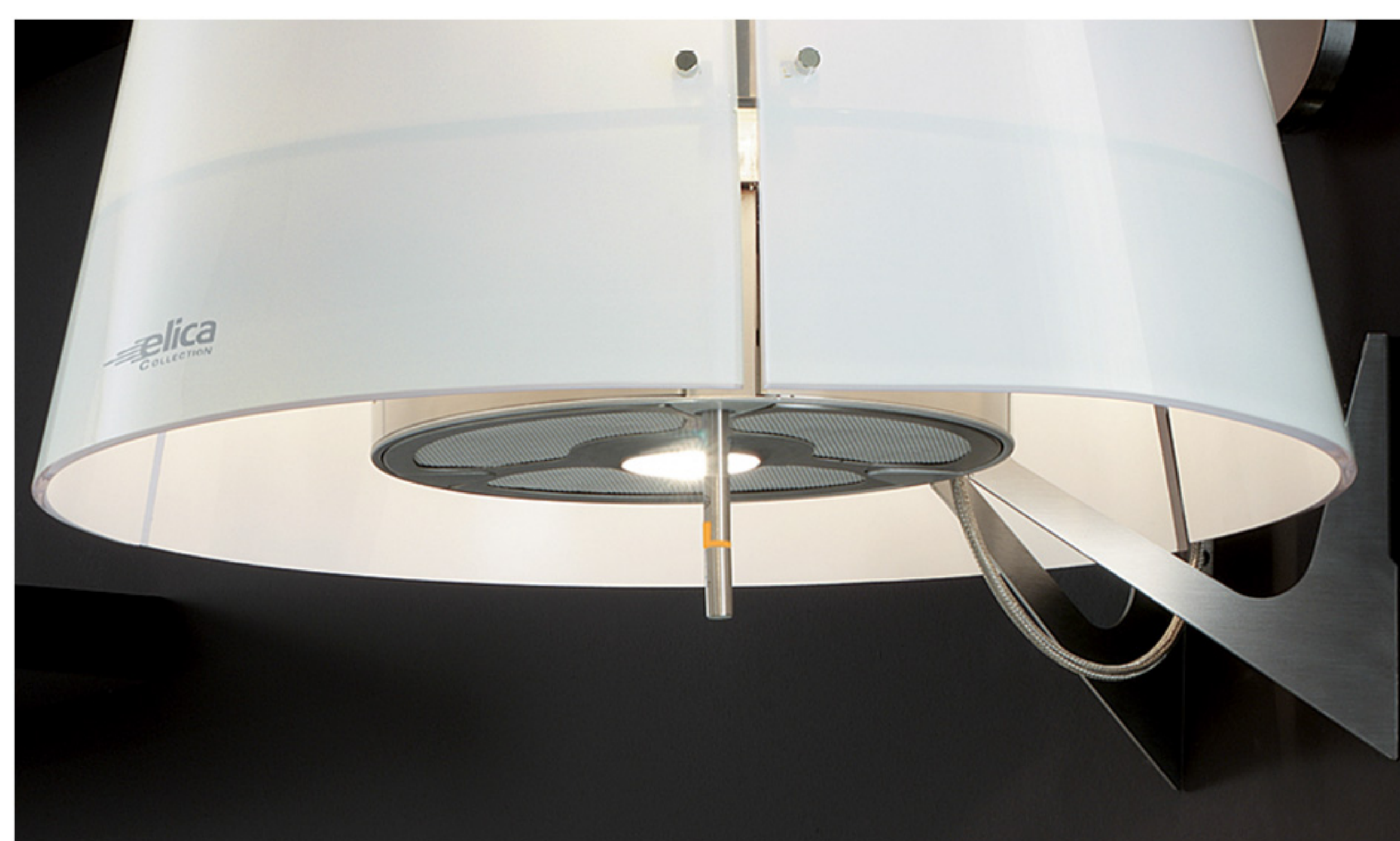

An everyday, intimate form that hides the true identity of the object that it is: bright enough to illuminate the words of a book, but intimately linked to the vital breath of the air.

(Wall installation with bracket possible)

evolution



Halogen Lamps & Incandescent Ambient Lamps



Magic Wand Controls



Aluminium Mesh Grease Filter & Long Life Carbon Filter

MODELS

EGR320BL Grace 20" Black
EGR320WH Grace 20" White

DIMENSIONS

(20 1/8" W x 20 1/8" D x 14 1/4" H)
(20 1/8" W x 20 1/8" D x 14 1/4" H)

FEATURES

Size (in) & Type Finish	20" Wide, Island/Wall Mounted Hood Stainless Steel & Opaline Glass	
Controls	Magic Wand	
Illumination	1, 20 Watt Halogen Flood Lamp, 1 Light Intensity 3, 40W Incandescent Ambient Lamps, 2 Light Intensities	(Bulbs Included) (Bulbs Included)
Installation Type	Recirculating Installation Only	
Blower Type	300 CFM, 4-Speed Internal	
Blower Performance	Speed 1, 100 CFM, 0.3 Sones Speed 2, 175 CFM, 2.1 Sones Speed 3, 250 CFM, 3.8 Sones Booster, 300 CFM, 4.1 Sones	
Filter Type	1, Dishwasher-Grease Aluminium Filter 1, Long Life Carbon Filter (Included)	
Standard Ceiling Height	Range 6' 10" - 10' 1"	
Electrical	120V - 60 Hz 320 Watt at 2.7 Amps	

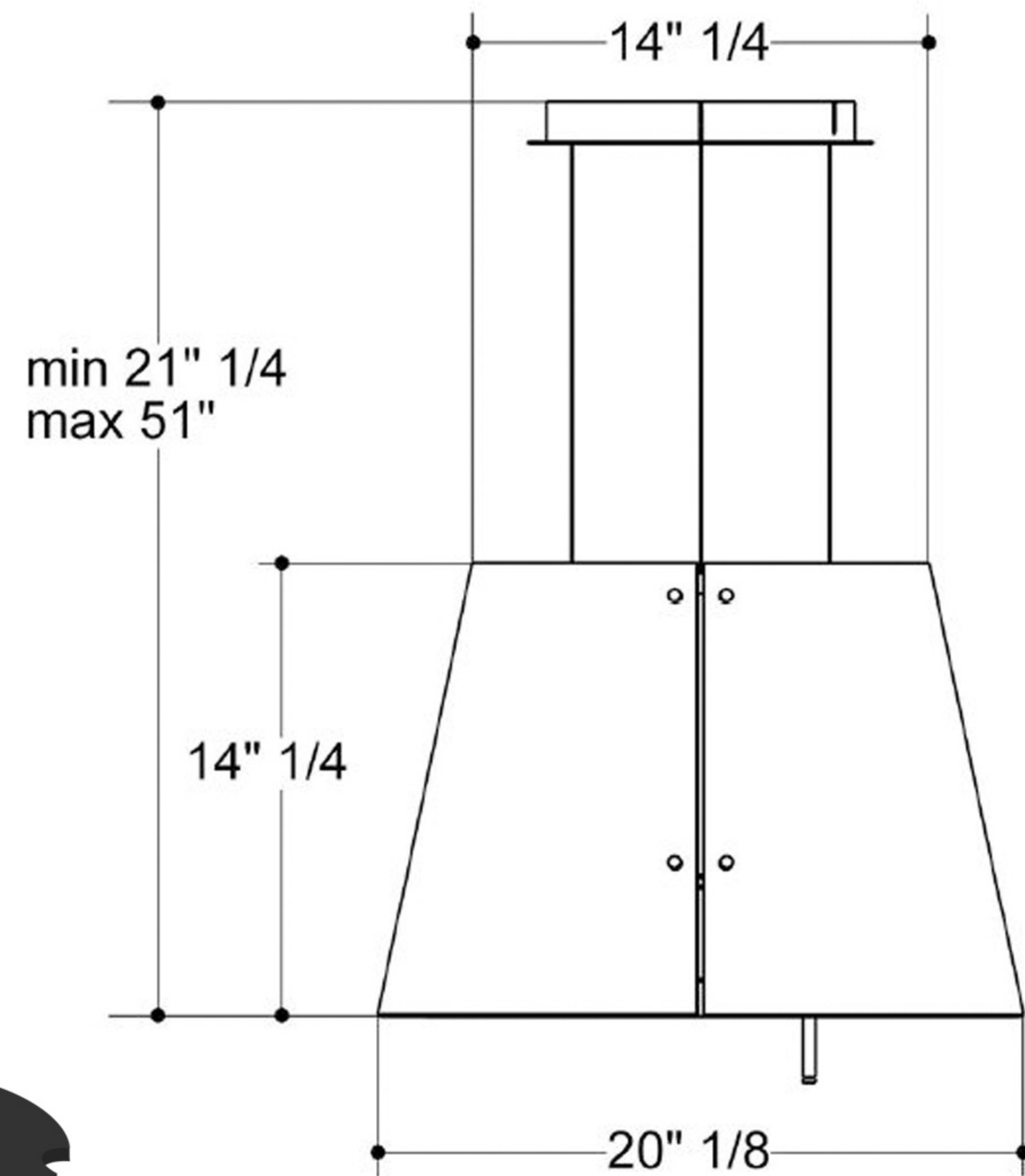

ACCESSORIES



Optional
Jet Remote
Control

CODE: KIT02183/1
MODEL: EXXRCDBL



Optional
Wall Mounting
Bracket Kit

CODE: KIT02663
MODEL: EXXWBK01



Optional
Ceiling Heights
Range 6' 10"- 23' 4"

CODE: KIT01921
MODEL: EXXEKSS



Optional
Long Life Carbon
Filter

CODE: F00433/1
MODEL: EXXRCKEV