

MICROWAVE OVEN TECH SHEET

CAUTION

Disconnect from Electrical Supply Before Servicing Unit

PRECAUTIONS TO BE OBSERVED BEFORE AND DURING SERVICING TO AVOID POSSIBLE EXPOSURE TO EXCESSIVE MICROWAVE ENERGY

- Do not operate or allow the oven to be operated with the door open.
- Make the following safety checks on all ovens to be serviced before activating the Magnetron or other microwave source, and make repairs as necessary.
 - Interlock operating.
 - Proper door closing.
 - Seal and sealing surfaces (Arcing, wear and other damage.)
 - Damage to or loosening of hinges and latch.
 - Evidence of dropping or abuse.
- Before turning on microwave power for any service test or inspection within the microwave generating compartments.

- check the magnetron. Waveguide or transmission line. And cavity for proper alignment, integrity and connection.
- Any defective or mis-adjusted components in the interlock, monitor, door seal, and microwave generation and transmission systems shall be repaired, replaced, or adjusted by producers. designed in this manual before the oven is released to the owner.
- A microwave leakage check to verify Compliance with the Federal performance Standard should be performed on each oven prior to release to the owner.
- Do not attempt to operate the oven if the door glass is broken.

Parts Layout

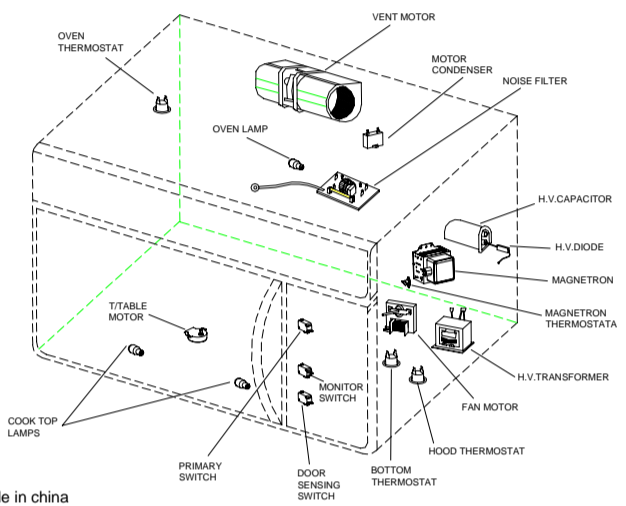

Made in china

Schematic Diagram

Warning : Power must be disconnected before servicing this appliance

MODEL NO. : FMV152K

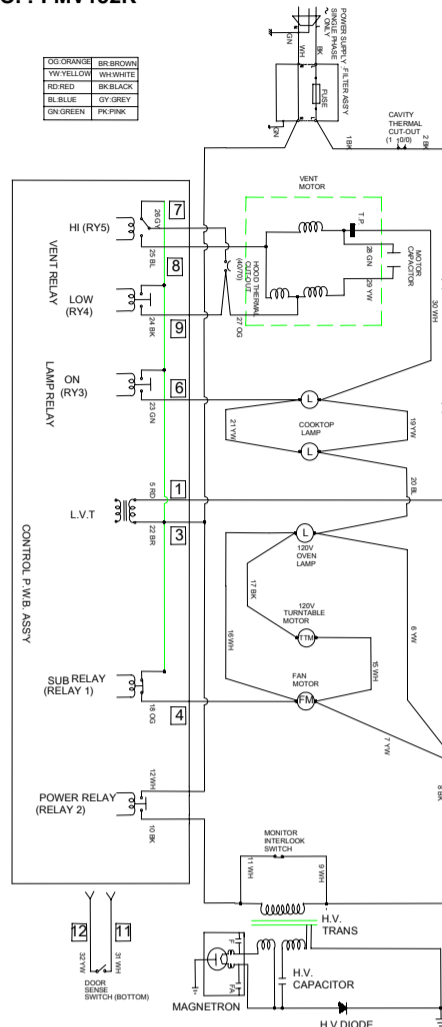

NOTE: Door is open

Wiring Diagram

Warning : Power must be disconnected before servicing this appliance

MODEL NO. : FMV152K

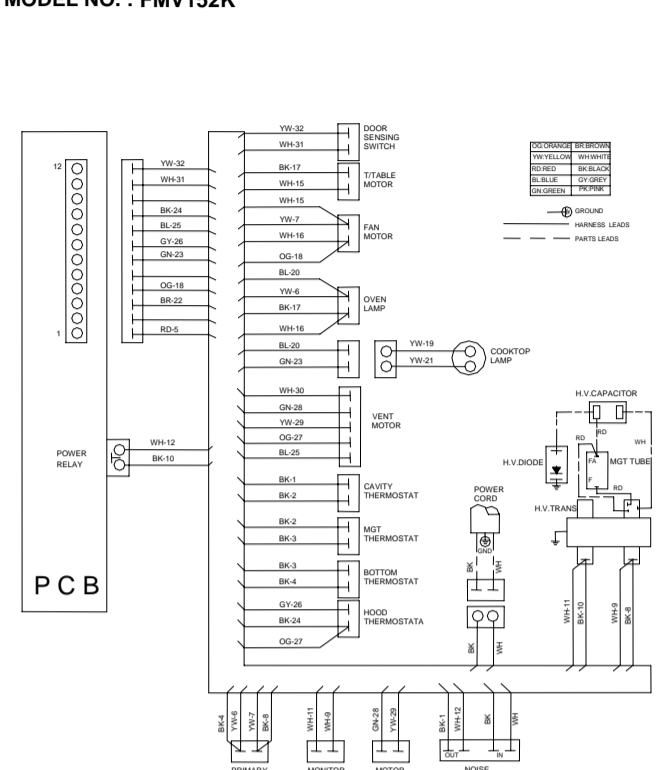

NOTE: For servicing replacement use 16GA, 105°C thermoplastic covered wire except for high voltage leads or as noted on special leads.

Switch Chart

SWITCH	CHECK BY	DOOR	DOOR CLOSE
Primary Interlock	Disconnect the wires at the Primary Interlock Switch. Check from the common terminal to the normally opened terminal.	-	+
Door sensing Interlock	Disconnect the wires at the sensing interlock Switch. Check from the common terminal and Normally closed terminal	-	+
Monitor Interlock	Disconnect the wires at the Monitor Switch. Check from the common terminal and Normally closed terminal .	+	-

(+) CONTINUITY
(-) NO CONTINUITY

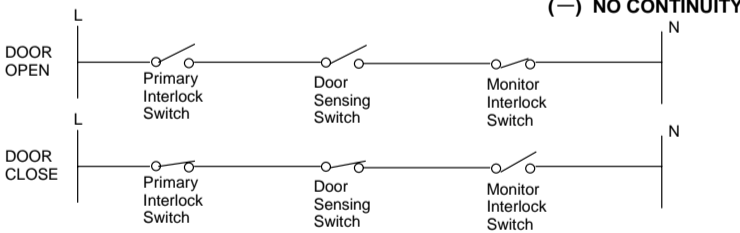

Note: These Diagrams are not intended to show a complete circuit, they represent the position of switches during "DOOR OPEN" and "DOOR CLOSED", (continuity checks only)

OUTPUT POWER OF MAGNETRON

CAUTION MICROWAVE RADIATION
PERSONNEL SHOULD NOT ALLOW EXPOSURE TO MICROWAVE RADIATION FROM MICROWAVE GENERATOR OTHER PARTS CONDUCTING MICROWAVE ENERGY.

The output power of the magnetron can be measured by performing a water temperature rise test. Equipment needed:

- * Two 1-liter cylindrical borosilicate glass vessel (Outside diameter 190 mm)
- * One glass thermometer with mercury column

NOTE: Check line voltage under load. Low voltage will lower the magnetron output.

- Fill the one liter glass vessel with water.
- Stir water in glass vessel with thermometer, and record glass vessel's temperature ("T1", 10± 1 °C).
- After moving the water into another glass vessel, place it in the center of the cooking tray. Set the oven to high power and operate for 47 seconds exactly. (3 seconds included as a holding time of magnetron oscillation)
- When heating is finished, stir the water again with the thermometer and measure the temperature ("T2").
- Subtract T1 from T2. This will give you the water temperature rise. (ΔT)
- The output power is obtained by the following formula;

$$\text{Output} = \frac{4.187 \times 1000 \times \Delta T + 0.55 \times M \times (T_2 - T_1)}{42}$$

45 : Heating Times (sec)
(3 seconds included as a holding time of magnetron oscillation.)
4.187 : Coefficient for water
1000 : Water (cc)
ΔT : Temperature Rise (T2-T1)
T0 : Room Temperature
Mc : Cylindrical borosilicate glass weight

- Normal temperature rise for this model is 9.9 °C to 10.3 °C at 'HIGH'.
NOTE 1: Variations or errors in the test procedure will cause a variance in the temperature rise. Additional power test should be made if temperature rise is marginal.
NOTE 2: Output power in watts is computed by multiplying the temperature rise (step 5) by a factor of 91 times the of centigrade temperature.

Component tests

WARNING

Personal injury/Product Hazard

- Disconnect the power supply cord from the outlet before removing the outer cabinet from the unit.
- Discharge the high voltage capacitor and remove the lead wires from the primary winding of the high voltage transformer before conducting any of the following tests.
- Conduct all operation tests with 1 liter of water in the oven.
- Conduct a microwave energy test after performing any test or repairs to the microwave.
- Check that all wire leads are in the correct position before operating the microwave oven.
- Grasp wire connectors when removing the wire leads from microwave parts.

Failure to follow these instructions may result in electrical shock or other Personal injury or in product damage.

High voltage components

Component	Test	Results
Transformer	<ol style="list-style-type: none"> Remove wire leads. Measure resistance (ohm meter scale: Rx1) <ul style="list-style-type: none"> Primary winding Secondary winding Filament winding Measure resistance (ohm meter scale: Rx1000) <ul style="list-style-type: none"> Primary winding to ground Filament winding to ground 	Approx. 0.334+2% ohm. Approx. 118.7+2% ohm. 0 ohm.. Normal: Infinite. Normal: Infinite.
Magnetron	<ol style="list-style-type: none"> Remove wire leads. Install the magnetron seal in the correct position. Check that the seal is in good condition. Measure resistance (ohm meter scale: Rx1) <ul style="list-style-type: none"> Filament winding Measure resistance (ohm meter scale: Rx1000) <ul style="list-style-type: none"> Filament to chassis 	Normal: Less than 1 ohm Normal: Infinite.
Capacitor	<ol style="list-style-type: none"> Remove wire leads. Measure resistance (ohm meter scale: Rx1000) <ul style="list-style-type: none"> Terminal to terminal Terminal to case 	Normal: Momentarily indicates several ohm, and then gradually returns to infinite. Normal: Infinite.
Diode	<ol style="list-style-type: none"> Measure continuity. Forward (ohm meter scale: Rx1000) Measure continuity. Reverse (ohm meter scale: Rx1000) 	Normal: Continuity. Abnormal: Infinite. Normal: Infinite. Abnormal: Continuity.
Ventilation Motor	<ol style="list-style-type: none"> Remove wire leads. Measure resistance (ohm meter scale: Rx1) 2 level: White and Blue wire 	Approximately 35.2 ohms

Other component tests

Components	Test	Results
T/Table Motor	<ol style="list-style-type: none"> Remove wire leads. Measure resistance. (ohm meter scale: Rx1000) 	Normal: Approximately: 3.3k ohms
Fan Motor	<ol style="list-style-type: none"> Remove wire leads. Measure resistance. (ohm meter scale: Rx1) 	Normal: Approximately: 97.4 ohms