

# CT9550EK

## GE Cafe™ Series 30 in. Built-In Double Convection Wall Oven

### DIMENSIONS AND INSTALLATION INFORMATION (IN INCHES)

**NOTE:** Cabinets installed adjacent to wall ovens must have an adhesion spec of at least a 194°F temperature rating.

Door handle protrudes 2-1/2" from door face. Cabinets and drawers on adjacent 45° and 90° walls should be placed to avoid interference with the handle.

Electric wall ovens are not approved for installation with a plug and receptacle. They must be hard wired in accordance with installation instructions.

**INSTALLATION INFORMATION:** Before installing, consult installation instructions packed with product for current dimensional data.

KW RATING	
240V	9.0
208V	6.8
BREAKER SIZE	
240V	40 Amps
208V	40 Amps

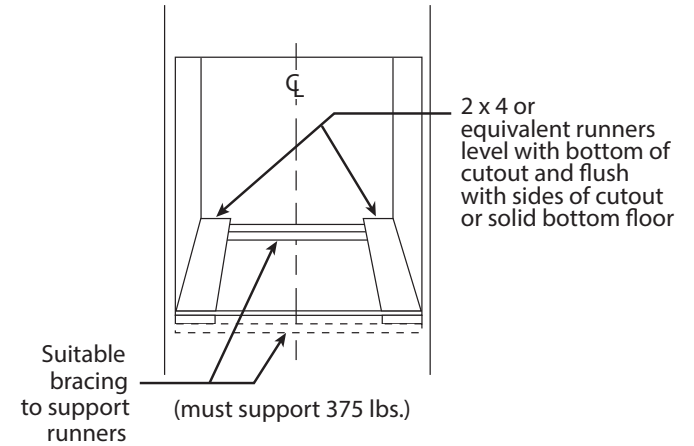
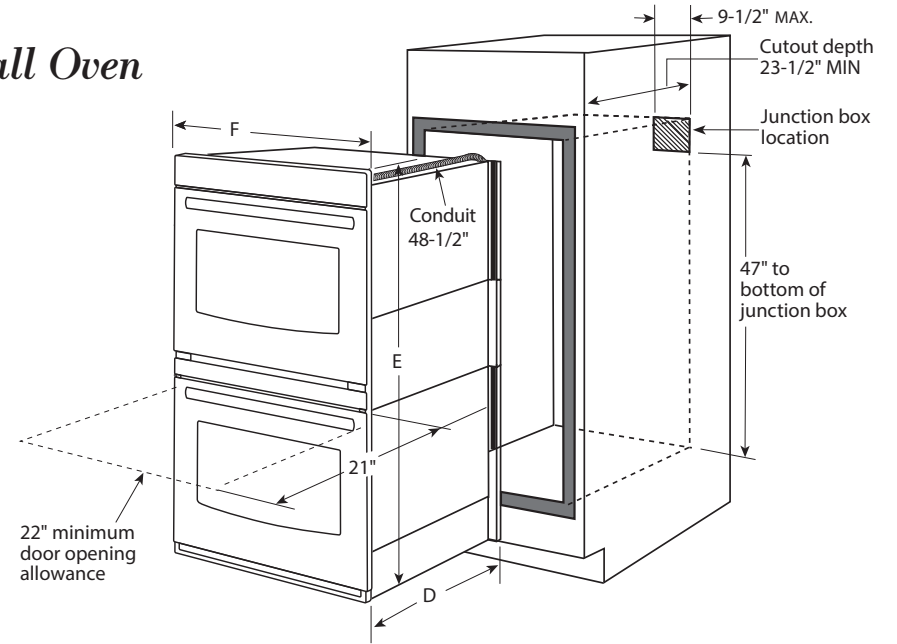
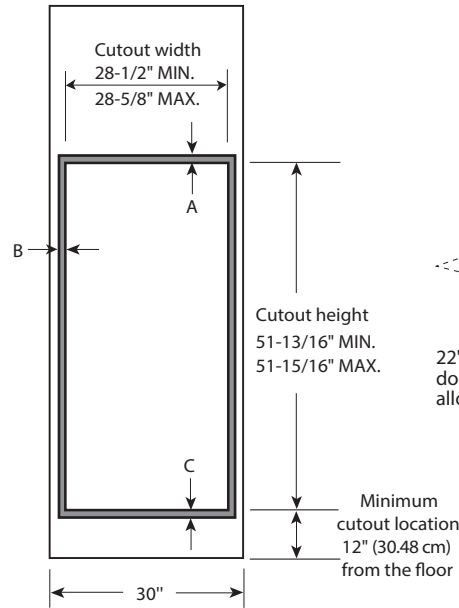

	CT9550
Cabinet	30"
A – Overlap of oven at top of cutout	1"
B – Overlap of oven over side of edges of cutout	3/4"
C – Overlap of oven at bottom of cutout	1-1/4"
Oven	
D – Install depth	23-1/2"
E – Overall height with trim	53"
F – Overall width	29-3/4"



For answers to your Monogram, GE Cafe™ Series, GE Profile™ Series or GE Appliances product questions, visit our website at [geappliances.com](http://geappliances.com) or call GE Answer Center® Service, 800.626.2000.



Listed by Underwriters Laboratories



# CT9550EK

## *GE Cafe™ Series 30 in. Built-In Double Convection Wall Oven*

### **FEATURES AND BENEFITS**

True European Convection with Direct Air (both ovens) - Bakes evenly as warm air blows from the top in and around bakeware

WiFi Connect – Wirelessly control oven functions from your smartphone

Notification lighting – Know the status of your oven functions with a quick glance

Ten-pass bake element – Even baking is assured with heat that covers more surface area

Ten-pass dual broil element – Large and small dishes brown evenly with two, full-coverage elements

Self-clean heavy-duty roller rack – Easily access items with a rack that glides smoothly

Progressive halogen oven lighting – See what you're baking with lights that slowly illuminate the oven

Self-clean with Steam Clean option (both ovens) – Clean your oven the way you want

Glass touch controls – Set temperatures quickly and clean with little effort

Double oven 10.0 cu. ft. total oven capacity (5.0 cu. ft. both ovens) – Large meals are easy with capacity that fits more at one time

Model CT9550EKDS – Black Slate

### **GUARANTEED FIT**

Replacing a similar wall oven from GE or another brand? GE wall ovens are guaranteed for an exact fit to make replacement easy

Visit [geappliances.com](http://geappliances.com) for more info

