

KitchenAid® Ice Maker

PRODUCT MODEL NUMBER

KUIC15NLX	KUIC15PLX	KUIS15NRX
KUIC15NRX	KUIC15PRX	

Electrical: A 115 Volt, 60 Hz., AC only, 15- or 20-amp electrical supply, properly grounded in accordance with the National Electrical Code and local codes and ordinances, is required.

It is recommended that a separate circuit, serving only your ice maker, be provided. Use a receptacle which cannot be turned off by a switch or pull chain.

IMPORTANT: If this product is connected to a GFCI (Ground Fault Circuit Interrupter) equipped outlet, nuisance tripping of the power supply may occur, resulting in loss of cooling. Food quality and flavor may be affected. If nuisance tripping has occurred, and if the condition of the food appears poor, dispose of it.

Water: A cold water supply with water pressure between 30 and 120 psi (207 and 827 kPa) is required to operate ice maker and water dispenser. If you have questions about your water pressure, call a licensed, qualified plumber.

Reverse Osmosis Water Supply:

- Reverse osmosis water filtration systems can be used only with ice maker installations that have a gravity drain. A reverse osmosis system is not recommended for ice makers that have a drain pump installed.
- The pressure of the water coming out of a reverse osmosis system going to the water inlet valve of the ice maker needs to be between 30 and 120 psi (207 and 827 kPa). If a reverse osmosis water filtration system is connected to your cold water supply, the water pressure to the reverse osmosis system needs to be a minimum of 40 to 60 psi (207 and 827 kPa).

Location:

- To ensure proper ventilation for your ice maker, the front side must be completely unobstructed. The ice maker may be closed-in on the top and three sides, but the installation should allow the ice maker to be pulled forward for servicing if necessary.
- Installation of the ice maker requires a cold water supply inlet of $\frac{1}{4}$ " (6.35 mm) OD soft copper tubing with a shutoff valve and either a gravity-drain system or condensate pump to carry the water to an existing drain.
- Choose a well ventilated area with temperatures above 55°F (13°C) and below 110°F (43°C). Best results are obtained between 70°F (21°C) and 90°F (32°C).

DRAIN REQUIREMENTS

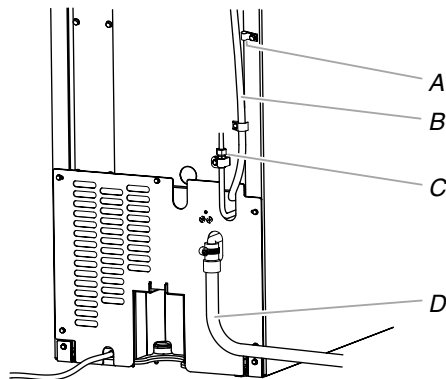

- A. Water supply tube clamp
- B. Vent hose (drain pump models only)
- C. Inlet water tube clamp and supply line connector
- D. Drain hose (drain pump models only)

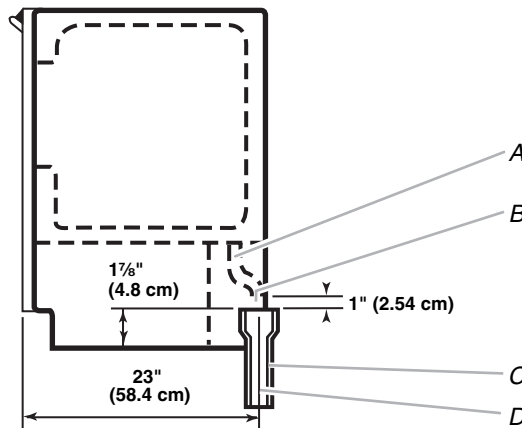

- A. Drain hose
- B. 1" (2.54 cm) air gap
- C. PVC drain reducer
- D. Center of drain should be 23" (58.4 cm) from front of door, with or without the $\frac{3}{4}$ " (1.91 cm) panel on the door. The drain should also be centered from left to right ($7\frac{1}{16}$ " [18.56 cm] from either side of the ice maker).

CABINET OPENING DIMENSIONS

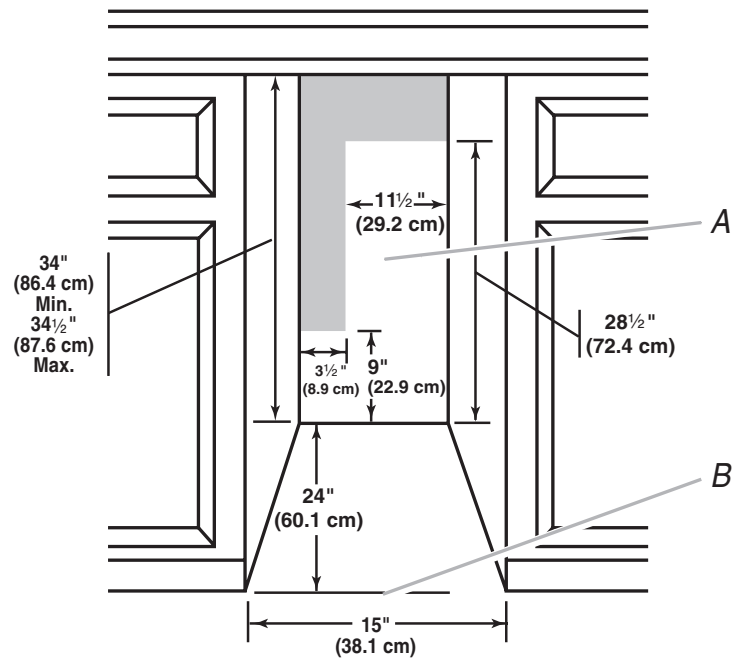

A. Recommended location for electrical and plumbing fixtures.

B. Floor level

- Be sure the power supply cord is not pinched between the ice maker and the cabinet.
- Be sure the water supply line is not pinched between the ice maker and the cabinet.
- Be sure the drain line (on some models) is not pinched between the ice maker and the cabinet.
- Choose a location where the floor is even. It is important for the ice maker to be level in order to work properly.

Drain: Either a gravity-drain system or condensate pump to carry water to an existing drain.

- Drain lines must have a minimum of $\frac{5}{8}$ " (15.88 mm) inside diameter.
- Drain lines must have a 1" drop per 48" (2.54 cm drop per 122 cm) of run or $\frac{1}{4}$ " drop per 12" (6.35 mm per 30.48 cm) of run and must not have low points where water can settle.
- The floor drains must be large enough to accommodate drainage from all drains.
- The ideal installation has a standpipe with a $1\frac{1}{2}$ " (3.81 cm) to 2" (5.08 cm) PVC drain reducer installed directly below the outlet of the drain tube as shown. You must maintain a 1" (2.54 cm) air gap between the drain hose and the standpipe.
- It may be desirable to insulate the drain line thoroughly up to the drain inlet.