

# NE595R1ABSR

5.9 cu. ft. Freestanding Flex Duo™ Range

## Features

- Flex Duo™ Technology – Large 5.9 cu. ft. Convection Oven Splits Into Two Cavities With a Removable Smart Divider.
- Dual Convection Oven
  - Top: Fan Convection
  - Bottom: True Convection
- Large Oven Capacity – 5.9 cu. ft.
  - Top: 2.7 cu. ft.
  - Bottom: 3.0 cu. ft.
- Five Electric Cooktop Elements
  - Two Dual Burners (12"/9" and 9"/6")
  - Two Single Burners (6")
  - Warming Center
- SteamQuick™ (20 min. Oven Cleaning) and Self Clean
- Four Preset Menu Cook Options

## Convenience

- Hot Surface Indicator Light
- Auto Oven Light (2)
- Proofing
- Sabbath Mode
- Kitchen Timer
- Delay Start
- Child Safety Lock
- 2 Chrome Oven Racks
- Hidden Bake Element



Flex Duo™ Oven



Dual Convection Oven

## Available Colors:



Stainless Steel  
(shown)



White



Black

## Signature Features

### FLEX DUO™ OVEN

- The spacious 5.9 cu. ft. oven splits into two ovens with the smart divider to cook at two different temperatures at the same time.
- Two temperature controls cook dishes at different temperatures.
- No noticeable transfer of aroma.

### DUAL CONVECTION OVEN

- Convection fan in both chambers cooks food faster and more evenly.

### ADJUSTABLE COOKTOP ELEMENTS

- Easy to maintain ceramic cooktop with the flexibility of five elements, including two dual burners.



Ranked **"Highest in Customer Satisfaction with Ranges, Cooktops and Ovens"** by J.D. Power and Associates.

**SAMSUNG**

# NE595R1ABSR

5.9 cu. ft. Freestanding Flex Duo™ Electric Range

## Installing Your Range

\*30" minimum clearance between the top of the cooking surface and the bottom of an unprotected wood or metal cabinet; or 24" minimum when the bottom of the wood or metal cabinet is protected by not less than 1/4" flame retardant millboard covered with not less than no.28 MSG sheet steel, 0.015" stainless steel, 0.024" aluminum or 0.020" copper.

\*\*15" minimum between the countertop and the adjacent cabinet bottom.

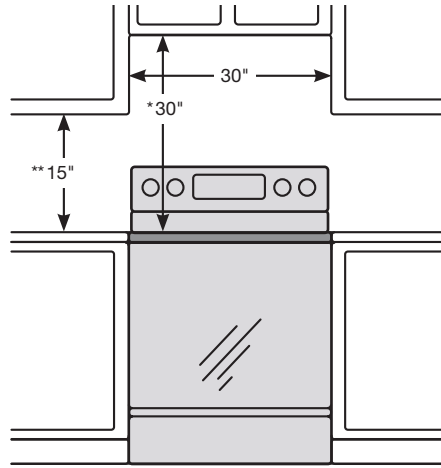

**IMPORTANT:** To eliminate the risk of burns or fire caused by reaching over heated surface units, cabinet storage space located above the surface units should be avoided. If cabinet storage is to be provided, the risk can be reduced by installing a range hood that projects horizontally a minimum of 5" beyond the bottom of the cabinets.

## Dimensions

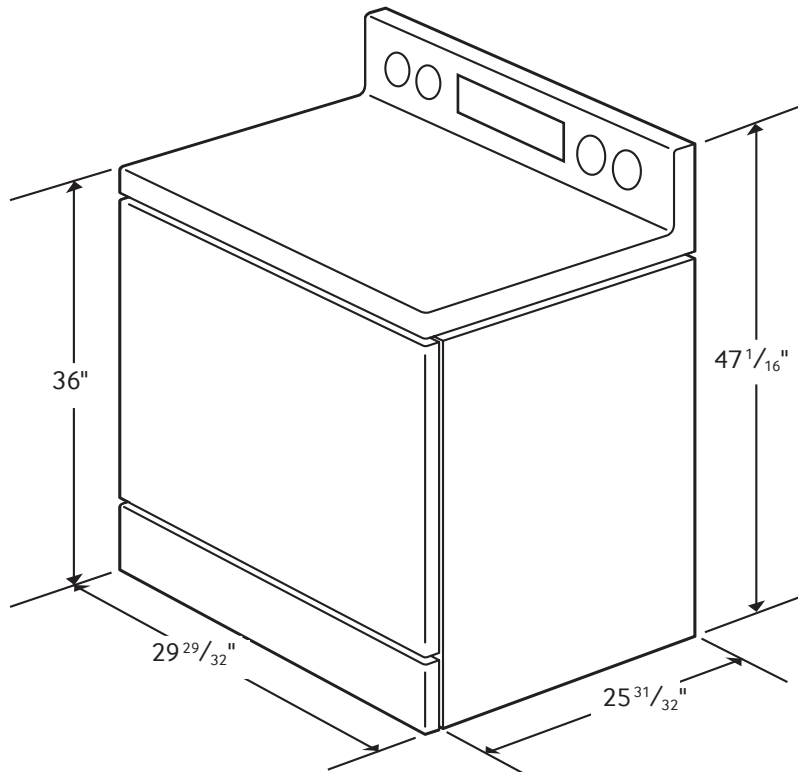

## Power Consumption

40 Amps

## Power Source

240 V/60 Hz

## Induction/Radiant Ceramic Cooktop

- Right Front: Radiant 9/12", 3.0 KW – Fast Boil
- Left Front: Radiant 6/9", 3.0 KW – Fast Boil
- Right Rear: Radiant 6", 1.2 KW
- Left Rear: Radiant 6", 1.2 KW
- Center Rear: Warming Center, 100 W

## Oven

- Hidden Bake Element: 3000 W
- Convection Bake: 150°F - 550°F
- Convection Roast: 150°F - 550°F
- Broil Element: 3800 W
- Convection Element/Heater: 1300 W
- Broil: Low/Hi (375°F - 450°F)
- Proofing
- Sabbath Mode

## Warranty

One (1) Year All Parts and Labor

Five (5) Years Electric Cooktop

## Product Dimensions & Weight (WxHxD)

Actual Oven Dimensions:

25" x 20<sup>25</sup>/<sub>32</sub>" x 18<sup>15</sup>/<sub>16</sub>"

Outside Net Dimensions:

29<sup>29</sup>/<sub>32</sub>" x 47<sup>1</sup>/<sub>16</sub>" x 25<sup>31</sup>/<sub>32</sub>"

Weight: 166 lbs.

## Shipping Dimensions & Weight (WxHxD)

Dimensions:

32<sup>7</sup>/<sub>8</sub>" x 50<sup>13</sup>/<sub>32</sub>" x 30<sup>1</sup>/<sub>8</sub>"

Weight: 199 lbs.

Color	Model #	UPC Code
Stainless Steel	NE595R1ABSR	036725570719

**SAMSUNG**

Samsung received the highest numerical score for ranges, cooktops and ovens in the proprietary J.D. Power 2014 Kitchen Appliance Study™. Study based on 15,380 total responses measuring 17 ranges, cooktops and oven brands and measures opinions of consumers about their new appliance purchased in the past 24 months. Proprietary study results are based on experiences and perceptions of consumers surveyed in January-March 2014. Your experiences may vary. Visit [jdpower.com](http://jdpower.com).

Actual color may vary. Design, specifications, and color availability are subject to change without notice. Non-metric weights and measurements are approximate.

©2014 Samsung Electronics America, Inc. 85 Challenger Road, Ridgefield Park, NJ 07660. Tel: 800-SAMSUNG. [samsung.com](http://samsung.com). Samsung is a registered trademark of Samsung Electronics Co. Ltd.