

NE59M4320SS

SAMSUNG

Samsung Freestanding Electric Range

5.9 cu. ft. Capacity



Signature Features

Stainless Steel Cooktop with Die-Cast Knobs

- Premium look and larger cooking space for greater flexibility to use multiple pot and pan sizes.

Fan Convection

- Fan Convection circulates air for faster, more even cooking.

5.9 cu. ft. Capacity

- Cook multiple dishes at once or accommodate larger items for the holidays.

Available Colors



Stainless Steel (shown)



Black Stainless Steel



White



Black



Stainless Steel Cooktop



Powerful/Flexible Cooktop

Features

- Flexible Cooktop – Five Electric Elements
 - Two Dual Elements (6"/9", 9"/12")
 - Two Single Elements (6")
 - One Warming Center (7")
- Warming Center
- Hidden Bake Element
- 3 Preset Easy Cook Options
- Storage Drawer
- Wide View Window

Convenience

- Auto Oven Light
- Kitchen Timer
- Sabbath Mode
- Proofing
- Delay Start
- Child Safety Lock
- Self & Steam Clean
- 2 Chrome Racks

NE59M4320SS

SAMSUNG

Samsung Freestanding Electric Range

5.9 cu. ft. Capacity

Installation Specifications

*30" minimum clearance between the top of the cooking surface and the bottom of an unprotected wood or metal cabinet; or 24" minimum when the bottom of the wood or metal cabinet is protected by not less than 1/4" flame-retardant millboard covered with not less than no. 28 MSG sheet steel, 0.015" stainless steel, 0.024" aluminum or 0.020" copper.

**15" minimum between the countertop and the adjacent cabinet bottom.

IMPORTANT: To eliminate the risk of burns or fire caused by reaching over heated surface units, cabinet storage space located above the surface units should be avoided. If cabinet storage is to be provided, the risk can be reduced by installing a range hood that projects horizontally a minimum of 5" beyond the bottom of the cabinets.

A: Required Cabinet Opening is 30"

B: Acceptable Electrical Outlet Space

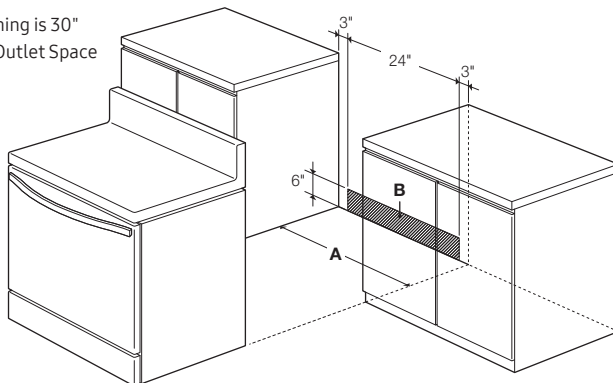
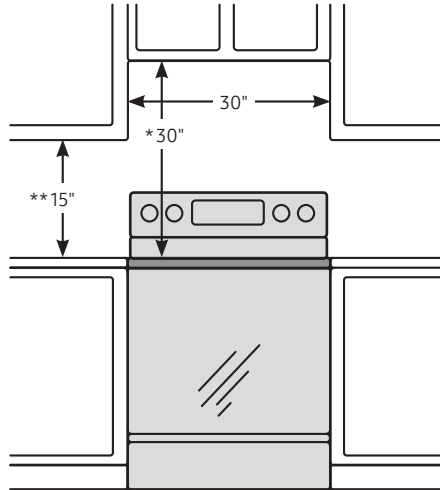

Dimensions

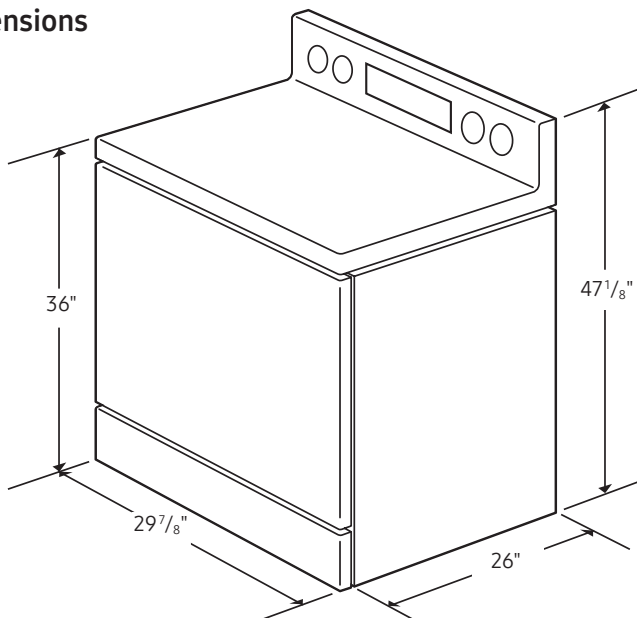

Radiant Ceramic Cooktop

- Right Front: 9"/12" Dual Element, 3000W
- Left Front: 6"/9" Dual Element, 3000W
- Right Rear: 6" Element, 1200W
- Left Rear: 6" Element, 1200W
- Center Rear: 7" Warming Center

Oven

- Capacity: 5.9 cu. ft.
- Hidden Bake Element
- Bake: 175°F–550°F
- Convection Bake: 175°F–550°F
- Convection Roast: 175°F–550°F
- Broil: Low/High

Storage Drawer

Capacity: 1.4 cu. ft.

Warranty

One (1) Year All Parts and Labor
Five (5) Years Electric Cooktop

Product Dimensions & Weight (WxHxD)

Actual Oven Dimensions:

25" x 19 1/4" x 21 1/4"

Outside Net Dimensions: 29 7/8" x 47 1/8" x 26"

Weight: 159.2 lbs. (Stainless Steel)

141.3 (Black Stainless Model)

140.7 (White and Black Model)

Shipping Dimensions & Weight (WxHxD)

Dimensions: 33" x 50 1/2" x 30 1/8"

Weight: 183.4 lbs. (Stainless Steel)

166.0 (Black Stainless Model)

164.9 (White and Black Model)

Color

Stainless Steel

Black Stainless Steel

White

Black

Model

NE59M4320SS

NE59M4320SG

NE59M4320SW

NE59M4320SB

UPC Code

887276197234

887276197227

887276197210

887276197258