

SERIES | 6
610

LCD TV

quick start guide

imagine the possibilities

Thank you for purchasing this Samsung product.
To receive more complete service, please register
your product at

www.samsung.com/global/register



Connections

⚠ Caution

- When connecting an external device, match the colour of the connection terminal to the cable.
- The product colour and shape may vary depending on the model.
- Each Cable Box/Satellite receiver (Set-Top Box) has a different back panel configuration.
- Whenever you connect an external device to your TV, make sure that power on the unit is turned off.

CONNECTING A CABLE BOX/SATELLITE RECEIVER (SET-TOP BOX) VIA HDMI

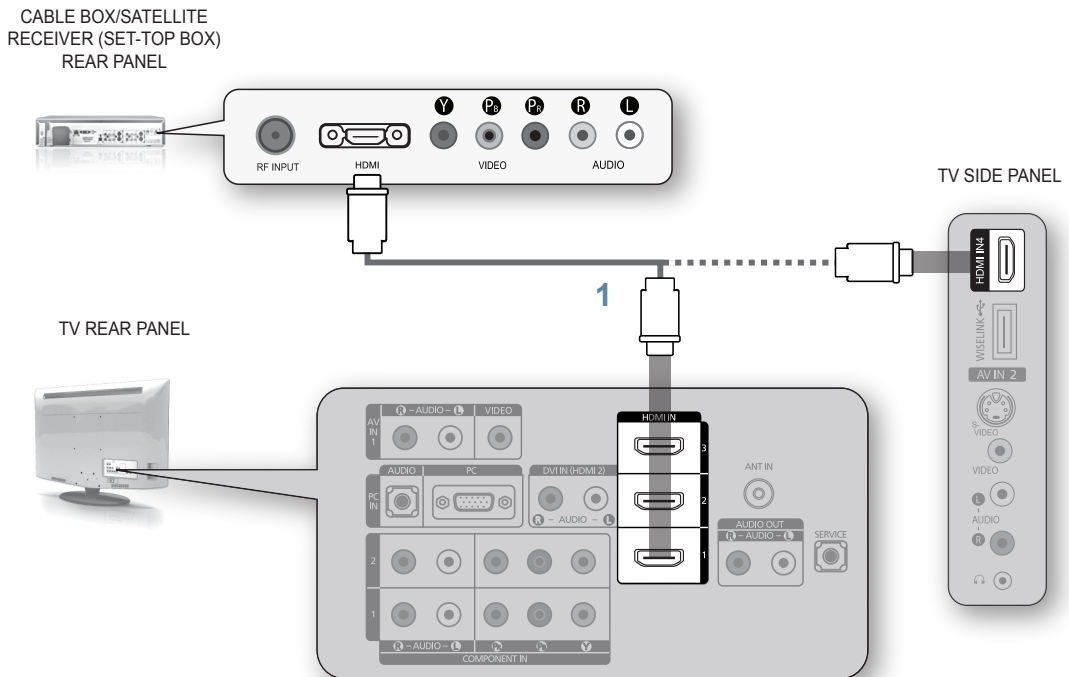

1. Connect an HDMI Cable (Not supplied) between the **HDMI IN (1, 2, 3 or 4)** jack on the TV and the HDMI jack on the Cable Box/Satellite receiver (Set-Top Box).

☑ No additional Audio connection is needed for an HDMI to HDMI connection.

CONNECTING A CABLE BOX/SATELLITE RECEIVER (SET-TOP BOX) VIA DVI

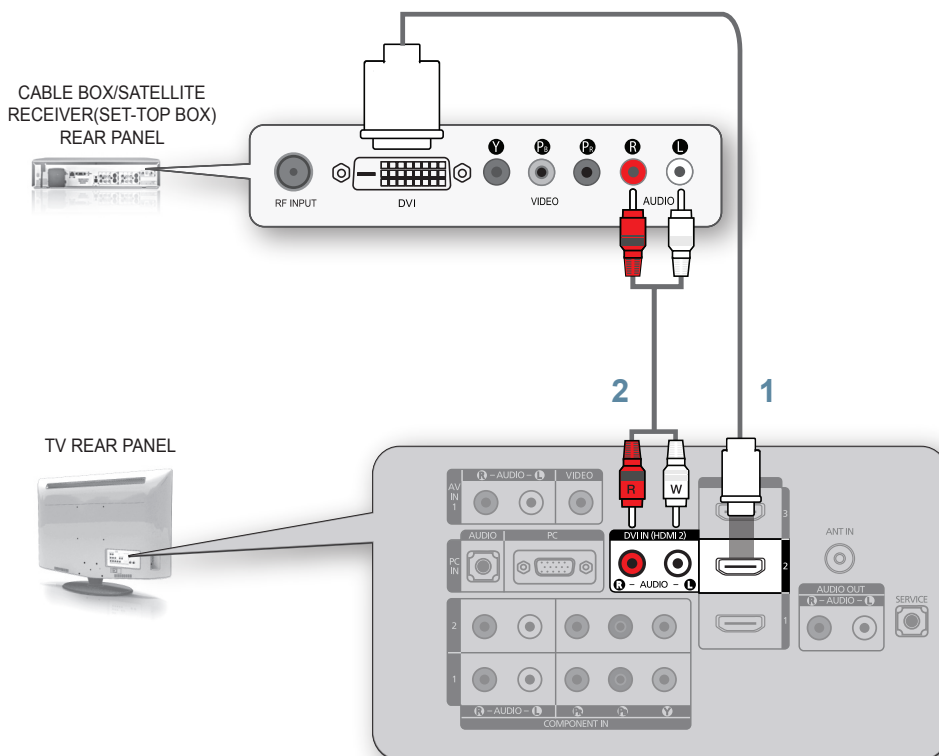

1. Connect an HDMI Cable(Not supplied) between the **HDMI IN 2** jack on the TV and the HDMI jack on the Cable Box/Satellite receiver (Set-Top Box).
 2. Connect Audio Cables(Not supplied) between the **DVI IN (HDMI 2) [R-AUDIO-L]** jack on the TV and the Cable Box/Satellite receiver (Set-Top Box).
- 📝 When using an HDMI/DVI cable(Not supplied) connection, you must use the **HDMI IN2** jack.

CONNECTING A CABLE BOX/SATELLITE RECEIVER (SET-TOP BOX) VIA COMPONENT CABLES

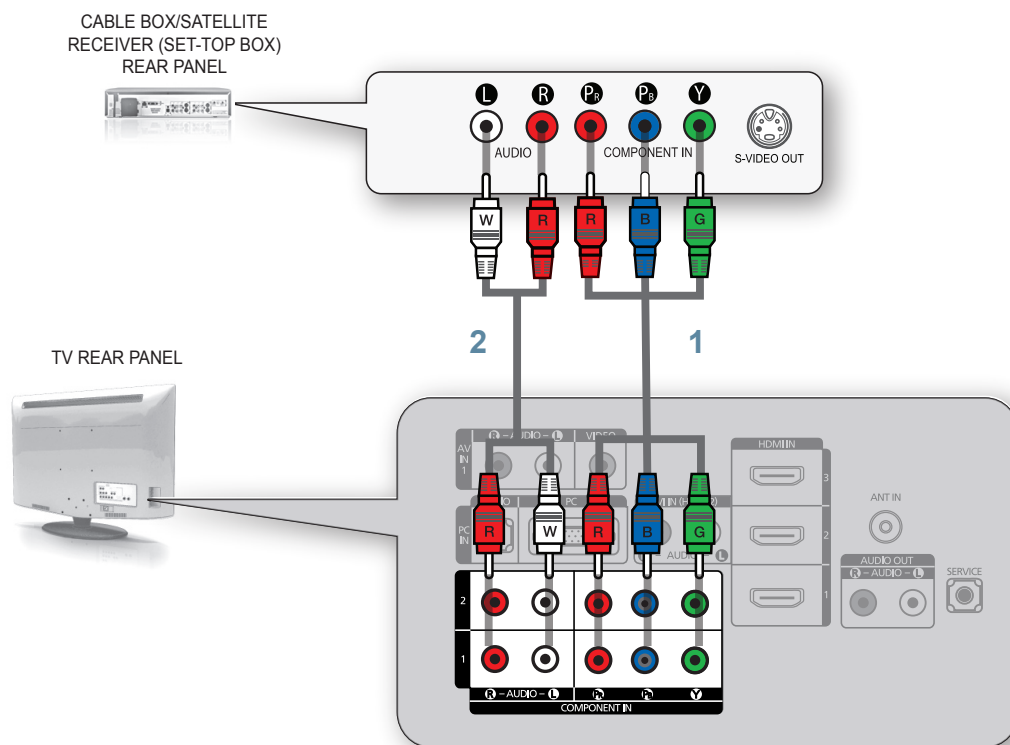

1. Connect a Component Cable(Not supplied) between the **COMPONENT IN (1 or 2) [Y, Pb, Pr]** jacks on the TV and the **COMPONENT** jacks on the Cable Box/Satellite receiver (Set-Top Box).
2. Connect Audio Cables(Not supplied) between the **COMPONENT IN (1 or 2) [R-AUDIO-L]** jacks on the TV and the **AUDIO OUT** jacks on the Cable Box/Satellite receiver (Set-Top Box).

Memorizing the Channels

Your TV can memorize and store all of the available channels for both “off-air” (Air) and “Cable” channels. After the available channels are memorized, use the **CH** or **CH** button to scan through the channels. This eliminates the need to change channels by entering the channel digits. There are three steps for memorizing channels: selecting a broadcast source, memorizing the channels (automatic) and adding or deleting channels (Channel Manager).

Selecting the Video Signal-source

Before your television can begin memorizing the available channels, you must specify the type of signal source that is connected to the TV (i.e. an Air or a Cable system).

1. Press the **MENU** button to display the menu.
Press the **▲** or **▼** button to select "Channel", then press the **ENTER** button.
2. Press the **ENTER** button.
Repeatedly press the **▲** or **▼** button to cycle through these choices: "Air", "STD", "HRC", or "IRC" (all cable TV)
Press the **ENTER** button to select.
 - STD, HRC and IRC identify various types of cable TV systems.
Contact your local cable company to identify the type of cable system that exists in your particular area.
At this point, the signal source has been selected

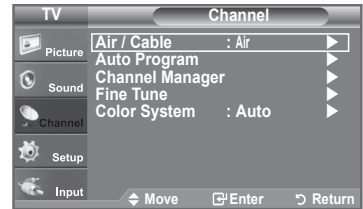

Storing Channels in Memory (Automatic Method)

1. First, select the correct signal source (Air, STD, HRC, or IRC).
2. Press the **▲** or **▼** button to select “Auto Program”, then press the **ENTER** button.
3. Press the **ENTER** button to select “Start”.
The TV will begin memorizing all of the available channels.
 - The TV automatically cycles through all of the available channels and stores them in memory. This takes about one to two minutes. Press the **ENTER** button at any time to interrupt the memorization process and return to the “Channel” menu.
4. After all the available channels are stored, the “Channel” menu reappears. Press the **EXIT** button to exit.
 - To stop the search before it has finished, press the **ENTER** button with “Stop” selected.

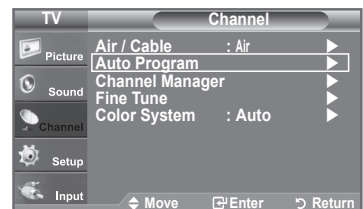

Troubleshooting

My TV is out of order.	Why?	Try this.
TV HD is displayed, but the visual quality is not good.	<ul style="list-style-type: none">• The visual quality may be degraded when the broadcasting stations convert the analog signal to digital. (Although you are watching digital broadcasting, the video source is analog.)	<ul style="list-style-type: none">• Check the transmitting signal of the corresponding cable TV network or broadcasting station.
The picture on the TV screen is broken intermittently (a mosaic or distorted).	<ul style="list-style-type: none">• This may occur when the broadcast signal received by the TV is too weak or unstable.	<ul style="list-style-type: none">• Check the transmitting signal of the corresponding cable TV network or broadcasting station.• If you are using a publically shared antenna, check the signal by asking your apartment manager.
I cannot control the TV using the remote control.	<ul style="list-style-type: none">• When the battery is flat.• When it is not in TV mode.• When the remote control malfunctions temporarily.	<ul style="list-style-type: none">• Replace the battery and then retry.• Press the TV button on the remote control to select TV mode.
A strange sound is generated by the TV.	<ul style="list-style-type: none">• Sound may be generated by the temporary swelling and shrinking of the plastics in the TV due to temperature and humidity changes.• Temporary electronic oscillation sounds may be generated due to the characteristics of the TV	<ul style="list-style-type: none">• Some noise can be heard due to the characteristics of the product.



Contact SAMSUNG WORLDWIDE

If you have any questions or comments relating to Samsung products, please contact the SAMSUNG customer care center.

COUNTRY	Customer Care Center ☎	Web Site
ARGENTINE	0800-333-3733	www.samsung.com/ar
BRAZIL	0800-124-421 4004-0000	www.samsung.com
CHILE	800-SAMSUNG(726-7864)	www.samsung.com/cl
COLOMBIA	01-8000112112	www.samsung.com.co
COSTA RICA	0-800-507-7267	www.samsung.com/latin
ECUADOR	1-800-10-7267	www.samsung.com/latin
EL SALVADOR	800-6225	www.samsung.com/latin
GUATEMALA	1-800-299-0013	www.samsung.com/latin
HONDURAS	800-7919267	-
JAMAICA	1-800-234-7267	www.samsung.com/latin
PANAMA	800-7267	www.samsung.com/latin
PUERTO RICO	1-800-682-3180	www.samsung.com/latin
REP. DOMINICA	1-800-751-2676	www.samsung.com/latin
NICARAGUA	00-1800-5077267	-
MEXICO	01-800-SAMSUNG(726-7864)	www.samsung.com
TRINIDAD & TOBAGO	1-800-SAMSUNG(726-7864)	www.samsung.com/latin
VENEZUELA	0-800-100-5303	www.samsung.com/latin

IMPORTADO POR:

AV. PRESIDENTE MASARIK #111 INT701

COL. CHAPULTEPEC MORALES C.P.11570

DELEGACION MIGUEL HIDALGO MEXICO. DISTRITO FEDERAL

Tel: 01-55-5747-5100 / 01-800-726-7864