

### **Performance**

- 400 CFM Integrated Blower included
- Three fan speeds plus 10 minute high-power operation mode
- Dishwasher safe aluminum mesh filters
- Filter systems are highly efficient at capturing grease
- Powerfully quiet ventilation systems
- 6" Round duct size
- Vertical ducting direction
- All-in-one solution with an integral blower included
- Hood includes filters, backdraft damper and transition

### **Design**

- Suitable for wall or island applications
- Slide control for easy power adjustments
- Halogen lighting spotlights your best recipes

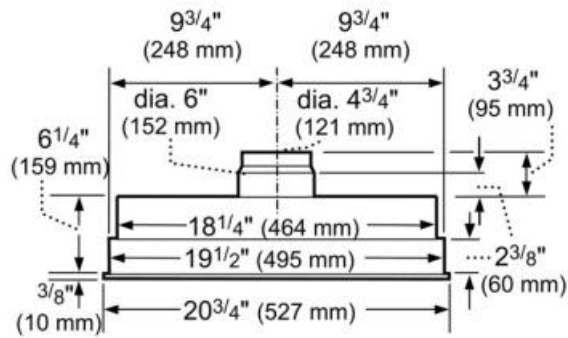

measurements in inches and mm

Frequency (Hz)	60
Approval certificates	ETL, UL
Plug type	120V-3 prong
Net weight (lbs)	19
Gross weight (lbs)	22
Required distance above range/rangetop/cooktop	30"/30"
Operating mode	Ducted
Number of lights	2
Type of lamps used	Halogen
Total power of the lamps (W)	40
Grease filter material	aluminium
Grease filter type	Multilayer cassette