



Performance

- Dual element offers the capability to use multiple pan sizes
- 2-level digital control panel indicates when elements are still hot

Design

- Trapezoid design control panel
- Heavy-duty, high quality metal knobs
- Full stainless steel frame
- Chiseled, angular design coordinates with the suite of Thermador Masterpiece® Collection appliances

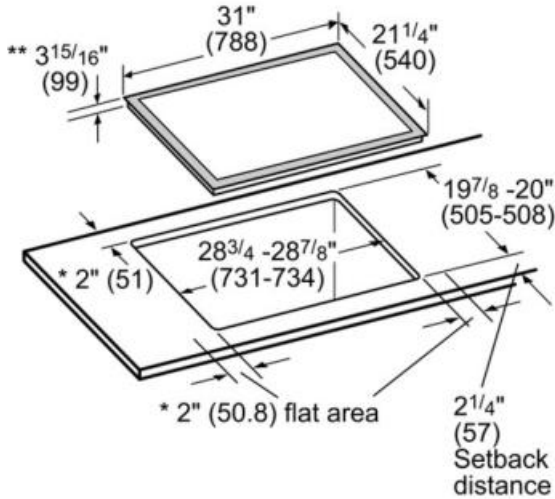
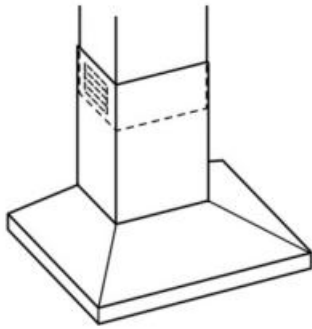

* Minimum distance from cutout to the wall
** Installed depth

Measurements in inches (mm in brackets)

Amps (A)	40; 30
Frequency (Hz)	60
Approval certificates	CSA
Plug type	no plug
Minimum distance from counter front (in)	2 1/4"
Minimum distance from rear wall (in)	2 3/4"
Net weight (lbs)	26
Sealed burners	No
Location of 1st heating element	front left
Dimension of 1st heating element (in)	6"
Power of 1st heating element (W)	1.2
Included accessories	1 x glass scraper
Location of 2nd heating element	back left
Dimension of 2nd heating element (in)	9", 6"
Power of 2nd heating element (W)	1.3 ; 3.1
Location of 3rd heating element	back right
Dimension of 3rd heating element (in)	8", 5"
Power of 3rd heating element (W)	0.75 ; 2.2
Location of 4th heating element	Cooking zone front right
Dimension of 4th heating element (in)	7"
Power of 4th heating element (W)	1.8