

CIT304KBB

30-INCH INDUCTION COOKTOP

MASTERPIECE® SERIES BLACK FRAMELESS



Also Available:

CIT304KB - Black with Stainless Steel Frame

CIT304KM - Silver Mirrored Finish

FEATURES & BENEFITS

- ★ - Our Induction PowerBoost® feature heats cookware faster than any other type of cooking technology
- Large and powerful 11" element with 3,600 W
- Speed heating induction cooktops heat faster than traditional gas and electric cooktops
- Auto Shut-Off Timer available for all elements enables user to set desired cooking times. Separate kitchen timer also available.
- Touch control panel with blue light illumination offers 17 power settings

ACCESSORIES (OPTIONAL)



SENSORPOT7
7" Ceramic Pot



CHEFSPAN08
10" Stainless Steel Pan

GENERAL PROPERTIES

Controls	Touch Controls
----------	----------------

ELEMENT PERFORMANCE

Power of Front Left Heating Element	2,200 W
Power of Front Left Heating Element (In Boost)	3,700 W
Power of Back Left Heating Element	1,400 W
Power of Back Left Heating Element (In Boost)	1,800 W
Power of Center Heating Element	N/A
Power of Center Heating Element (In Boost)	N/A
Power of Back Right Heating Element	2,400 W
Power of Back Right Heating Element (In Boost)	3,600 W
Power of Front Right Heating Element	1,400 W
Power of Front Right Heating Element (In Boost)	1,800 W
Burners With Booster	All 4

ELEMENT SIZE

Dimension of Front Left Heating Element	9"
Dimension of Back Left Heating Element	6"
Dimension of Center Heating Element	N/A
Dimension of Back Right Heating Element	11"
Dimension of Front Right Heating Element	6"

TECHNICAL DETAILS

Watts (W)	7,200 W
Circuit Breaker (A)	40 A
Volts (V)	208 / 240 V
Frequency (Hz)	50 / 60 Hz
Plug Type	No Plug
Conduit	39" Flexible 3-Wire
Energy Source	Electric

DIMENSIONS & WEIGHT

Overall Appliance Dimensions (HxWxD) (in)	3/8" + 3 7/8" x 31" x 21 1/4"
Required Cutout Size (HxWxD) (in)	3 7/8" x 28 3/4" x 19 7/8"
Minimum Distance From Counter Front (in)	2 1/2"
Minimum Distance From Rear Wall (in)	2 3/8"
Net Weight (lbs)	42 lbs

WARRANTY

Limited Warranty, Entire Appliance, Parts and Labor	2 Year
Limited warranty for glass ceramic surface / electronic elements and switches; parts	3rd to 5th Year

CIT304KBB
30-INCH INDUCTION COOKTOP
 MASTERPIECE® SERIES BLACK FRAMELESS



30-INCH COOKTOP AND CUTOUT DIMENSIONS

IMPORTANT: Thermador 30" Induction Cooktops are not approved to be installed above wall ovens.

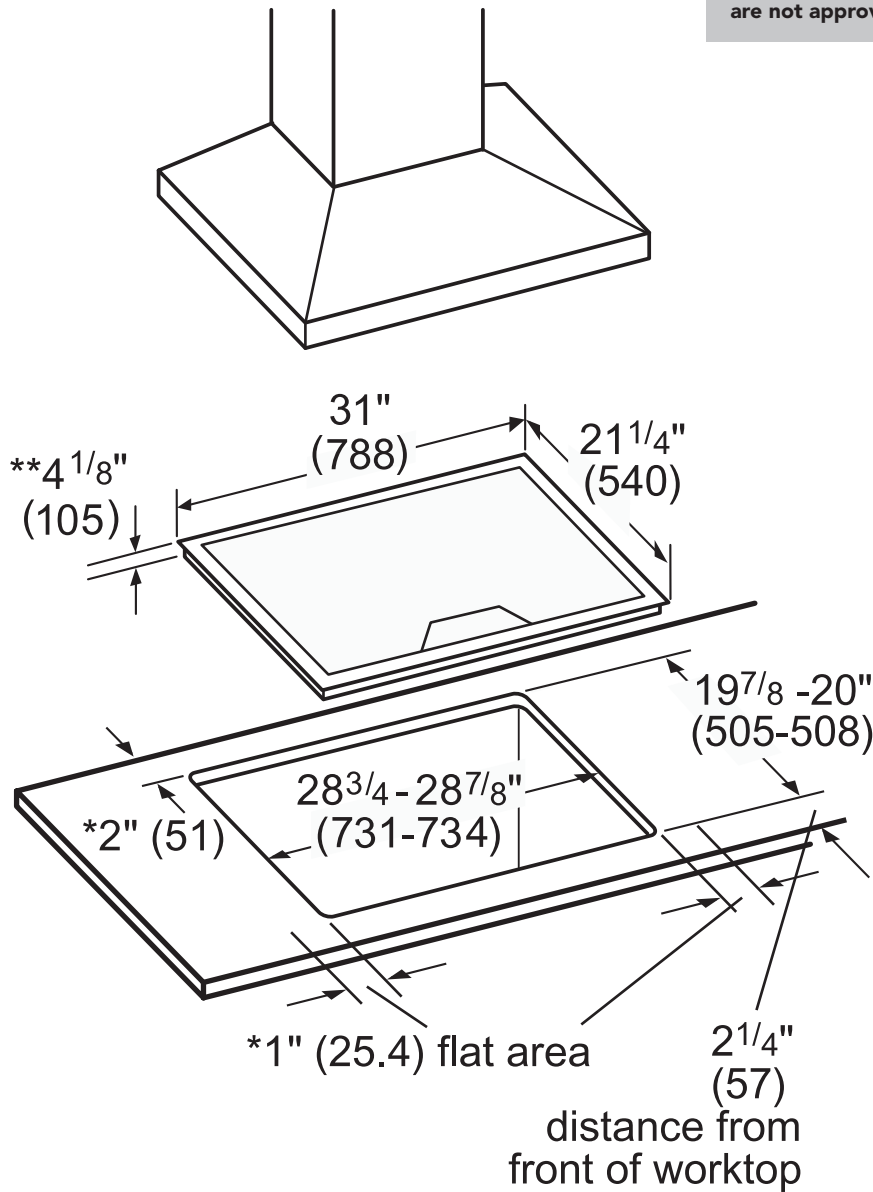

- * Minimum distance from cutout to the wall
- ** Recessed depth (includes 1" air clearance)

Measurements in inches (mm in brackets)

NOTE: The work surface should be horizontal and level. The stability of the countertop should be confirmed even after making the cutout.

These warranties give you specific legal rights and you may have other rights that vary from state to state. Full warranty and limited warranty from date of installation. For complete warranty details, refer to your Use & Care manual, or ask your dealer.

Specifications are for planning purposes only. Refer to installation instructions and consult your countertop supplier prior to making counter opening. Consult with a heating and ventilation engineer for your specific ventilation requirements. For the most detailed information, refer to installation instructions accompanying product or write to Thermador indicating the model number. Specifications are correct at time of printing. Thermador reserves the right to change product specifications or design without notice. Some models are certified for use in Canada. Thermador is not responsible for products that are transported from the U.S. for use in Canada.