



INDUCTION COOKTOPS MASTERPIECE® SERIES

Induction has been the most revolutionary advancement in cooking technology in the last 30 years. Now it's time for Thermador to inaugurate a new revolution: the Freedom® Induction Cooktop.

Never content to settle for status quo thinking, we have re-imagined the possibilities of induction cooking, giving cooks the industry's first induction cooktop with the largest, fully usable cooking surface. The Freedom® Induction Cooktop offers more responsiveness, more flexibility and the first full-color touch-screen interface on an induction cooktop. Our complete Induction Cooktop collection provides the speed and precision of PowerBoost® technology and features the largest and most powerful element in its class.

PopMech  12

INDUCTION COOKTOPS FEATURES & BENEFITS

FREEDOM® INDUCTION



★ ONE-OF-A-KIND INNOVATION

With over 30 international patents, the Freedom® Induction Cooktop represents a leap forward in induction cooking completely unique to Thermador.

★ ANYWHERE, ANY POSITION

Place up to 4 pots or pans anywhere on the cooktop surface, in any configuration. The cooking surface is optimized to work with a pan as small as 3" and as large as 13" x 21" —delivering Real Innovations for Real Cooks®.

★ FREEDOM TO MOVE

The Freedom® Induction cooking surface automatically detects the presence of your cookware. If you need to move your pot to another location, the cooktop will transfer all of your programmed settings to the new position of the pan.

STANDARD INDUCTION

★ TRIPLE ELEMENT

Only activates the heating zone directly in contact with the pot surface so pans of different sizes are heated more efficiently.

★ 13-INCH ELEMENT

The largest cooking element on the market provides 40% more usable cooking area than competing cooktops. Ideal for accommodating oversized skillets, pots and pans.

SUPERIOR RESPONSIVENESS

Induction technology allows instantaneous temperature changes as the power level is adjusted, making it as responsive and flexible as gas cooktops.

★ THERMADOR EXCLUSIVE

★ LARGEST COOKING SURFACE

The Freedom® Induction Cooktop delivers 63% more usable surface area than the competition, with 48 coils measuring 3" each — offering the largest cooking surface on the market.

SAFETY / CLEAN LOCK

A critical feature for a touch-screen interface, Clean Lock prevents unwanted changes to your cooking settings.



★ POWERBOOST®

To bring foods to the desired temperature in the shortest possible time, the PowerBoost function will deliver a maximum power output from 3,600 W to 4,600 W.



★ BRILLIANT INTERFACE

Featuring the first full-color touch screen induction panel on the market: clear text displays, cookware display, a 6.5" color screen with touch-through glass. Our intuitive interface offers better control and faster access to cooking settings.



★ A SOPHISTICATED ALTERNATIVE

In addition to black, we offer a stunning silver mirrored finish to create a unique design statement for the contemporary kitchen.



TIMERS FOR ALL ELEMENTS

Each burner features its own element shut-off timer, making it easier to coordinate the cooking of multiple dishes.

INDUCTION COOKTOPS PLANNING INFORMATION

MODEL OPTIONS

There are two sizes of induction cooktops to choose from — 30-inch and 36-inch. Models are available in our original black finish as well as our silver mirrored finish for those who want a bold, striking alternative that goes perfectly with stainless steel appliances. Be sure to reference the correct model information in this design guide.

INSTALLATION CONSIDERATIONS

The information in this design guide provides key features, product dimensions, cutouts and installation specifications. Before installing a Thermador Induction Cooktop, be sure to verify the cutout dimensions and electrical connections. Also, always consult with the installation manual packed with the product for complete details before installing.

36" Thermador Induction Cooktops may be installed above a Thermador Single Built-in Oven. A minimum 1" air gap must be maintained between the bottom of the cooktop and the top of the oven. **See below for approved cooktop over oven installation.**

MODEL	APPROVED COOKTOP OVER THERMADOR OVEN INSTALLATION
CIT36XKB	•
CIT36XKBB	•
CIT365KB	•
CIT365KM	•
CIT365KBB	•
CIT304KB	
CIT304KM	
CIT304KBB	

Cooktops that are not listed above, must be approved under local code and / or by the local authority having jurisdictions.

Thermador Cooktops may also be installed above a Thermador Warming Drawer to create a convenient cooking center. Refer to the warming drawer section for additional specifications.

Solid surface countertops often require special installation. For example, heat reflective tape or rounded corners may be necessary. Contact the countertop manufacturer for instructions specific to your countertop.

We strongly recommend the installation of a Thermador Ventilation System with this induction cooktop. Refer to the ventilation section for specifications.

WARRANTY

Limited warranty parts and labor (2 year)



Limited warranty for glass ceramic surface / electronic elements and switches; Parts only (3rd to 5th year)

See page 310 for additional warranty details.

ELECTRICAL SPECIFICATIONS

Be sure your appliance is properly installed and grounded by a qualified technician. Installation, electrical connections and grounding must comply with all applicable local codes.

All induction cooktops are dual rated, designed to be connected to either 240/208V AC, 60 Hz, 3-wire, single-phase power supply.

Install a suitable conduit box (not furnished). An appropriately-sized, UL-listed conduit connector must be used to correctly attach the conduit to the junction box.

MODEL	REQUIRED CIRCUIT BREAKER	
	240V, 3-Wire, 60 Hz	208V, 3-Wire, 60 Hz
CIT36XKB	40 Amp	40 Amp
CIT36XKBB	40 Amp	40 Amp
CIT365KB	50 Amp	50 Amp
CIT365KM	50 Amp	50 Amp
CIT365KBB	50 Amp	50 Amp
CIT304KB	40 Amp	40 Amp
CIT304KM	40 Amp	40 Amp
CIT304KBB	40 Amp	40 Amp

IMPORTANT: Local Codes may vary; installation, electrical connections and grounding must comply with all applicable local codes. If required by the National Electrical Code (or Canadian Electrical Code), this appliance must be installed on a separate branch circuit.

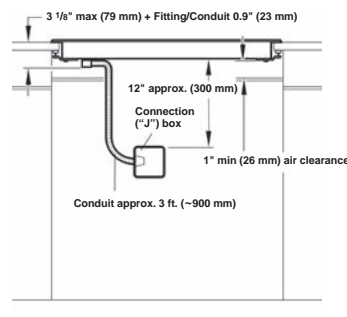

ELECTRICAL LOCATION

The junction box must be located within 3 feet (~900 mm) of the cooktop connection. It should be easily accessible for service purposes.

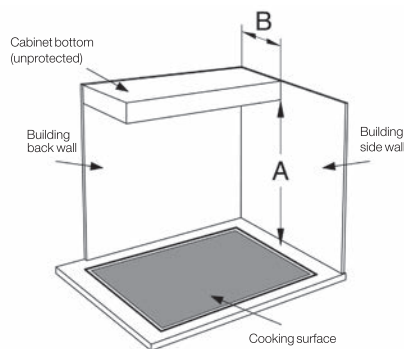

CABINET REQUIREMENTS

The distance from the top of the cooktop to the bottom of the cabinets above it must be A = 30" (762 mm) minimum. This distance can be reduced to A = 24" (610 mm) when the bottom of the wood or metal cabinet is protected by not less than 1/4" (6.35 mm) flame retardant millboard, covered by no. 28 steel sheet 0.015 (.4 mm) thick stainless steel, 0.024" (0.6 mm) aluminum, or 0.020" (0.5 mm) thick copper, at a minimum. Verify that the cabinets above the cooktop are a maximum of B = 13" (330 mm) deep.

COOKTOPS

36-INCH FREEDOM® INDUCTION

CIT36XKB / CIT36XKBB



MASTERPIECE®
CIT36XKB – Black Finish



MASTERPIECE®
CIT36XKBB – Frameless

SPECIFICATIONS

Total Number of Cooktop Elements	Full Surface, Maximum 4 Pots
Product Width	37"
Product Depth	21 1/4"
Cutout Width	34 3/4" – 34 7/8"
Cutout Height	3 1/8"
Minimum Air Clearance	1"
Total Cutout Height (Including Air Clearance)	4 1/8"
Cutout Depth	19 7/8" – 20"
Minimum Distance from Counter Front	2 1/4"
Minimum Distance from Rear Wall	2"
Freedom® Full Surface Induction Cooktop	3" x 3" Minimum Cookware Size* 15 W / 500 W 13" x 21" Maximum Cookware Size* 100 W / 4,600 W
Electrical Supply	240/208V AC, 60 Hz
Required Circuit Breaker	40 Amp
Conduit	39" Flexible 3-Wire
Shipping Weight (lbs.)	62

*Cookware less than 3" will not be recognized. Theoretical maximum cookware size is 13" x 27". Cookware must have a flat bottom in order to utilize the full surface.

CIT36XKB / CIT36XKBB

INNOVATION

- ★ - Largest fully usable cooking surface on the market
- ★ - 48 induction elements deliver more than 63% usable cooking surface than the competition
- ★ - Place up to 4 pots or pans anywhere on the cooktop surface in any configuration
- ★ - Featuring the first full color touchscreen induction user interface on the market, offering better control and faster access to cooking settings
- ★ - Freedom to move - if you need to move your pot to another location, the cooktop will transfer all of your programmed settings to the new position of the pan

PERFORMANCE

- Most powerful element in its class with a 4,600 W PowerBoost™ lets you boil water faster than with any other cooking technology
- Speed Heating - Induction cooktops heat 50% faster than traditional gas cooktops
- Pan Recognition - Element will not turn on if other small objects are placed on the cooking zone
- Anti-Overflow System - exclusive feature shutting off the relevant element and sounding alarm when liquids are detected on user interface
- Child Safety Lock

DESIGN

- Available with full stainless steel frame or frameless
- Grey-black glass color
- Angular, modern design coordinates with the suite of Thermador Masterpiece™ Collection appliances

★ THERMADOR EXCLUSIVE

ACCESSORIES



SENSORPOT7
7" Ceramic Pot



CHEFSPAN13
16" Round Skillet



TEPPAN1321
Griddle Style
Teppanyaki
13" x 21"



TEPPAN1314
Griddle Style
Teppanyaki
13" x 14"

INSTALLATION OPTIONS

INSTALLATION ABOVE A BUILT-IN OVEN OR WARMING DRAWER

Thermador Induction Cooktops may be installed above a Thermador Single Built-in Oven. A minimum 1" air gap must be maintained between the bottom of the cooktop and the top of the oven.

Thermador Cooktops may also be installed above a Thermador Warming Drawer to create a convenient cooking center. Refer to the warming drawer section for additional specifications.

IMPORTANT

We strongly recommend the installation of a Thermador Ventilation System with this induction cooktop.

Seal the surfaces of the cutout to make them heat resistant. This prevents the surfaces from expanding as a result of humidity.

Solid surface countertops often require special installation. For example, heat reflective tape or rounded corners may be necessary. Contact the countertop manufacturer for instructions specific to your countertop.

WARNING

To reduce the risk of ignition of nearby combustible materials, install the countertop with a minimum distance of 2" (51 mm) from both side walls and the back wall.

HEAT SHIELD

The heat shield will require an additional 1" clearance below the cooktop. For safety reasons, the heat shield must be properly installed. This prevents components from overheating as a result of the recirculation of hot air from the cooktop. The heat shield is the same width as the cooktop. For shipping, it is screwed to the burner box. Once installed, the heat shield will be able to rotate freely, as shown in the illustration. Refer to the instructions packed with product for installation details.

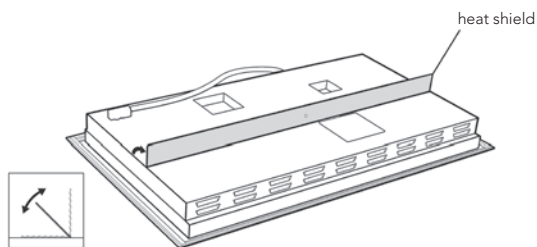

36-INCH COOKTOP AND CUTOUT DIMENSIONS

NOTE: The work surface should be horizontal and level. The stability of the countertop should be confirmed even after making the cutout.

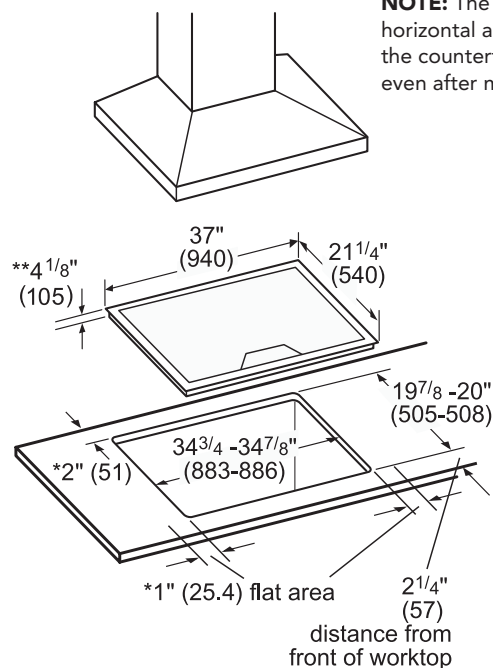

- * Minimum distance from cutout to the wall
- ** Recessed depth (includes 1" air clearance)

Measurements in inches (mm in brackets)

INSTALLATION ABOVE A THERMADOR BUILT-IN OVEN

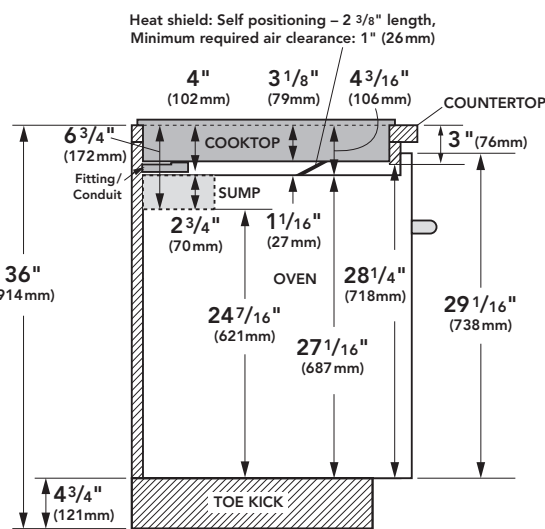

Note: Dimensions based on standard countertop height (36" with 4 3/4" toe kick including base plate).

The built-in oven can be installed below the induction cooktop as long as there is an air clearance of 1" between the bottom of the cooktop and the top of the oven.

Sump applies to 30-inch Wall Ovens only.

COOKTOPS

36-INCH INDUCTION

CIT365KB / CIT365KM / CIT365KBB



MASTERPIECE®
CIT365KB – Black Finish

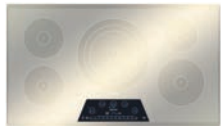

MASTERPIECE®
CIT365KM – Silver Mirrored Finish



MASTERPIECE®
CIT365KBB – Frameless

SPECIFICATIONS

Total Number of Cooktop Elements	5
Product Width	37"
Product Depth	21 1/4"
Cutout Width	34 3/4" – 34 7/8"
Cutout Height	3 1/8"
Minimum Air Clearance	1"
Total Cutout Height (Including Air Clearance)	4 1/8"
Cutout Depth	19 7/8" – 20"
Minimum Distance from Counter Front	2 1/4"
Minimum Distance from Rear Wall	2"
Left Front Element (Size / W / W w/PowerBoost)	7" / 1,800 W / 2,500 W
Right Front Element (Size / W / W w/PowerBoost)	9" / 2,200 W / 3,700 W
Left Rear Element (Size / W / W w/PowerBoost)	7" / 1,800 W / 2,500 W
Right Rear Element (Size / W / W w/PowerBoost)	6" / 1,400 W / 1,800 W
Center Element (Size / W / W w/PowerBoost)	13" / 3,300 W / 4,600 W
Outer Ring	11" / 2,600 W / 3,400 W
Middle Ring	9" / 2,200 W / 3,300 W
Inner Ring	9" / 2,200 W / 3,300 W
Electrical Supply	240/208V AC, 60 Hz
Required Circuit Breaker	50 Amp
Conduit	39" Flexible 3-Wire
Shipping Weight (lbs.)	61

CIT365KB / CIT365KM / CIT365KBB

INNOVATION

- ★ - Silver Mirrored Finish – striking and bold design offers the perfect companion solution for stainless steel products (CIT365KM)
- ★ - Largest (13") and most powerful (4,600 W) round heating element on the market in its class
- ★ - Industry exclusive triple zone – accommodates multiple size pans with 3 diameter sizes

PERFORMANCE

- Speed Heating – Induction cooktops heat 50% faster than traditional gas cooktops
- Our Induction PowerBoost® feature heats cookware faster than any other type of cooking technology.
- Auto Shut-Off Timer available for all elements enables user to set desired cooking times. Separate kitchen timer also available.
- Keep Warm function allows meals to remain ready to serve
- Pan Recognition – Element will not turn on if other small objects are placed on the cooking zone
- Anti-Overflow System – exclusive feature prevents spills by automatically shutting off and sounding alarm when liquids are detected on surface
- 2-step digital control panel indicates when elements are hot or very hot
- Child safety lock

DESIGN

- Touch control panel with blue light illumination offers 17 power settings
- Chiseled, angular design coordinates with the suite of Thermador Masterpiece® Collection appliances
- Full stainless steel frame (CIT365KB)
- Trapezoid design control panel

★ THERMADOR EXCLUSIVE

ACCESSORIES



SENSORPOT7
7" Ceramic Pot



CHEFSPAN13
16" Round Skillet

INSTALLATION OPTIONS

INSTALLATION ABOVE A BUILT-IN OVEN OR WARMING DRAWER

Thermador Induction Cooktops may be installed above a Thermador Single Built-in Oven. A minimum 1" air gap must be maintained between the bottom of the cooktop and the top of the oven.

Thermador Cooktops may also be installed above a Thermador Warming Drawer to create a convenient cooking center. Refer to the warming drawer section for additional specifications.

IMPORTANT

We strongly recommend the installation of a Thermador Ventilation System with this induction cooktop.

Seal the surfaces of the cutout to make them heat resistant. This prevents the surfaces from expanding as a result of humidity.

Solid surface countertops often require special installation. For example, heat reflective tape or rounded corners may be necessary. Contact the countertop manufacturer for instructions specific to your countertop.

WARNING

To reduce the risk of ignition of nearby combustible materials, install the countertop with a minimum distance of 2" (51 mm) from both side walls and the back wall.

HEAT SHIELD

The heat shield will require an additional 1" clearance below the cooktop. For safety reasons, the heat shield must be properly installed. This prevents components from overheating as a result of the recirculation of hot air from the cooktop. The heat shield is the same width as the cooktop. For shipping, it is screwed to the burner box. Once installed, the heat shield will be able to rotate freely, as shown in the illustration. Refer to the instructions packed with product for installation details.

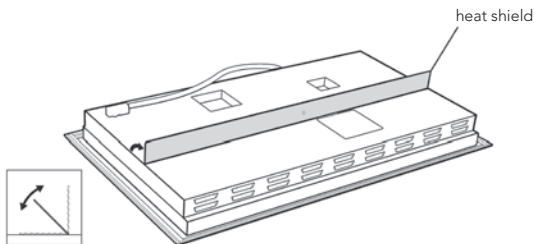

36-INCH COOKTOP AND CUTOUT DIMENSIONS

NOTE: The work surface should be horizontal and level. The stability of the countertop should be confirmed even after making the cutout.

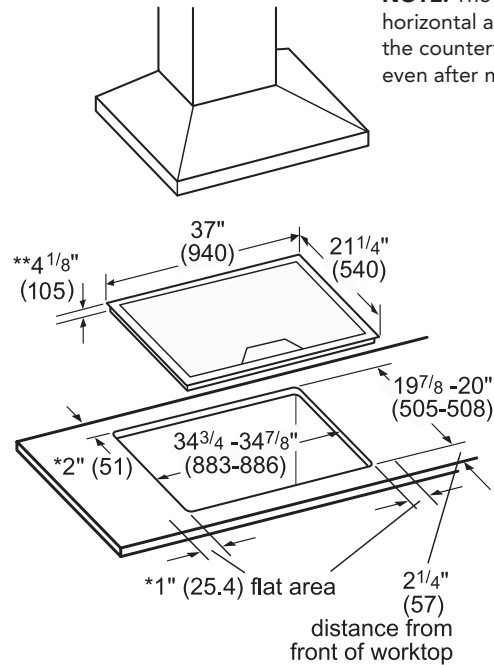

- * Minimum distance from cutout to the wall
- ** Recessed depth (includes 1" air clearance)

Measurements in inches (mm in brackets)

INSTALLATION ABOVE A THERMADOR BUILT-IN OVEN

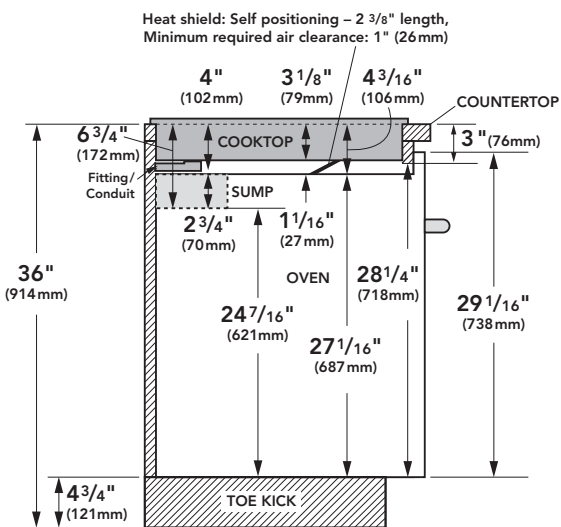

Note: Dimensions based on standard countertop height (36" with 4 3/4" toe kick including base plate).

The built-in oven can be installed below the induction cooktop as long as there is an air clearance of 1" between the bottom of the cooktop and the top of the oven.

Sump applies to 30-inch Wall Ovens only.

COOKTOPS

30-INCH INDUCTION

CIT304KB / CIT304KM / CIT304KBB



MASTERPIECE®

CIT304KB – Black Finish



MASTERPIECE®

CIT304KM – Silver Mirrored Finish



MASTERPIECE®

CIT304KBB – Frameless

SPECIFICATIONS

Total Number of Cooktop Elements	4
Product Width	31"
Product Depth	21 1/4"
Cutout Width	28 3/4" – 28 7/8"
Cutout Height	3 1/8"
Minimum Air Clearance	1"
Total Cutout Height (Including Air Clearance)	4 1/8"
Cutout Depth	19 7/8" – 20"
Minimum Distance from Counter Front	2 1/4"
Minimum Distance from Rear Wall	2"
Left Front Element (Size / W / W with PowerBoost)	9" / 2,200 W / 3,700 W
Right Front Element (Size / W / W with PowerBoost)	6" / 1,400 W / 1,800 W
Left Rear Element (Size / W / W with PowerBoost)	6" / 1,400 W / 1,800 W
Right Rear Element (Size / W / W with PowerBoost)	11" / 2,400 W / 3,600 W
Electrical Supply	240/208V AC, 60 Hz
Required Circuit Breaker	40 Amp
Conduit	3/4" Flexible 3-Wire
Shipping Weight (lbs.)	49

CIT304KB / CIT304KM / CIT304KBB

INNOVATION

- ★ - Silver Mirrored Finish – striking and bold design offers the perfect companion solution for stainless steel products (CIT304KM)

PERFORMANCE

- Speed Heating – Induction cooktops heat 50% faster than traditional gas cooktops
- Large and powerful 11" element with 3,600 W
- Our Induction PowerBoost® feature heats cookware faster than any other type of cooking technology.
- Auto Shut-Off Timer available for all elements enables user to set desired cooking times. Separate kitchen timer also available.
- Keep Warm function allows meals to remain ready to serve
- Pan Recognition – Element will not turn on if other small objects are placed on the cooking zone
- Anti-Overflow System – exclusive feature prevents spills by automatically shutting off and sounding alarm when liquids are detected on surface
- 2-step digital control panel indicates when elements are hot or very hot
- Child safety lock

DESIGN

- Touch control panel with blue light illumination offers 17 power settings
- Chiseled, angular design coordinates with the suite of Thermador Masterpiece® Collection appliances
- Full stainless steel frame (CIT304KB)
- Trapezoid design control panel

★ THERMADOR EXCLUSIVE

ACCESSORIES



SENSORPOT7
7" Ceramic Pot



CHEFSPAN13
16" Round
Skillet

INSTALLATION

INSTALLATION ABOVE WARMING DRAWER

Thermador Cooktops may also be installed above a Thermador Warming Drawer to create a convenient cooking center. Refer to the warming drawer section for additional specifications.

IMPORTANT

We strongly recommend the installation of a Thermador Ventilation System with this induction cooktop.

Seal the surfaces of the cutout to make them heat resistant. This prevents the surfaces from expanding as a result of humidity.

Solid surface countertops often require special installation. For example, heat reflective tape or rounded corners may be necessary. Contact the countertop manufacturer for instructions specific to your countertop.

WARNING

To reduce the risk of ignition of nearby combustible materials, install the countertop with a minimum distance of 2" (51 mm) from both side walls and the back wall.

HEAT SHIELD

The heat shield will require an additional 1" clearance below the cooktop. For safety reasons, the heat shield must be properly installed. This prevents components from overheating as a result of the recirculation of hot air from the cooktop. The heat shield is the same width as the cooktop. For shipping, it is screwed to the burner box. Once installed, the heat shield will be able to rotate freely, as shown in the illustration. Refer to the instructions packed with product for installation details.

30-INCH COOKTOP AND CUTOUT DIMENSIONS

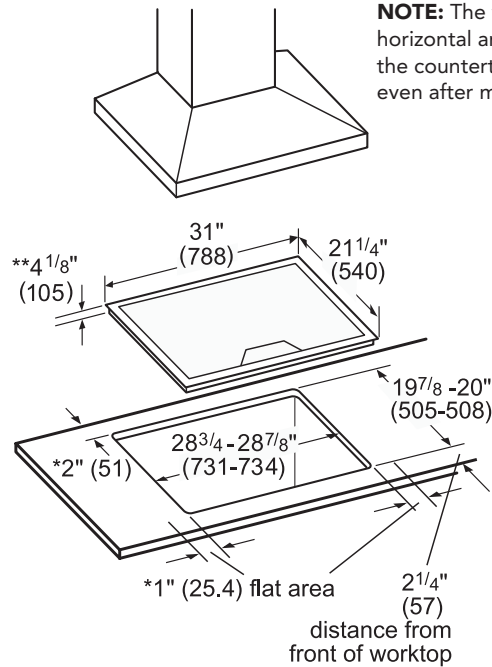

- * Minimum distance from cutout to the wall
- ** Recessed depth (includes 1" air clearance)

Measurements in inches (mm in brackets)

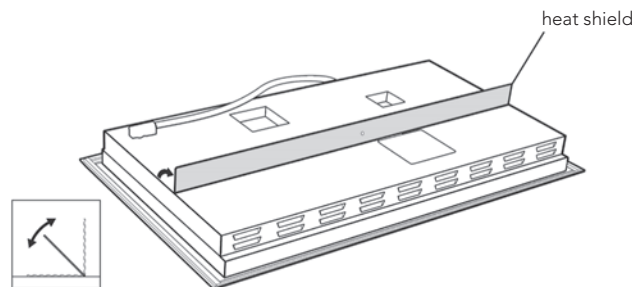

EXPERIENCE THERMADOR®

Thermador is committed to giving you an enjoyable, creative and rewarding cooking experience. Whether you would like to research our products, watch a video of our chef searing the perfect scallop, or have questions on the use and care of your product, simply browse our online resource library at thermador.com

CONNECT WITH US

thermador.com/blog

 [facebook.com](https://www.facebook.com/thermador)

 twitter.com/thermador

 [youtube.com/thermadorhome](https://www.youtube.com/thermadorhome)

 [pinterest.com/thermador](https://www.pinterest.com/thermador)

 [instagram.com/thermadorhome](https://www.instagram.com/thermadorhome)

VISIT THE ABOVE SITES TO SHARE PHOTOS OF
YOUR NEW KITCHEN AND CREATIVE DISHES.

TAKE US WITH YOU

Visit the App Store™ or Google Play™ to download our Innovations app, including the Thermador Kitchen Ideas & Lookbook and the Thermador Kitchen Design and Planning Guide.

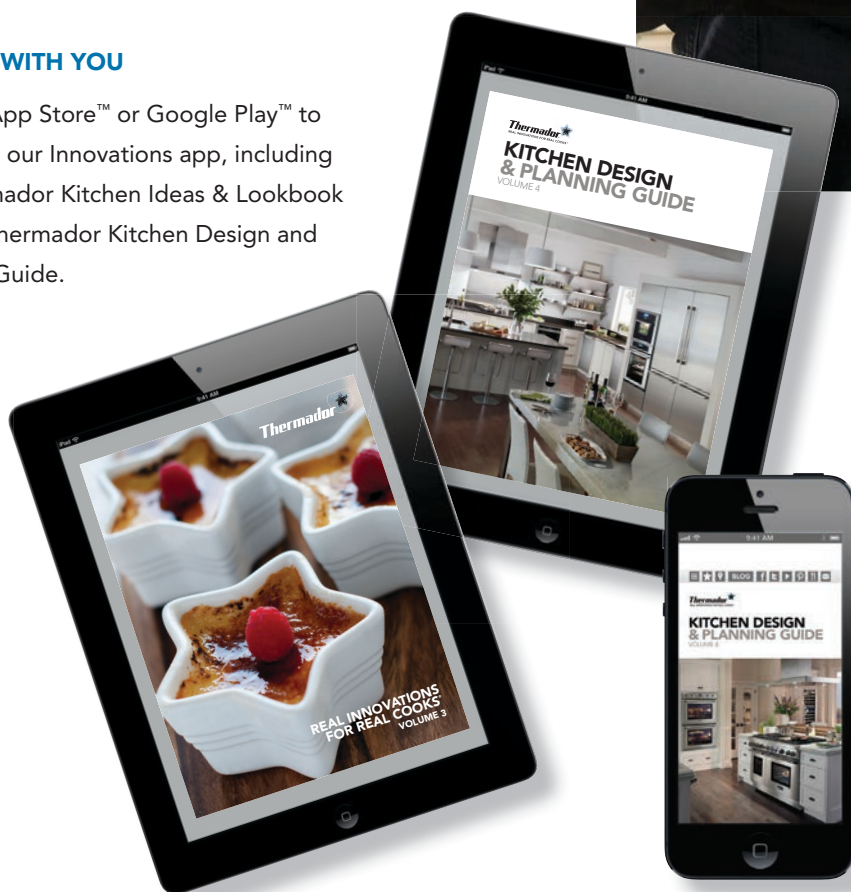

CUSTOMER SERVICE

For dedicated customer service on any Thermador product, please call: 1-800-735-4328 or contact us at thermador.com



1 800 735 4328

USA THERMADOR.COM
CANADA THERMADOR.CA