

T24UR800DP UNDER-COUNTER DOUBLE DRAWER REFRIGERATOR

CUSTOM PANEL-READY



Also Available:

T24UR820DS - with Professional Series Handle

T24UR810DS - with Masterpiece® Series Handle

FEATURES & BENEFITS

- Customizable cooling modes—Fridge, Pantry and Bar
- ★ - SoftClose® drawers for ultra-smooth closing
- Customizable drawer dividers and shelving
- Quick Chill
- LED Lighting
- Drawer mats keep items from sliding and remove for easy cleaning
- Touch electronic controls for precise temperature management

GENERAL PROPERTIES

Panel Ready	Yes
SoftClose® Drawers	Yes
Lighting	LED Lighting
Customizable Aluminum Dividers / Shelving	Yes
Removable Drawer Mats	Yes
Full Extension Drawers	Yes
Drawer Open Alarm	Yes
Quick Chill	Yes
Touch Electronic Controls	Yes

CAPACITY

Total Unit Gross Capacity (cu. ft.) - AHAM	5 cu ft.
--	----------

TEMPERATURE RANGES

Refrigerator	33°F (0.5°C) to 58°F (14.5°C)
Pre-Set Cooling Modes	Refrigerator 37°F (3°C) Pantry 53°F (12°C) Bar 34°F (1°C)
Quick Chill	Yes

TECHNICAL DETAILS

Watts (W)	149.5 W
Current (A)	15 or 20 Amp
Volts (V)	115 V
Frequency (Hz)	60 Hz
Power Cord Length (in.)	50"
Plug Type	120V 3-Wire

DIMENSIONS & WEIGHT

Appliance Dimensions (H x W x D) (in.)	34 1/2"* x 23 7/8" x 23 7/8"
Required Cutout Size (H x W x D) (in.)	34-35" x 24" x 24"
Net / Gross Weight (lbs)	149 / 162 lbs

EFFICIENCY

ENERGY STAR® Qualified	No
Annual Energy Consumption	256 kWh

WARRANTY

Limited, Entire Appliance, Parts and Labor on Any Part of the Refrigerator that Fails Because of a Manufacturing Defect	2 Year
Limited Warranty for Sealed Refrigeration System*; Parts and Labor	7th to 12th Year
Limited Warranty for Sealed Refrigeration System*; Parts Only	7th to 12th Year

*Height Adjustable + / -1/2" (+ / -13 mm)

**Sealed refrigeration system includes compressor, evaporator, condenser, dryer / strainer and connection tubing

T24UR800DP

UNDER-COUNTER DOUBLE DRAWER REFRIGERATOR

CUSTOM PANEL-READY



DOUBLE DRAWER REFRIGERATOR AND CUTOUT DIMENSIONS

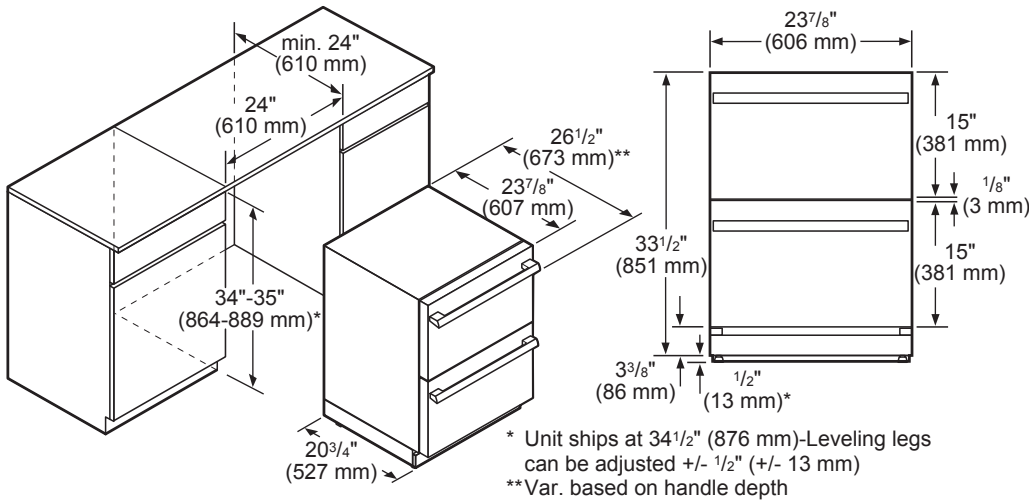

ELECTRICAL INSTALLATION

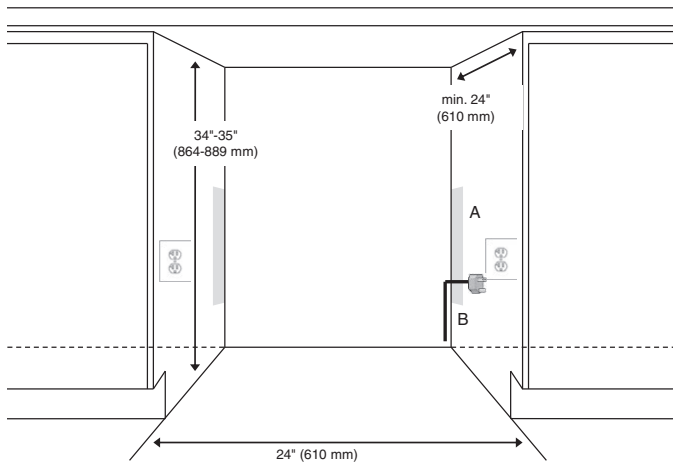

A: Recommended area for installation of power connection – a 2 1/2" (63 mm) diameter hole is recommended
 B: Location of power cord – approximately 15" (381 mm) from base of appliance

These warranties give you specific legal rights and you may have other rights that vary from state to state. Full warranty and limited warranty from date of installation. For complete warranty details, refer to your Use & Care manual, or ask your dealer.

Specifications are for planning purposes only. Refer to installation instructions and consult your countertop supplier prior to making counter opening. Consult with a heating and ventilation engineer for your specific ventilation requirements. For the most detailed information, refer to installation instructions accompanying product or write to Thermador indicating the model number. Specifications are correct at time of printing. Thermador reserves the right to change product specifications or design without notice. Some models are certified for use in Canada. Thermador is not responsible for products that are transported from the U.S. for use in Canada.