



Microwave Hood Combination

PRODUCT MODEL NUMBERS

GMH3174XV	MH1160XS	WMH1162XV
GMH3204XV	MH1170XS	WMH1164XV
GMH5184XV	MH1171XV	WMH2175XV
GMH5205XV	MH2175XS	WMH2205XV
GMH6185XV		WMH3205XV

Electrical: A 120-Volt, 60-Hz, AC-only, 15- or 20-amp fused electrical supply with a fuse or circuit breaker. A time-delay fuse or time-delay circuit breaker is recommended. It is recommended that a separate circuit serving only this microwave oven be provided.

VENTING REQUIREMENTS

A 3 1/4" x 10" (8.3 x 25.4 cm) rectangular or 6" (15.2 cm) round vent should be used. The total length of the vent system including straight vent, elbow(s), transitions and wall or roof caps must not exceed the equivalent of 140 ft (42.7 m) for either type of vent. For best performance, use no more than three 90° elbows. To calculate the length of the system you need, add the equivalent length for each vent piece used in the system. See the following examples:

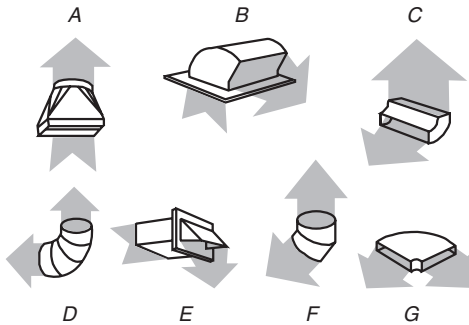

- A. Rectangular to round transition piece: 3 1/4" x 10" to 6" = 5 ft (8.3 x 25.4 cm to 15.2 cm = 1.5 m)
- B. Roof cap: 3 1/4" x 10" = 24 ft (8.3 x 25.4 cm = 7.3 m)
- C. 90° elbow: 3 1/4" x 10" = 25 ft (8.3 x 25.4 cm = 7.6 m)
- D. 90° elbow: 6" = 10 ft (15.2 cm = 3 m)
- E. Wall cap: 3 1/4" x 10" = 40 ft (8.3 x 25.4 cm = 12.2 m)
- F. 45° elbow: 6" = 5 ft (15.2 cm = 1.5 m)
- G. 90° flat elbow: 3 1/4" x 10" = 10 ft (8.3 x 25.4 cm = 3 m)

6" (15.2 cm) vent system = 73 ft (22.2 m) total

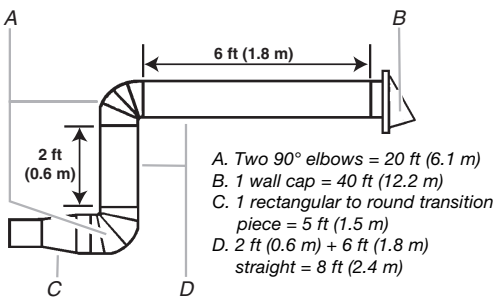

3 1/4" x 10" (8.3 x 25.4 cm) vent system = 73 ft (22.2 m) total

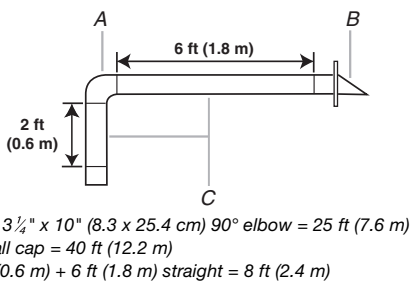

PRODUCT DIMENSIONS

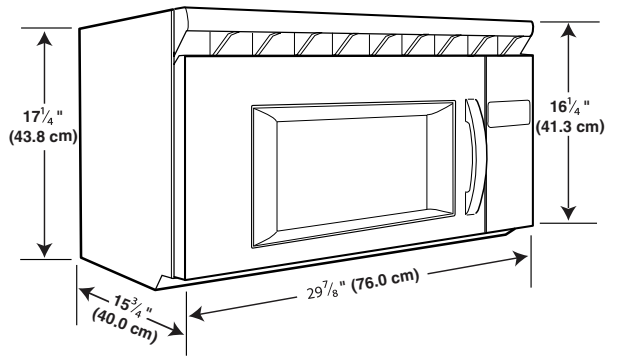

CABINET OPENING DIMENSIONS

The grounded 3-prong outlet must be inside the upper cabinet.

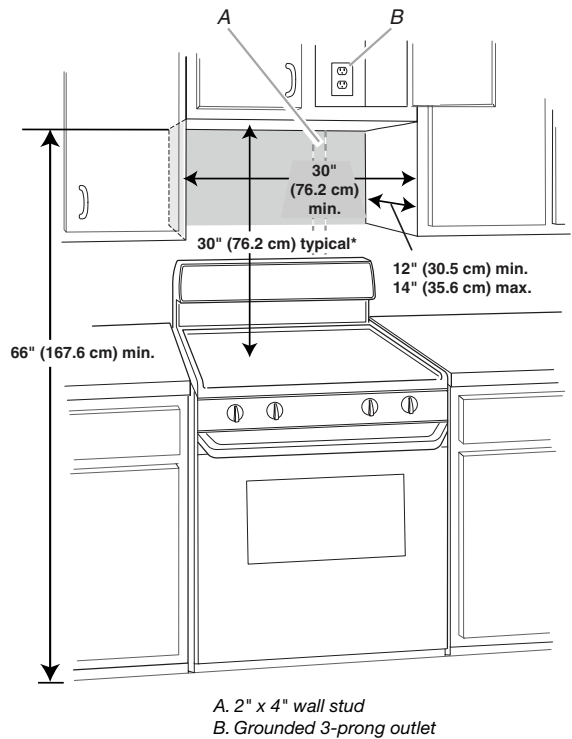

*30" (76.2 cm) is typical for 66" (167.6 cm) installation height. Exact dimensions may vary depending on type of range/cooktop below.

Rectangular to Round Transition for Roof Venting

NOTE: The minimum 3" (7.6 cm) clearance must exist between the top of the microwave oven and the rectangular to round transition piece so that the damper can open freely and fully.

