



## Under-the-Cabinet Microwave Oven

### PRODUCT MODEL NUMBERS

MT4078SP

**Electrical:** A 120-volt, 60-Hz, AC-only, 15- or 20-amp grounded electrical supply located in the upper cabinet or as close as possible to the microwave oven. A time-delay fuse or circuit breaker and separate circuit is recommended.

### OVERALL DIMENSIONS

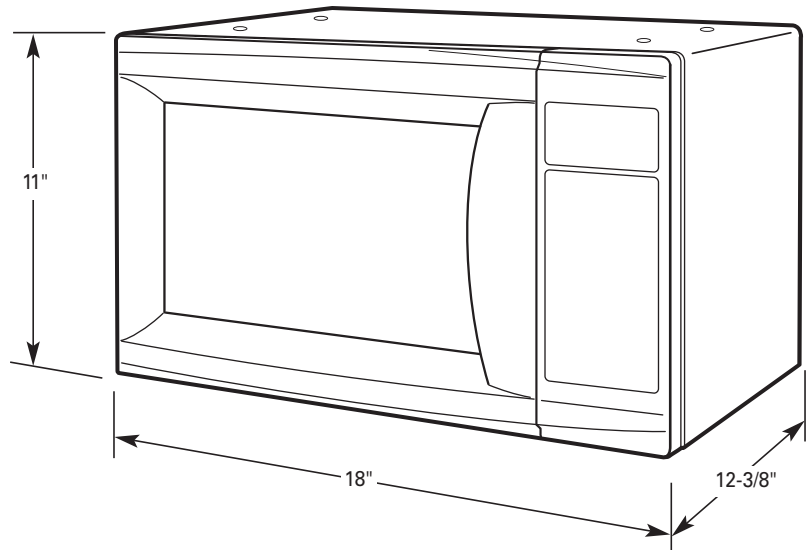

This microwave oven is intended for installation over a countertop. Do not install this microwave oven above any heat source such as a range or cooktop.

The cabinet must be a minimum of 12" (30.5 cm) deep. The bottom shelf of your cabinet must be at least 3/16" (4.8 mm) thick and strong enough to support an additional weight of 90 lbs (41 kg).

**NOTE:** This weight is in addition to the normal contents of the cabinet, as well as any other objects hung from the bottom of the cabinet.

To provide for adequate ventilation, do not install the microwave closer than 2-9/16" (6.5 cm) to a side wall.