

ZSI-E30AS

ZSI-E36AS

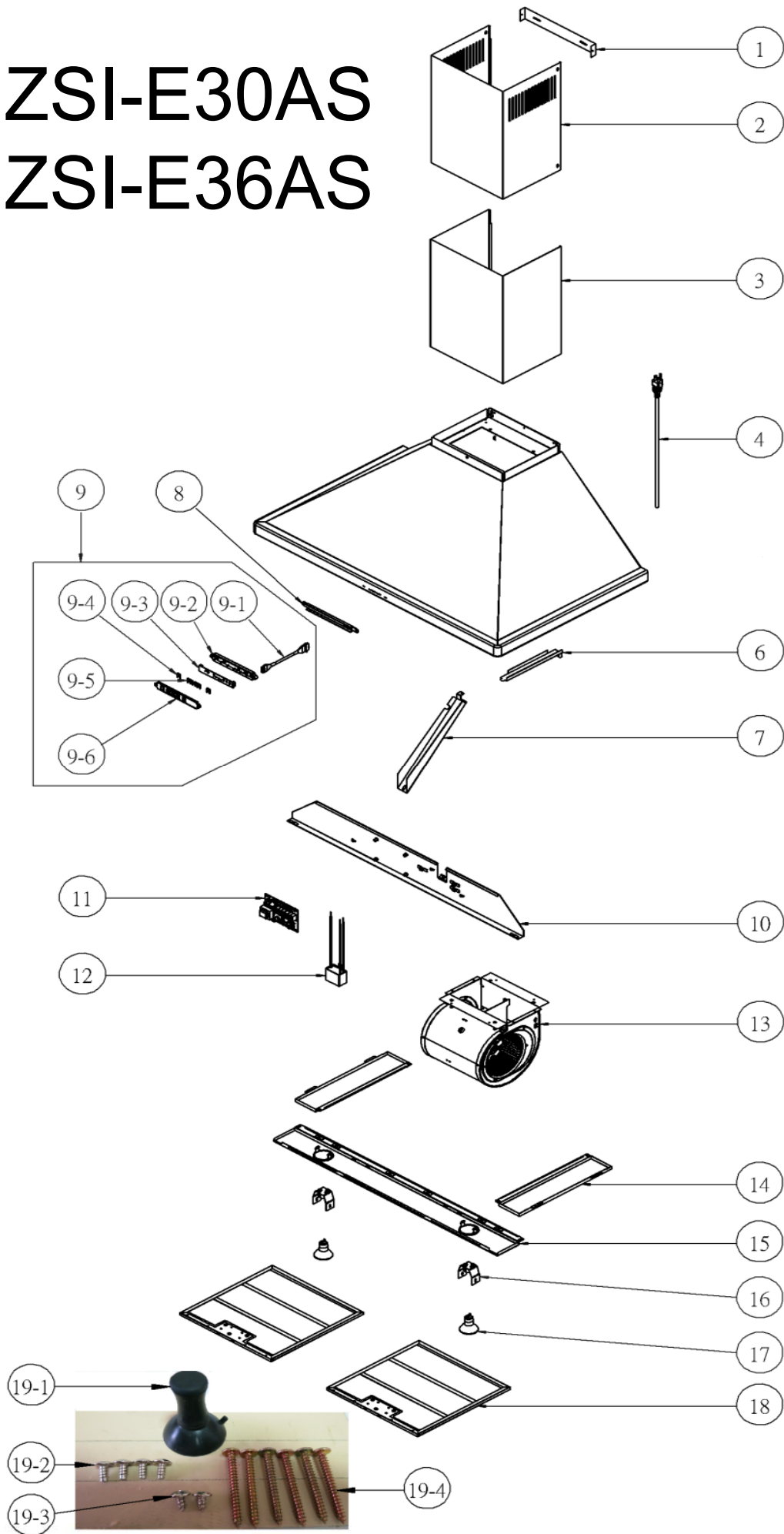

ZEPHYR

Siena Wall

ZSI-E30AS, ZSI-E36AS

Ref #	Part #	Description	Qty.
1	54110050	Bracket, Duct Cover	1
2	50050145	Duct Cover, Upper	1
3	50050146	Duct Cover, Lower	1
4	11030082	Wires, Electrical	1
6	54210008	Cover, Wiring	1
7	54210009	Cover, Wiring	1
8	54140154	Bracket, Switch	1
9	11000083	Switch Assembly	1
9-1	11030080	Cable, Switch	1
9-2	56200082	Housing, Switch	1
9-3	11010062	Switch Board	1
9-4	56240020	Spacer, Switch, Small	2
9-5	56240021	Spacer, Switch, Large	2
9-6	52170060	Cover, Switch	1
10	50140115	Panel, Internal (30")	1
10	50140116	Panel, Internal (36")	1
11	11010059	Control Board	1
12	12050028	Capacitor	1
13	12120070	Motor	1
14	50120069	Panel, Side (36")	2
15	50110128	Panel, Light (30")	1
15	50110129	Panel, Light (36")	1
16	50500142	Light Socket Assembly	2
17	Z0B-0020	Bulb, Halogen, GU-10, 50W	2
18	50200050	Filter, Baffle	2
19	05000094	Hardware Packet	1
19-1	15000004	Suction Cup	1
19-2	01070010	Screw, M4 x 8mm	4
19-3	01070006	Screw, M4 x 8mm	2
19-4	010700258	Screw, M4 x 1 1/2"	6