

24" Electric Cooktop

500 Series – Black Frameless NET5469SC



BOSCH
Invented for life



NET5469SC
Black

The 24" electric cooktop, sleek in design, features optimal temperature control and is ideal for kitchens with a smaller footprint.

Features & Benefits

PreciseSelect® offers 17 power levels for each cooking zone.

The flat stainless steel frame around the cooktop is perfect for integrating into existing countertop cutouts.

Panel lock feature locks the control panel to prevent accidental changes in settings.

2,200 W front right element for faster boil times.

Element Performance

Power of Front Left heating element	1,200 W
Power of Back Left heating element	2,000 W
Power of Back Right heating element	1,200 W
Power of Front Right heating element	2,200 W

Element Size

Dimension of Front Left heating element	6"
Dimension of Back Left heating element	7"
Dimension of Back Right heating element	6"
Dimension of Front Right heating element	8"

Technical Details

Watts	6,600 W
Circuit breaker	30 A
Volts	208-240 V
Frequency	60 Hz
Plug type	No plug
Energy source	Electric

Dimensions & Weight

Overall appliance dimensions (HxWxD)	4 1/3" x 23" x 20 1/5"
Required cutout size (HxWxD)	4 1/3" x 22" x 19 1/4"
Minimum distance from counter front	2 1/4"
Minimum distance from rear wall	2"
Net weight	20 lbs

Accessories – Optional



HEZ390210
8" AutoChef® pan



HEZ390220
9" AutoChef® pan



HEZ390230
10" AutoChef® pan



Accessories: To purchase Bosch accessories, cleaners & parts please visit www.bosch-home.com/us/store or call 1-800-944-2904 (Mon to Fri 5 am to 6 pm PST, Sat 6 am to 3 pm PST).

Notes: All height, width and depth dimensions are shown in inches. BSH reserves the absolute and unrestricted right to change product materials and specifications, at any time, without notice. Consult the product's installation instructions for final dimensional data and other details prior to making cutout.

Warranties: Please see Use & Care manual or Bosch website for statement of limited warranty.

For more information on our entire line of products, go to www.bosch-home.com/us or call 1-800-944-2904

© BSH Home Appliances Corporation. All rights reserved. Bosch is a registered trademark of Robert Bosch GmbH.

24" Electric Cooktop

500 Series – Black Frameless NET5469SC

Installation Details

Measurements in inches (mm)

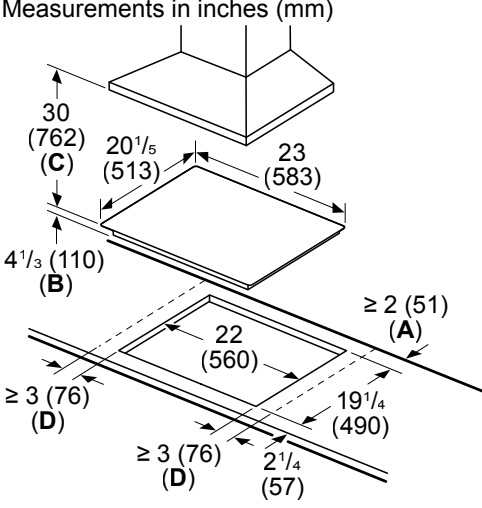

A: Min. distance from the cooktop cut-out to the wall

B: Max. recessed depth

C: Min. distance between the surface of the cooktop and the underside of the extractor hood
This distance can be smaller, check installation instructions of extractor hood

D: Min. distance from the cooktop cut-out to the side wall

Installation above Wall Ovens

Measurements in inches (mm)
24" (610 mm) Built-in oven – under electric cooktop

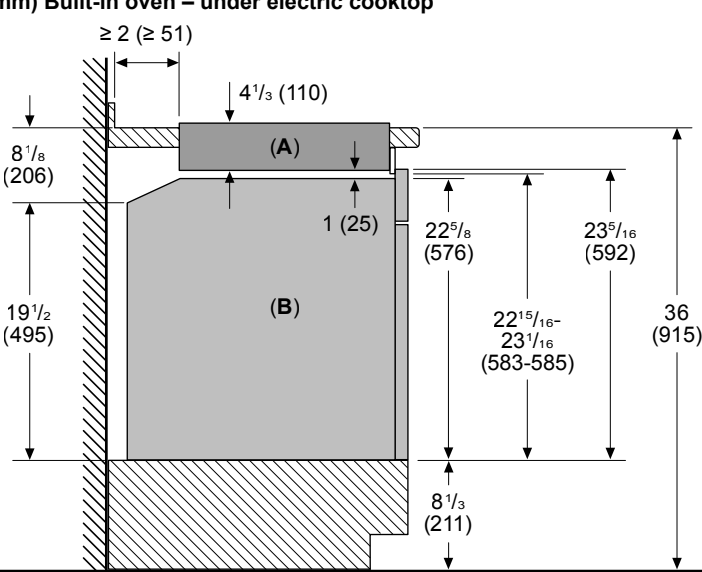

A: Cooktop
B: Built-in oven

Dimensions based on standard countertop height: 36" (914 mm) with 4 3/4" (121 mm) toe kick including base plate

The built-in oven can be installed below the cooktop as long as there is min. 1" (25 mm) of space between the bottom flat surface of the cooktop and the top of the oven

Please allow min. 2" (51 mm) from the countertop front edge to the edge of the cutout

Measurements in inches (mm)

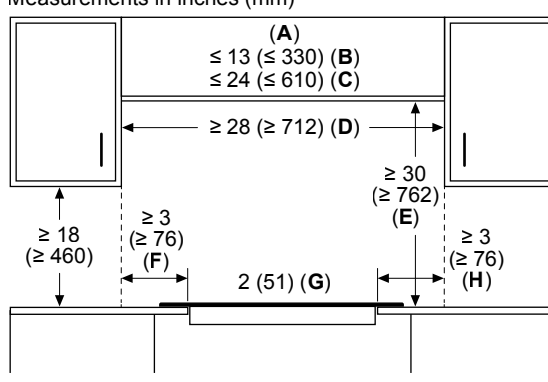

A: Depth from back wall

B: Cabinet

C: Hood depth

D: Combustible surface centered over cooktop

E: Above counter to combustable surface

F: Left side

G: Rear wall

H: Right side

Accessories: To purchase Bosch accessories, cleaners & parts please visit www.bosch-home.com/us/store or call 1-800-944-2904 (Mon to Fri 5 am to 6 pm PST, Sat 6 am to 3 pm PST).

Notes: All height, width and depth dimensions are shown in inches. BSH reserves the absolute and unrestricted right to change product materials and specifications, at any time, without notice. Consult the product's installation instructions for final dimensional data and other details prior to making cutout.

Warranties: Please see Use & Care manual or Bosch website for statement of limited warranty.

For more information on our entire line of products, go to www.bosch-home.com/us or call 1-800-944-2904

© BSH Home Appliances Corporation. All rights reserved. Bosch is a registered trademark of Robert Bosch GmbH.

24" Electric Cooktop

500 Series – Black Frameless NET5469SC



BOSCH
Invented for life



Installation Details

The junction box must be located within 3 feet of the cooktop connection. It should be easily accessible for service purposes.

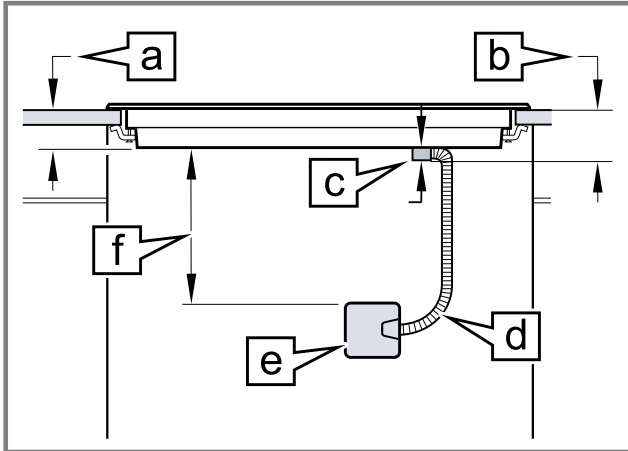

a	4.3" (110 mm)
b	5.3" (135 mm)
c	Fitting/conduit 1" (25 mm)
d	Conduit approx. 3 feet (900 mm)
e	Junction box
f	approx 12" (300 mm)

Accessories: To purchase Bosch accessories, cleaners & parts please visit www.bosch-home.com/us/store or call 1-800-944-2904 (Mon to Fri 5 am to 6 pm PST, Sat 6 am to 3 pm PST).

Notes: All height, width and depth dimensions are shown in inches. BSH reserves the absolute and unrestricted right to change product materials and specifications, at any time, without notice. Consult the product's installation instructions for final dimensional data and other details prior to making cutout.

Warranties: Please see Use & Care manual or Bosch website for statement of limited warranty.

For more information on our entire line of products, go to www.bosch-home.com/us or call 1-800-944-2904

© BSH Home Appliances Corporation. All rights reserved. Bosch is a registered trademark of Robert Bosch GmbH.