



Double Wall Oven

FPET3085PF

30" Electric



Product Dimensions

Height	50-7/16"
Width	30"
Depth	24-3/4"

More Easy-To-Use Features

One-Touch Keep Warm Setting
Just one touch of a button keeps food warm until everything — and everyone — is ready.

Steam Cleaning
A light oven cleaning that's chemical-free, odour-free, and fast.

Smudge-Proof™ Stainless Steel
Reduces fingerprints and smudges so it's easy to clean.

PowerPlus® Broil
Added power means you can broil food more evenly.

Even Baking Technology
Our Even Baking Technology ensures even baking every time.

Delay Start
Set your oven to begin cooking on your schedule. It can be programmed from one to 24 hours.

SpaceWise® Half Rack
Flexible rack system that adjusts to cook multiple dishes at once. Remove the half rack and you'll have extra height for tall dishes.

"My Favourite" Settings
Easily program your most used setting with the touch of a button.

Sabbath Mode (Star-K® Certified)

Available in:



Stainless
(F)

**Based on single rack cooking performance, not set temperature, using PowerPlus® Preheat.*

Signature Features



PowerPlus® Preheat
Preheat in less than six minutes.¹



PowerPlus® Convection
With our PowerPlus® Convection, the heat is evenly distributed for faster and more even baking and roasting — perfection in less time.



Effortless™ Convection
Takes the guesswork out of convection cooking — our oven automatically adjusts standard baking temperatures to convection temperatures for consistent results.

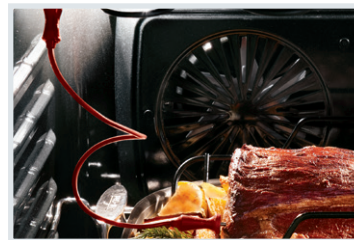

Effortless™ Temperature Probe
Take the guesswork out of cooking with the Effortless™ Temperature Probe that shows you the internal cooking temperature of your food. You can set the desired finished temperature and the oven alerts you when that temperature has been reached.

Features	
Oven Control/Timing System	Pro-Select®
Windows	Extra-Large with Pro-Tint Finish
Exterior Door Finish	Smudge-Proof™ Stainless Steel
Handle Design	Stainless Steel
Oven Cleaning System	Self-Clean w/ Steam Clean Option
Oven Controls	
Bake/Broil	Yes/Variable (400 - 550 °F)
Effortless™ Convection Conversion	Yes
Convection Bake/Broil/Roast	Yes/Yes/Yes
Oven Preheat	PowerPlus®
My Favourite	Yes
Slow Cook	Yes
Effortless™ Temperature Probe	Yes
Chicken Nugget Button	
Pizza Button	
Keep Warm	Yes
Add-a-Minute	
Delay Start	Yes
Self-Clean/Clean Options	Yes/2, 3, 4 Hours
Steam Clean	Yes
Delay Clean	Yes
Kitchen Timer/Timed Cook Option	Yes/Yes
Control Lock	Yes
Auto Oven Shut-Off	Yes
Oven Lock-Out	Yes
Upper Oven Features	
Capacity (Cu. Ft.)	4.6
Convection System	PowerPlus® Convection
Oven Light	2 Halogen
Hidden Bake Element	Yes
Rack Configuration	1 Heavy Duty, 1 SpaceWise® Half Rack, 1 Offset Rack
Baking System	Even Baking Technology
Broiling System	PowerPlus® Broil
Bake/Broil Element (Watts)	2,000 / 4,000
Lower Oven Features	
Capacity (Cu. Ft.)	4.6
Convection System	PowerPlus® Convection
Oven Light	2 Halogen
Hidden Bake Element	Yes
Rack Configuration	1 Heavy Duty, 1 SpaceWise® Half Rack, 1 Offset Rack
Baking System	Even Baking Technology
Broiling System	PowerPlus® Broil
Bake/Broil Element (Watts)	2,000 / 4,000
Optional Accessories	
3"-High Stainless Steel Bottom Trim	(F) PN # 318259707
10'-Long Armour red Power Cable	PN # 903056-9010
Certifications	
Sabbath Mode (Star-K® Certified)	Yes
Specifications	
Oven Interior (H x W x D)	17-1/2" x 24-1/8" x 18-3/4"
Power Supply Connection Location	Left Bottom Rear
Voltage Rating	240V / 208V / 60Hz
Connected Load (kW Rating) @ 240 / 208 Volts¹	9.5 / 7.1
Amps @ 240 / 208 Volts	39.6 / 34.1
Minimum Circuit Required (Amps)	40
Shipping Weight (Approx.)	280 Lbs.

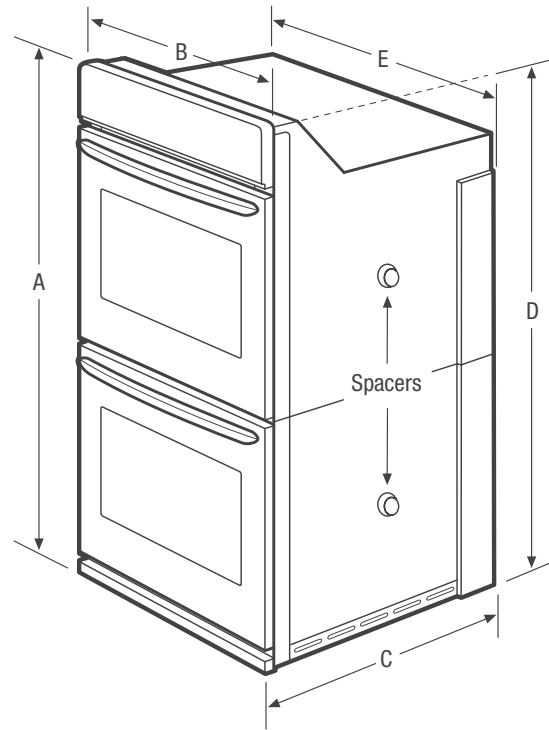

NOTE: For planning purposes only. Always consult local and national electric codes. Refer to Product Installation Guide for detailed installation instructions on the web at frigidaire.ca.



Product Dimensions	
A - Height	50-7/16"
B - Width	30"
C - Depth	24-3/4"
D - Height (Wrapper)	48-5/8"
E - Width (Wrapper)	28-1/4"
Depth with Door Open 90°	45-3/4"

Cutout Dimensions	
Height (Min.)/(Max.)	48-7/8" / 49-7/8"
Width (Min.)/(Max.)	28-1/2" / 29"
Depth (Min.)	23-1/2"

¹Single phase 3- or 4-wire cable, 120 / 240 or 120 / 208 Volt, 60 Hertz AC only electrical supply with ground required on separate circuit fused on both sides of line.

Accessories information available on the web at frigidaire.ca