

P/N: 8089336686

FRIGIDAIRE

FGID2479

This information is intended for use by persons having electrical and mechanical training and a level of knowledge of these subjects generally considered acceptable in the appliance repair trade. Electrolux Home Products, North America cannot be responsible, nor assume any liability, for injury or damage of any kind arising from the use of this Service Data Sheet.

Service Mode

After Cancel, press pad Heavy and Fast simultaneously for at least 4 seconds to access Service Mode.

LED Heavy, Led Normal and Led Fast blink to indicate that Service mode is accessed.

After accessed Service mode (Led Heavy, Led Normal and Led Fast blinking):

- Press pad Heavy to show the first alarm code.
 - Led Heavy blinks to indicate the machine is in Alarm Reading.
 - The first alarm code saved is shown in the display. For descriptions of alarm codes, please see Alarm Codes section.
- Press pad Heavy again to show the second alarm code.
- Press pad Heavy once more to show the third alarm code.
- Press pad Heavy the fourth time to move to Actuator Test. Press pad repeatedly will sequentially turn on one actuator at a time.
 - Led Heavy is turned off. led Normal blinks to indicate the machine is in Actuator Test.
 - The actuator number is shown in the display, see the following table for details.

Number of pad Heavy pressed	Actuator Number in display	Actuator
4	4	Regeneration Valve
5	5	Drain Pump
6	6	Inlet Valve
7	7	Heater
8	8	Wash pump
9	9	Dispenser
10	10	Dry Fan

- Press pad Heavy when actuator number 10 is activated, the machine will cycle back to Alarm reading and show the first alarm code saved.
- The mode can be exit by pressing the CANCEL button, or waiting 60 seconds after last button pressing.

LED Test/Delete Alarm Memory

After accessed Service mode (Led Heavy, Led Normal and Led Fast blinking):

- Press pad Normal to start this function.
 - All LEDs and display blinks 5 seconds on 1 second off.
 - Buzzer beeps 5 seconds and then off.
 - The alarm codes saved in memory are erased.
- The mode can be exit by pressing the CANCEL button, or waiting 60 seconds after last button pressing.

Functional Test cycle

After accessed Service mode (Led Heavy, Led Normal and Led Fast blinking):

- Press pad Fast to start the test cycle. The cycle will not start if door is opened.
 - LED Normal blinks all the way through the whole cycle, even if after the cycle is finished.
 - The test cycle runs as a normal wash cycle. It can be cancelled or run to its end.

Wiring Diagram

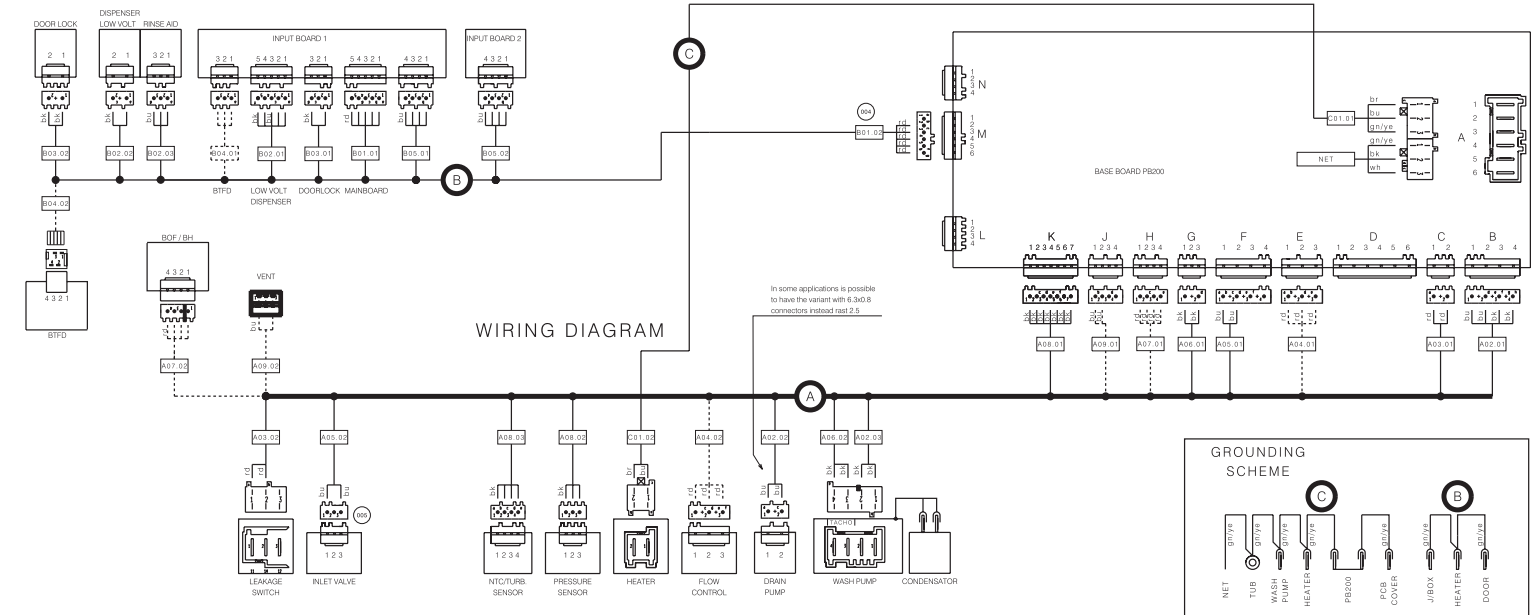

Wire-color

Code	Color
bk	black
br	brown
bu	blue
rd	red
gn/ye	green/yellow

Line-style

- dotted = Component is currently not in use (reserved)
- dashed = Component is optional

Connections included in WireHarnesses

WireHarness	Connection	WireEnd 01	WireEnd 02	WireEnd 03	WireEnd04	WireEnd 05
A	02	BaseBoard	DrainPump	WashPump		
A	03	BaseBoard	LeakageSwitch			
A	04	BaseBoard	FlowControl			
A	05	BaseBoard	InletValve			
A	06	BaseBoard	WashPumpTacho			
A	07	BaseBoard	BOF			
A	08	BaseBoard	PressureSensor	NTC/Turb Sensor		
A	09	BaseBoard	VENT			
B	01	UserInterface 1	BaseBoard			
B	02	UserInterface 1	Dispenser	RinseAid		
B	03	UserInterface 1	Door lock			
B	04	UserInterface 1	BTFD			
B	05	UserInterface 1	UserInterface 2			
C	01	BaseBoard	Heater			

Cycle Selection Options

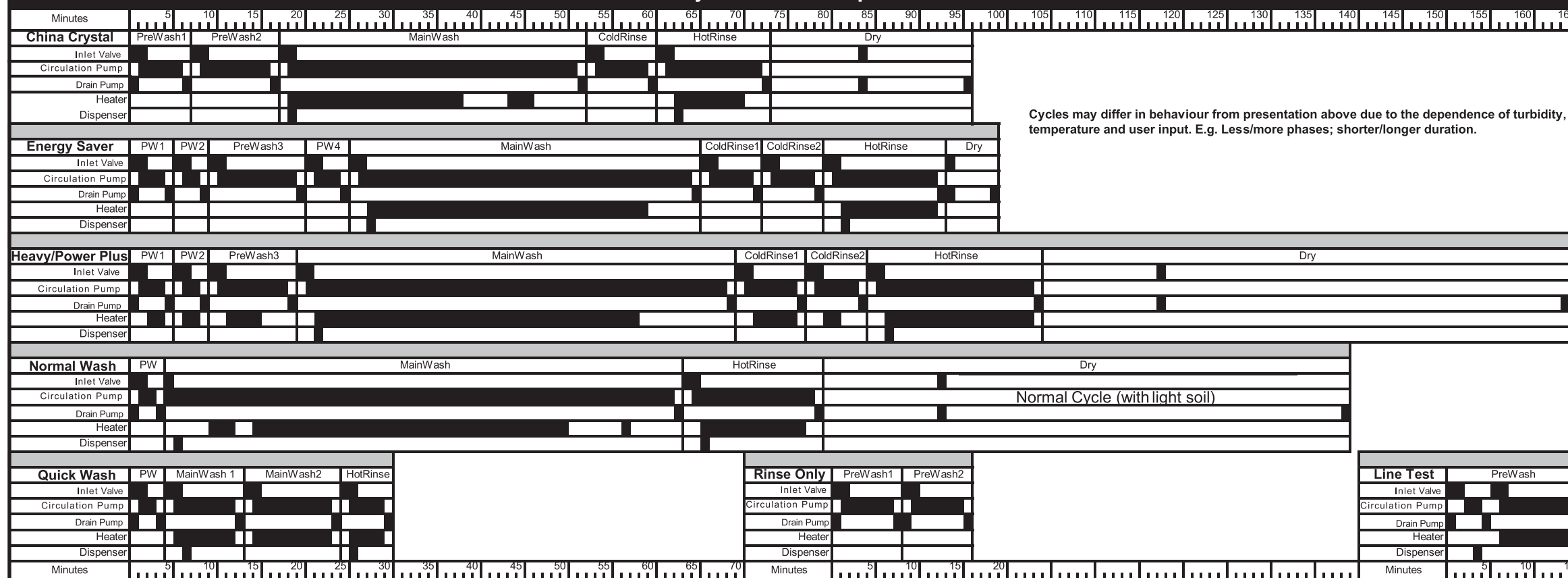

Cycles may differ in behaviour from presentation above due to the dependence of turbidity, temperature and user input. E.g. Less/more phases; shorter/longer duration.

Exploded View of Wash System

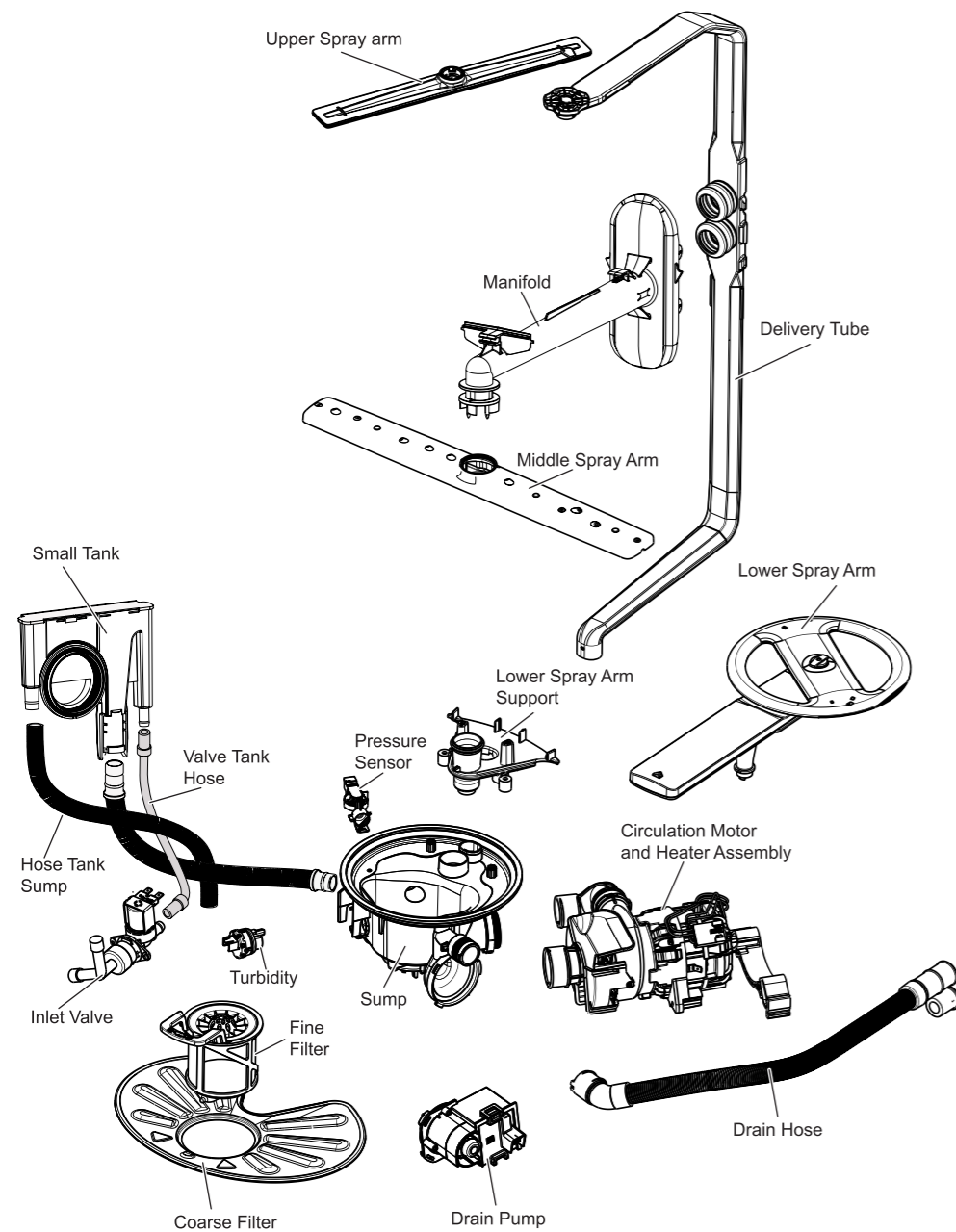

Tub Gasket

The door gasket is pressed into the tub channel for an interference fit. To install the gasket:

1. Press the gasket across the header using your hands.
2. Press the gasket while stretching around the corners .

NOTE: There should be no wrinkles or puckers in the corners.

3. Place the gasket end at the bottom and then press the gasket in from the bottom up.

Detergent and Rinse Aid Dispenser

The detergent and rinse aid dispenser is a one piece component consisting of a molded detergent cup and a built-in rinse aid dispenser.

The detergent cup has a spring loaded cover and the rinse aid dispenser has a cover.

Liquid rinse aid is added to the dispenser up to the fill line indicator. The amount of rinse aid released can be adjusted from 1, being the least amount, to 6, being the greatest amount.

To replace dispenser:

- shut off electricity to dishwasher,
- remove outer door panel assembly,
- disconnect wiring to the actuator,
- remove the six screws,
- remove the dispenser,
- replace and reinstall screws,
- rewire actuator.

Display Codes (LED)

LED status indicators located in the center of the Keypad

CLEANThe LED labeled "CLEAN" will lit when the cycle is complete.

SANITIZED.....The LED labeled "SANITIZE will lit when the sanitization criteria has been met. If the sanitization criteria is not archived, the LED will not display

Operation

Starting a Cycle Open door,select the cycle and options: then press the "START-cancel" pad. The LED over the selected cycle pad will then flash. Close the door and the cycle will begin.

Delay Start Open door,select the cycle and options; then press the "DELAY" pad. Each press of the pad will increase the delay time by 1 hour (1 to 24 hours).

Cancelling a cycle Open door, select the "START-cancel" pad until a tone is heard.

Selecting a new cycle or option Open door, select the desired cycle and options; then press the "START-cancel" pad and close the door. The cycle will begin.

Locking Controls Open door and hold down the "DELAY" pad for 5 seconds. The status window will display "loc"and the pads will be unresponsive. To unlock the control hold the "DELAY" pad down for 5 seconds until "loc" goes out. Normal function will resume.

Alarm Codes/Description

Code family	Description
i10	Water Tap Closed
i20	Draining Problem
i30	Aqua Control
i40	Analogue pressure sensor problem
i50	Washing Motor Problem
i60	Heating Element Problem
i70	Thermistor problem
i80	Auto Door Opener
i90	Configuration Problem
iB0	Sensor Problem
iC0	Communication problem
iD0	Tacho problem
iE0	Flow controller problem
iF0	Water level problem

Trouble Shooting Tips

⚠ WARNING

Personal Injury Hazard

Always disconnect the dishwasher from the electrical power source before adjusting or replacing components.

Symptom	Check the Following	Remedy
Dishwasher will not operate when turned on.	<ol style="list-style-type: none"> 1. Fuse (blown or tripped). 2. 120 VAC supply wiring connection faulty. 3. Electronic control board defective. 4. No 12 VAC power to control. 5. Motor (inoperative). 6. Door switch (open contacts). 7. Door latch not making contact with door switch. 8. Touch pad circuit defective. 9. No indicator lamps illuminate when START or OPTIONS are pressed. 	<ol style="list-style-type: none"> 1. Replace fuse or reset breaker. 2. Repair or replace wire fasteners at dishwasher junction box. 3. Replace control board. 4. Replace control board. 5. Replace motor/impeller assembly. 6. Replace latch assembly. 7. Replace latch assembly. 8. Replace console assembly. 9. Replace console assembly.
Motor hums but will not start or run.	<ol style="list-style-type: none"> 1. Motor (bad bearings). 2. Motor stuck due to prolonged non-use. 	<ol style="list-style-type: none"> 1. Replace motor assembly. 2. Rotate motor impeller.
Motor trips out on internal thermal overload protector.	<ol style="list-style-type: none"> 1. Improper voltage. 2. Motor windings shorted. 3. Glass or foreign items in pump. 	<ol style="list-style-type: none"> 1. Check voltage. 2. Replace motor/impeller assembly. 3. Clean and clear blockage.
Dishwasher runs but will not heat.	<ol style="list-style-type: none"> 1. Heater element (open). 2. Electronic control board defective. 3. Wiring or terminal defective. 4. Hi-Limit thermostat defective. 	<ol style="list-style-type: none"> 1. Replace heater element. 2. Replace control board. 3. Repair or replace. 4. Replace thermostat.
Detergent cover will not latch or open.	<ol style="list-style-type: none"> 1. Latch mechanism defective. 2. Electronic control board defective. 3. Wiring or terminal defective. 4. Broken spring(s). 5. Defective actuator. 	<ol style="list-style-type: none"> 1. Replace dispenser. 2. Replace control board. 3. Repair or replace. 4. Replace dispenser. 5. Replace dispenser.
Dishwasher will not pump out.	<ol style="list-style-type: none"> 1. Drain restricted. 2. Electronic control board defective. 3. Defective drain pump. 4. Blocked impeller. 5. Open windings. 6. Wiring or terminal defective. 7. Defective Drain Valve. 	<ol style="list-style-type: none"> 1. Clear restrictions. 2. Replace control board. 3. Replace pump. 4. Check for blockage, clear. 5. Replace pump assembly. 6. Repair or replace. 7. Repair or replace.
Dishwasher will not fill with water.	<ol style="list-style-type: none"> 1. Water supply turned off. 2. Defective water inlet fill valve. 3. Check fill valve screen for obstructions. 4. Defective float switch. 5. Electronic control board defective. 6. Wiring or terminal defective. 7. Float stuck in "UP" position. 	<ol style="list-style-type: none"> 1. Turn water supply on. 2. Replace water inlet fill valve. 3. Disassemble and clean screen. 4. Repair or replace. 5. Replace control board. 6. Repair or replace. 7. Clean or replace float.
Dishwasher water siphons out.	<ol style="list-style-type: none"> 1. Drain hose (high) loop too low. 2. Drain line connected to a floor drain not vented. 3. Drain valve or pump stuck open. 	<ol style="list-style-type: none"> 1. Repair to proper 32-inch minimum height. 2. Install air gap at counter top. 3. Repair or replace.
Detergent left in dispenser.	<ol style="list-style-type: none"> 1. Detergent allowed to stand too long in dispenser. 2. Dispenser wet when detergent was added. 3. Detergent cover held closed or blocked by large dishes. 4. Improper incoming water temperature to properly dissolve detergent. 5. Spray arm blocked. 6. Is water getting into unit. 	<ol style="list-style-type: none"> 1. Instruct customer/user. 2. Instruct customer/user. 3. Instruct customer/user on proper loading of dishes. 4. Incoming water temperature of 120°F is required to properly dissolve dishwashing detergents. 5. Instruct customer/user. 6. Check fill valve repair or replace.

Note: See "Detergent cover will not latch or open."

Pump Assembly

The circulation pump is driven by a permanent split-capacitor asynchronous induction motor. When looking into the inlet hose, the impeller rotates in the counter-clockwise direction when 120V 60 Hz AC voltage is applied. The motor drives the pump, supplying 100% filtered water at a rate of approximately 17 GPM to all three spray arms at once. At this full-wave mains voltage and flow-rate, the motor speed is approximately 2900 rpm.

Draining is accomplished by using a smaller, separate, synchronous drain pump motor mounted to the sump. The drain pump is connected to the sump directly.

A rubber check valve flap is inserted at the

discharge end of the drain outlet pipe, which is integrated on the sump.

A raised drain hose loop section is routed on the side of the unit to help prevent/limit back flow out of the dishwasher. No additional such loops are required.

The main circulation pump is removed by disconnecting both attached clamps and hoses, disconnecting the wiring harness to the pump assembly, un-strapping the pump out of the rubber mount in the basement, and disconnecting the running capacitor. Wire harness connections include 2 earth tabs, motor connector, heater connector and the 2 terminals of the running capacitor.

Product Specifications

Electrical

Rating 120 Volts, 60Hz
 Separate Circuit..15 amp min.- 20 amp max.
 Motor (Amps)0.8
 Heater Wattage 850
 Total Amps (load rated) 13.0
 Water Temps controlled ±5°F
 To assure success have outer door in place
 TempAssure (cycle dependent)
 Main Wash: 140°F
 Final Wash: 140°F
 Hi-TempAssure: 140°F Wash/149°F Final Rinse
 SanitizeAssure: 140°F Wash/156°F Final Rinse
 Hi-Limit Thermostat 200°F (93°C)

Water Supply

Suggested minimum incoming water temperature 120°F (49°C)
 Pressure (PSI) min./max. 20/90
 Connection (GHT).....3/4" 11.5NH
 Consumption (Normal Cycle)
 2.9 - 7.3 U.S. gal., 11.0 - 27.7 liters
 Water valve flow rate (U.S. GPM) 0.66
 Water recirculation rate (U.S. GPM)
 approx. 17 (@2900rpm)
 Water fill time 104 sec.