

Apartment Refrigerators

FFPT12F3M M/W/V¹/B

Frost Free
12 Cu. Ft. Top Mount



Product Dimensions

A - Height	59-7/8"
B - Width	23-5/8"
C - Depth (Including Door)	28-3/4"
D - Depth with Door Opened 90°	50-5/8"

More Easy-To-Use Features

Ready-Select® Controls

Store-More™ Built-In Can Dispenser

Convenient in-door can storage.

Bright Lighting

Our bright lighting makes it easy to see what's inside.

Square Door Design

Color-Coordinated Door Handle (Recessed)

Color-Coordinated Smooth Cabinet Finish

Color-Coordinated Door Hinge Covers

Reversible Door-Swing Option

Door can be installed to open left or right based on your needs.

Available in:



Silver Mist (M)

White (W/V)

Black (B)

¹Left-Swing Door.

Signature Features

Store-More™ Freezer

Easy-to-access freezer includes a shelf and door rack.

Store-More™ Clear Crisper Drawers

Keep your fruits and vegetables fresh in our crisper drawers.

SpaceWise® Adjustable Glass Shelves

Easily adjust shelves up and down to create more space for taller items.

Store-More™ Door Bins

Door bins provide ample storage.

Features	
Cubic Feet (Cu.Ft.)	12.0
Defrost	Frost Free
Exterior	
Door Color	Color-Coordinated
Cabinet Color	Color-Coordinated
Door Handle	Integrated
Door Stops	Yes
Reversible Door	Yes (M/W/B)
Interior	
Controls	Ready-Select*
Lighting	Bright
Refrigerator Shelves	2 SpaceWise® Adjustable Glass
Store-More™ Crisper Drawers	2 Clear
Door Bins	2 Half-Width Clear
Door Racks	2 Full-Width Clear
Tall Bottle Storage	Yes
Can Rack	6-Can Capacity
Freezer Racks	2 Full-Width Clear
Freezer Shelves	1 SpaceWise® Adjustable Wire
Cabinet Liner	White
Certifications	
ENERGY STAR®	
Specifications	
Total Capacity (Cu.Ft.)	12.0
Refrigerator Capacity (Cu.Ft.)	9.0
Freezer Capacity (Cu.Ft.)	3.0
Power Supply Connection Location	Right Bottom Rear
Voltage Rating	115V/60Hz/15 or 20A
Minimum Circuit Required (Amps)	15
Shipping Weight (Approx.)	150 Lbs.
Installation Type	Freestanding

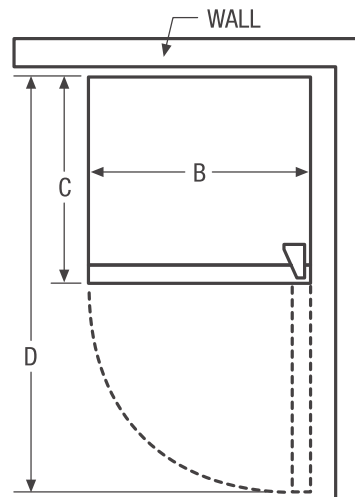
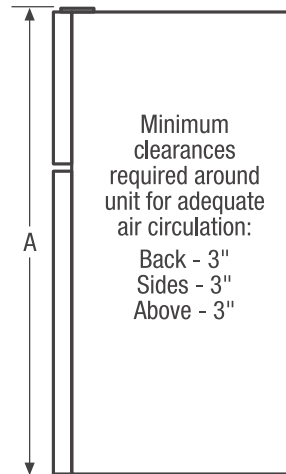

NOTE: For planning purposes only. Always consult local and national electric codes. Refer to Product Installation Guide for detailed installation instructions on the web at frigidaire.com.



Product Dimensions	
A - Height	59-7/8"
B - Width	23-5/8"
C - Depth (Incl. Door)	28-3/4"
D - Depth with Door Open 90°	50-5/8"

Accessories information available on the web at frigidaire.com

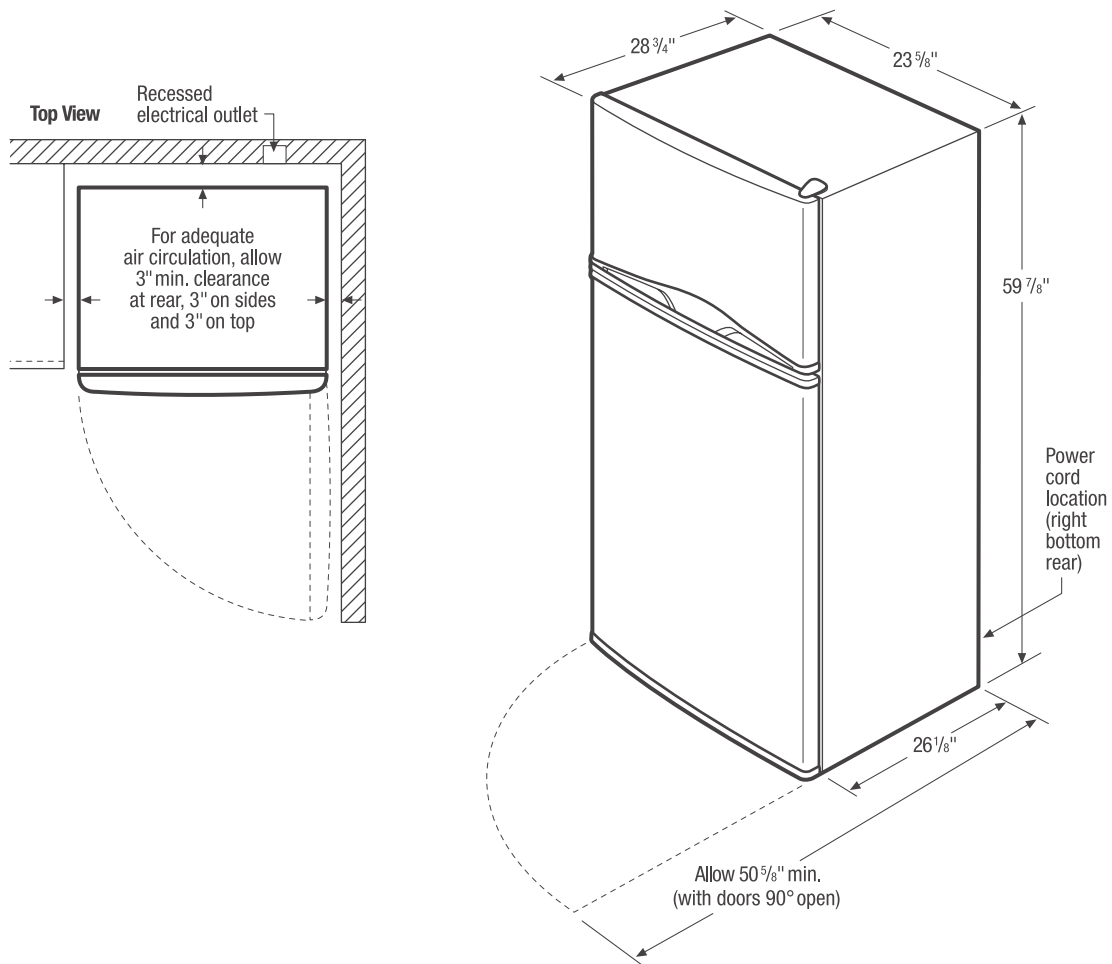

Apartment Refrigerator Specifications

- Product Shipping Weight (approx.) - 150 Lbs.
- Voltage Rating - 115V/60 Hz/15 or 20 Amps
- Always consult local and national electric codes.
- For adequate air circulation, allow 3" minimum clearance at rear, 3" on sides and 3" on top.
- Locate where surrounding air temperature will not exceed 110° F or drop below 10° F, to ensure optimum performance.

- All bottom corners of unit MUST rest firmly on solid level surface of hard material, same height as flooring. Surface must be strong and stable enough to support unit when fully loaded.
- Equipped with adjustable leveling legs to ensure unit is level, which is required in order to function properly.

Note: For planning purposes only. Refer to Product Installation Guide on the web at frigidaire.com for detailed instructions.