



OWNER'S MANUAL

Double-Drawer Built-In Refrigerator

Introduction

Your new Monogram double-drawer refrigerator makes an eloquent statement of style, convenience and kitchen planning flexibility. Whether you chose it for its purity of design or the assiduous attention to detail, you will find that your Monogram double-drawer refrigerator's superior blend of form and function will delight you for years to come.

The information on the following pages will help you operate and maintain your double-drawer refrigerator properly.

If you have any other questions, visit our Website at: **monogram.com**

Contents

Care and Cleaning	12	Repair Service.....	3, 19
Consumer Services	18	Safety Instructions.....	4
Controls and Features.....	8	Top Canopy Removal.....	15
Model and Serial Numbers.....	2	Warranty	17
Problem Solver.....	16		

Before using your double-drawer refrigerator

Read this manual carefully. It is intended to help you operate and maintain your new double-drawer refrigerator properly.

Keep it handy for answers to your questions.

If you don't understand something or need more help, there is a list of toll-free consumer service numbers included in the back section of this manual.

OR

Visit our Website at: **monogram.com**

Write down the model & serial numbers

You will find them on a label on the ceiling inside the double-drawer refrigerator.

Please write these numbers here:

Model Number

Serial Number

Use these numbers in any correspondence or service calls concerning your double-drawer refrigerator.

If you received a damaged appliance

The warranty does not cover damage caused after delivery.

Immediately contact the dealer (or builder) that sold you the double-drawer refrigerator.

Save time & money

Before you request service, check the Problem Solver in the back of this manual.

It lists causes of minor operating problems that you can correct yourself.

Remove packaging

Before using, be sure all packing materials and tape have been removed.

To assure no damage is done to the finish of the product, the safest way to remove the adhesive left from packaging tape on new

appliances is an application of household liquid detergent. Apply with a soft cloth and allow to soak. Wipe dry and then apply an appliance polish to thoroughly clean and protect the surface.

If you need service

To obtain service, see the Consumer Services page in the back of this manual.

We are proud of our service and want you to be pleased. If for some reason you are not happy with the service you receive, here are steps to follow for further help.

For customers in the USA:

FIRST, contact the people who serviced your appliance. Explain why you are not pleased. In most cases, this will solve the problem.

NEXT, if you are still not pleased, write all the details—including your phone number—to:

Manager, Customer Relations
Monogram
GE Appliance Park
Louisville, KY 40225

For customers in Canada:

FIRST, contact the people who serviced your appliance. Explain why you are not pleased. In most cases, this will solve the problem.

NEXT, if you are still not pleased, write all the details—including your phone number to:

Manager, Consumer Relations
Mabe Canada Inc.
1 Factory Lane, Suite 310
Moncton, N.B. E1C 9M3

After installation is completed

- Promptly inspect your new Monogram double-drawer refrigerator. If it has been damaged, contact the Installer or Dealer immediately.
- This double-drawer refrigerator must be properly leveled to ensure correct drawer alignment and drawer closure. Contact the Installer if the unit is not level.
- The unit should be centered in the opening. The front face of the drawer will be flush with adjacent cabinetry. Contact the installer if clearance is not correct.

- Test the drawer. Carefully open and close the drawer. The drawer should not rub or catch on adjacent cabinetry. Notify the installer if the drawer makes contact with cabinetry.

Please Contact the Installer or Dealer if you experience any of these problems.

Your custom panel (ZIDI240 model only) double-drawer refrigerator is shipped with two toekicks, a stainless steel and a black toekick. For shipping purposes, one of the toekicks will be secured to the back or on the inside of the unit, and the second will be installed on the unit. Keep the unused toekick and other unused or removed parts for possible future use.

IMPORTANT SAFETY INSTRUCTIONS

Double-Drawer Refrigerator

⚠ WARNING To reduce the risk of fire, explosion, electric shock, or injury when using your refrigerator/freezer, follow these basic safety precautions:

- Double-drawer refrigerators are designed to be built-in only. They cannot be used free-standing.
- Use this appliance only for its intended purpose as described in this Owner's Manual.
- This refrigerator must be properly installed and located in accordance with the Installation Instructions before it is used.
- Unplug the refrigerator/freezer before making repairs, or cleaning.
NOTE: Power to the refrigerator/freezer cannot be disconnected by any setting on the control panel.
NOTE: Repairs must be performed by a qualified Service Professional.
- Replace all parts and panels before operating.
- Do not use an extension cord.
- Do not store or use gasoline or other flammable vapors and liquids in the vicinity of this or any other appliance.
- Do not store explosive substances such as aerosol cans with a flammable propellant in this appliance.
- To prevent suffocation and entrapment hazards to children, remove the fresh food and freezer doors from any refrigerator/freezer before disposing of it or discontinuing its use.
- To avoid serious injury or death, children should not stand on, or play in or with the appliance.
- Children and persons with reduced physical, sensory or mental capabilities or lack of experience and knowledge can use this appliance only if they are supervised or have been given instructions on safe use and understand the hazards involved.
- This appliance is intended to be used in household and similar applications such as: staff kitchen areas in shops, offices and other working environments; farm houses; by clients in hotels, motels, bed & breakfast and other residential environments; catering and similar non-retail applications.

⚠ CAUTION To reduce the risk of injury when using your refrigerator/freezer, follow these basic safety precautions.

- Do not clean glass shelves or covers with warm water when they are cold. Glass shelves and covers may break if exposed to sudden temperature changes or impact, such as bumping or dropping. Tempered glass is designed to shatter into many small pieces if it breaks.
- Keep fingers out of the "pinch point" areas; clearances between the doors and between the doors and cabinet are necessarily small. Be careful closing doors when children are in the area.
- Do not refreeze frozen foods which have thawed completely.

READ AND SAVE THESE INSTRUCTIONS

IMPORTANT SAFETY INSTRUCTIONS

Double-Drawer Refrigerator

CONNECTING ELECTRICITY

⚠ WARNING **Electrical Shock Hazard.**

Plug into a grounded 3-prong outlet
Do not remove the ground prong
Do not use an adapter
Do not use an extension cord.
Failure to follow these instructions can result in death, fire, or electrical shock.

Do not, under any circumstances, cut or remove the third (ground) prong from the power cord. For personal safety, this appliance must be properly grounded.

The power cord of this appliance is equipped with a 3-prong (grounding) plug which mates with a standard 3-prong (grounding) wall outlet to minimize the possibility of electric shock hazard from this appliance.

Have the wall outlet and circuit checked by a qualified electrician to make sure the outlet is properly grounded.

Where a standard 2-prong wall outlet is encountered, it is your personal responsibility and obligation to have it replaced with a properly grounded 3-prong wall outlet. Do not use an adapter.

Use of a GFI (Ground Fault Interrupter) is not recommended for the fresh-food refrigerator.

A 115 Volt AC, 60 Hz, 15- or 20-amp fused, grounded electrical supply is required. This provides the best performance and also prevents overloading house wiring circuits which could cause a fire hazard from overheated wires.

Never unplug your refrigerator by pulling on the power cord. Always grip plug firmly and pull straight out from the outlet.

Immediately discontinue use of a damaged supply cord. If the supply cord is damaged, it must be replaced by a qualified service professional with an authorized service part from the manufacturer.

When moving the refrigerator away from the wall, be careful not to roll over or damage the power cord.

DO NOT USE AN ADAPTER PLUG TO CONNECT THE FRESH-FOOD REFRIGERATOR TO A 2-PRONG OUTLET.

PROPER DISPOSAL OF YOUR OLD REFRIGERATOR

⚠ WARNING **SUFFOCATION AND ENTRAPMENT HAZARD**

Failure to follow these disposal instructions can result in death or serious injury

IMPORTANT: Child entrapment and suffocation are not problems of the past. Junked or abandoned refrigerators are still dangerous even if they will sit for “just a few days.” If you are getting rid of your old refrigerator, please follow the instructions below to help prevent accidents.

Before You Throw Away Your Old Appliance

- Take off the fresh food and freezer doors.
- Leave the shelves in place so that children may not easily climb inside.

Refrigerant and Foam Disposal:

Dispose of appliance in accordance with Federal and Local Regulations. Flammable insulation material used requires special disposal procedures. Contact your local authorities for the environmentally safe disposal of your appliance.

READ AND SAVE THESE INSTRUCTIONS

IMPORTANTES INSTRUCTIONS DE SÉCURITÉ

⚠ AVERTISSEMENT Pour réduire le risque d'incendie, d'explosion, de choc électrique ou de blessures lorsque vous utilisez votre réfrigérateur, veuillez suivre ces consignes de sécurité :

- Les réfrigérateurs à deux tiroirs sont conçus pour être encastrés uniquement. Ils ne peuvent pas être séparés.
- N'utilisez l'appareil que pour son usage prévu, comme décrit dans le présent manuel.
- Ce réfrigérateur doit être correctement installé conformément aux Consignes d'Installation avant toute utilisation.
- Débranchez le réfrigérateur avant d'effectuer une réparation, de remplacer une ampoule ou de le nettoyer.
Remarque : L'alimentation du réfrigérateur ne peut être déconnectée par aucune des fonctions sur le panneau de commande.
Remarque : Les réparations doivent être effectuées par un professionnel qualifié.
- Remettez toutes les pièces et panneaux en place avant d'utiliser l'appareil.
- N'utilisez pas un cordon de rallonge.
- Abstenez-vous d'entreposer ou d'utiliser de l'essence ou d'autres vapeurs et liquides inflammables aux alentours de cet électroménager ou d'autres appareils.
- N'entreposez pas dans cet électroménager des substances explosives telles que des bombes aérosols qui contiennent un gaz propulseur.
- Pour éviter les risques d'asphyxie et d'enfermement pour les enfants. Démontez les portes du congélateur et du compartiment de réfrigération avant de le mettre au rebut ou d'interrompre son utilisation.
- Ne laissez pas les enfants grimper, se mettre debout ou se suspendre aux poignées de portes dans le réfrigérateur ou aux clayettes du réfrigérateur. Ils pourraient se blesser gravement.
- Les enfants et les personnes dont les capacités sont réduites sur le plan physique, sensoriel ou mental, ou qui manquent d'expérience ou de connaissances, peuvent utiliser cet électroménager seulement si elles sont surveillées ou ont reçues des consignes de sécurité sur son usage et les risques y sont associés.
- Cet électroménager est conçu pour une utilisation domestique et applications similaires : salle du personnel dans une usine, un bureau ou d'autres lieux de travail; maison de ferme; clients dans un hôtel, un motel, un gîte touristique et d'autres lieux résidentiels; approvisionnement et applications similaires non reliées au commerce de détail.

⚠ ATTENTION Pour réduire le risque de blessures lorsque vous utilisez votre réfrigérateur, veuillez suivre ces consignes de sécurité.

- Ne nettoyez pas les clayettes ou les couvercles en verre avec de l'eau tiède quand ceux-ci sont froids. Les clayettes et couvercles en verre peuvent se casser s'ils sont exposés à des changements soudains de température ou si vous les cognez ou les faites tomber. Le verre trempé est conçu pour se briser en petits morceaux en cas de casse
- Éloignez les doigts des parties du congélateur où l'on peut facilement se pincer : les espaces entre les portes, et entre les portes et les placards sont toujours étroits. Soyez prudent lorsque vous fermez les portes en présence d'enfants.
- Ne recongelez pas les aliments surgelés qui ont complètement dégelé.

LEA Y GUARDE ESTAS INSTRUCCIONES

IMPORTANTES INSTRUCTIONS DE SÉCURITÉ

BRANCHEMENTS ÉLECTRIQUES

⚠ AVERTISSEMENT **RISQUE DE CHOC ÉLECTRIQUE**

Branchez l'appareil dans une prise triple avec terre.

Ne retirez pas la broche de terre.

N'utilisez pas d'adaptateur.

N'utilisez pas un cordon de rallonge.

Le non-respect de ces instructions peut entraîner des risques d'incendies, des chocs électriques ou la mort.

Ne coupez pas ou n'enlevez pas, sous aucun prétexte, la troisième broche de mise à la terre du cordon d'alimentation. Pour des raisons de sécurité, cet appareil doit être correctement mis à la terre.

Le cordon d'alimentation de cet appareil est équipé d'une fiche à trois broches (pour une mise à la terre) qui s'adapte à la prise de courant standard à 3 broches (pour une mise à la terre) pour minimiser les risques de chocs électriques par cet appareil.

Faites vérifier la prise murale et le circuit électrique par un électricien qualifié pour s'assurer que le système est correctement mis à la terre.

Dans le cas d'une prise biphasée, l'installateur a la responsabilité et l'obligation de la remplacer par une prise triphasée correctement mise à la terre. N'utilisez pas d'adaptateur.

L'utilisation d'un disjoncteur différentiel de fuite à la terre (DDFT) n'est pas recommandée pour le réfrigérateur.

Une alimentation électrique à 115 volts CA, 60 Hz, avec un fusible de 15 ou 20 ampères et une mise à la terre est nécessaire. Ceci permet d'obtenir un meilleur rendement et évite de surcharger les circuits électriques du domicile qui risque d'occasionner un incendie en surchauffant.

Ne débranchez jamais le réfrigérateur en tirant sur le cordon d'alimentation. Prenez toujours fermement la fiche en main et tirez pour la sortir de la prise.

Cessez immédiatement d'utiliser un cordon électrique endommagé. Si le cordon électrique est endommagé, son remplacement doit être effectué par un technicien en réparation qualifié au moyen d'un cordon de rechange autorisé par le fabricant.

Lorsque vous éloignez votre réfrigérateur du mur, faites attention à ne pas le faire rouler sur le cordon d'alimentation afin de ne pas l'endommager.

N'UTILISEZ JAMAIS UNE PRISE À ADAPTATEUR POUR LE RÉFRIGÉRATEUR POUR DENRÉES FRAÎCHES À UNE PRISE BIPOLAIRE.

MISE AU REBUT APPROPRIÉE DE VOTRE ANCIEN appareil

⚠ AVERTISSEMENT **RISQUE DE SUFFOQUER OU D'Y ÊTRE EMPRISONNÉ**

Le non-respect de ces instructions d'élimination peut entraîner la mort ou des blessures graves.

IMPORTANT: Les enfants pris au piège ou morts d'asphyxie sont toujours d'actualité. Les réfrigérateurs et congélateurs abandonnés sont toujours aussi dangereux, même si on n'attend que «quelques jours» pour s'en débarrasser. Si vous ne gardez pas votre ancien réfrigérateur ou congélateur, veuillez suivre les directives ci-dessous afin de prévenir les accidents.

Avant de vous débarrasser de votre ancien appareil :

- Démontez les portes du compartiment de réfrigération et du compartiment de congélation.
- Laissez les clayettes en place afin d'empêcher les enfants de grimper à l'intérieur.

Mise au rebut des produits réfrigérants et en mousse

Mettez l'électroménager au rebut conformément à la réglementation fédérale et locale. Les matières isolantes inflammables utilisées exigent des procédures de mise au rebut spéciales. Communiquez avec les autorités locales pour connaître la façon de mettre votre électroménager au rebut qui soit respectueuse de l'environnement.

LEA Y GUARDE ESTAS INSTRUCCIONES

Controls and Features

Double-Drawer Refrigerator

Temperature control

The temperature display shows the actual temperature of the double-drawer refrigerator. The actual temperature may vary slightly from the set temperature based on factors such as drawer opening, amount of food and room temperature.

To change the temperature setting, press the + or - pads until you reach the desired set temperature. After 5 seconds, the display will return to the actual temperature.

Allow 12–24 hours for the double-drawer refrigerator to reach the temperature you have set.

Temperature Settings

Minimum: 34°F (1.1°C)

Maximum: 45°F (7.2°C)

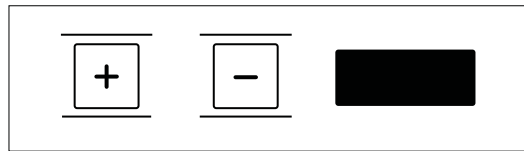

Child control lockout

This child control lockout feature prevents unwanted changes to your temperature settings.

After the desired temperature is set, the temperature can be locked. To lock, press both the + and – pads at the same time for five seconds. To unlock, press both + and – pads for five seconds.

Unit ON/OFF

This pad stops cooling in the double-drawer refrigerator, turns off the temperature controls and removes power to the light circuit.

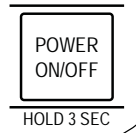

Press this pad for a minimum of 3 seconds to turn the double-drawer refrigerator on or off or unplug the unit for long vacations or absences, or when cleaning the unit or changing the light bulb.

Interior fan

The interior fan located in the rear wall of the double-drawer refrigerator may run for extended periods due to usage and ambient temperature. This is normal. See Normal operating sounds in Problem Solver section for additional information about the fans. The interior fan will turn off when the drawer is opened.

Glass divider

The top drawer has a moveable, tempered glass divider for separating and organizing foods. The divider can be placed in one of two locations.

To remove the divider, lift up until divider clears the rear and front retaining slots.

To replace the divider, slide into one of the divider locations.

The glass divider is dishwasher safe, top rack only.

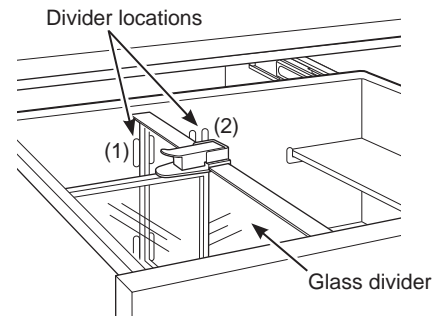

Snugger

The snugger attached to the glass divider helps prevent tipping, spilling or sliding of small items when the top drawer is opened. Lift the lock down lever near the top of the snugger, then move it to fit your needs. Press the lever down to lock the snugger in place. The snugger is dishwasher safe, top rack only.

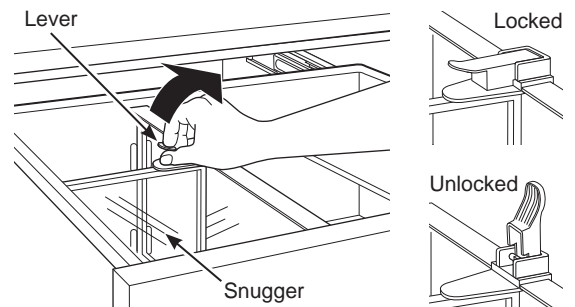

Assembly instructions

To remove:

1. Lift the glass divider assembly out of the drawer by grasping the glass divider and snugger where the lever is located. Sit the assembly on a sturdy surface.
2. Lift the lever.
3. Slide the snugger off the glass divider.
4. Remove the lever from the snugger by lifting the lever up and sliding it down and out of the assembly.

NOTE: The glass divider, snugger and lever can be cleaned on the top rack of a dishwasher.

To replace or relocate:

1. Reassemble lever into snugger by sliding the lever up into place.
2. Slide glass divider into the snugger. The lever must be installed before sliding the divider into the snugger.
3. Put the glass divider assembly in the desired divider location in the top drawer.

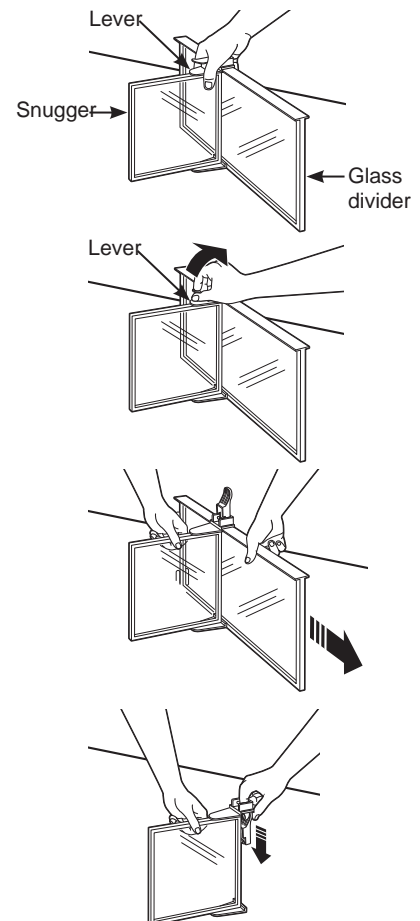

Shelf

The top drawer features a shelf that can fold down for storage of smaller containers, or fold up for storage of larger items on the drawer bottom.

To fold up the shelf, lift to the right until it rests in place against the right side.

The shelf is dishwasher safe, top rack only.

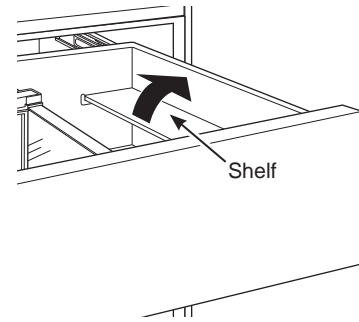

Food storage pan

The bottom drawer offers a pan for storage of smaller items. The pan slides easily to allow storage of and access to larger items in the drawer below.

The pan can be removed, allowing you to carry food to the countertop for preparation or to allow storage space for large food items.

The food storage pan is dishwasher safe, top rack only.

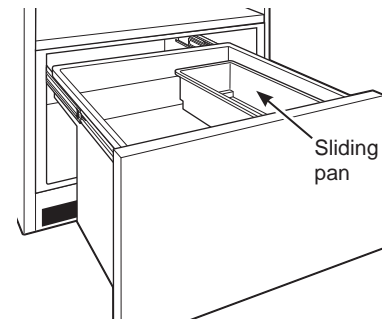

Drawer lights

The brilliant full-width LED lighting in either drawer illuminates when the drawer is opened.

Sabbath Mode

The Sabbath Mode was designed for use on the Jewish Sabbath and Holidays. The Sabbath Mode feature makes it possible for observant Jews to use the beverage center during the duration of the holiday.

The Sabbath Mode feature can be set to override typical reactions caused by your interaction with the beverage center. While in the Sabbath Mode, your appliance will still operate. However, it will not respond to your actions.

While in the Sabbath Mode, you may notice the fan running when the door is opened, however, this is not a result of your actions. The compressor and fan will operate at predetermined times.

ON/OFF - To activate the Sabbath Mode, press and hold down the **+** and **ON/OFF** buttons on the control panel for at least 7 seconds. **SAb** will be displayed on the control. **SAb** will remain in the display and all the control settings will be frozen and stay in the last mode before entering Sabbath Mode.



Controls and lights will not work until the **+** and **ON/OFF** buttons are held again for 7 seconds. The display will show "out" for 1 second and then resume the last operating mode.

For your safety

⚠ WARNING  **Electrical Shock Hazard.**

Turn the double-drawer refrigerator OFF or unplug the unit before cleaning.
Turn the outdoor/indoor refrigerator OFF by pressing the button on the control panel a minimum of 3 seconds until the light and temperature display turn off.

⚠ AVERTISSEMENT  **Risque de choc électrique.**

Éteignez (Off) le réfrigérateur à double tiroir ou débranchez-le avant le nettoyage.
Éteignez (Off) le réfrigérateur à double tiroir en appuyant sur le bouton du panneau de commande durant un minimum de 3 secondes jusqu'à ce que la lampe et l'affichage de température s'éteignent.

Drawer gasket

The vinyl gasket may be cleaned with mild soap and water, or a baking soda solution. Rinse well.

In the event of a power failure

If the power fails, open the drawer as infrequently as possible to maintain the temperature.

Preparing for vacation

For long vacations or absences, remove food and turn the double-drawer refrigerator OFF. Clean the interior (see Cleaning the Inside section)

For shorter vacations, remove perishable foods and leave controls at regular settings. However, if the room temperature is expected to drop below 55°F (13°C), follow the same instructions as for long vacations.

Preparing to move

Secure all loose items such as the shelf, divider and snugger by taping them securely in place to prevent damage.

IMPORTANT: Be sure the double-drawer refrigerator stays in an upright position during moving.

Cleaning the outside

Drawer handles and trim—Clean with a cloth dampened with soapy water. Dry with a soft cloth.

Keep the outside clean. Wipe with a clean cloth lightly dampened with mild liquid dish detergent. Dry with a clean, soft cloth.

Do not wipe the refrigerator with a soiled dish cloth or wet towel. These may leave a residue that can damage the finish. Do not use scouring pads, powdered cleaners, bleach or cleaners containing bleach because these products can scratch and damage the finish.

Stainless steel—The stainless steel doors and door handles (on some models) can be cleaned with a commercially available stainless steel cleaner. Cleaners with oxalic acid such as Bar Keepers Friend Soft Cleanser™ will remove surface rust, tarnish, and small blemishes. Use only a liquid cleaner free of grit and rub in the direction of the brush lines with a damp soft sponge. Do not use appliance wax or polish on the stainless steel.

Cleaning the inside

Unplug the double-drawer refrigerator before cleaning. If this is not practical, turn the unit OFF and wring excess moisture out of the cloth or sponge when cleaning around switches, lights or controls.

Use warm water and baking soda solution—about a tablespoon (15 ml) of baking soda to a quart (1 liter) of water. This both cleans and neutralizes odors. Thoroughly rinse and wipe dry.

Other parts of the double-drawer refrigerator—including the drawer gaskets, divider, snugger, shelf and sliding pan—can be cleaned the same way.

The glass divider, snugger, lever, shelf and food storage pan are dishwasher safe, top rack only.

⚠ CAUTION Do not clean glass shelves or covers with warm water when they are cold. Glass shelves and covers may break if exposed to sudden temperature changes or impact, such as bumping or dropping. Tempered glass is designed to shatter into many small pieces if it breaks.

⚠ ATTENTION Ne nettoyez pas les clayettes ou les couvercles en verre avec de l'eau tiède quand ceux-ci sont froids. Les clayettes et couvercles en verre peuvent se casser s'ils sont exposés à des changements soudains de température ou si vous les cognez ou les faites tomber. Le verre trempé est conçu pour se briser en petits morceaux en cas de casse

Normal operating sounds

Newer appliances sound different from older appliances. Modern appliances have more features and use newer technology.

Do you hear what I hear? These sounds are normal.

HUMMM... WHOOSH...

- The new high efficiency compressor may run faster and longer than your old appliance and you may hear a high-pitched hum or pulsating sound while it is operating.
- Sometimes the appliance runs for an extended period, especially when the drawers are opened frequently.
- You may hear a whooshing sound when the drawers close. This is due to pressure equalizing within the appliance.
- The cabinet fan runs continuously except when the drawer is opened.



- You may hear the fans spinning at high speeds. This happens when the appliance is first plugged in, when the drawer is opened frequently or when a large amount of food is added to the appliance. The fans help maintain desired temperatures.
- If the drawer is open for over 3 minutes, you may hear the fans come on in order to cool the light bulbs.
- The fans change speeds in order to provide optimal cooling and energy savings.

CLICKS, POPS, CRACKS and CHIRPS

- You may hear cracking or popping sounds when the appliance is first plugged in. This happens as the appliance cools to the correct temperature.
- Electronic dampers click open and closed to provide optimal cooling and energy savings.
- The electronic control board may cause a clicking sound when relays activate to control appliance components.
- Expansion and contraction of cooling coils during and after defrost can cause a cracking or popping sound.

WATER SOUNDS



- The flow of refrigerant through the freezer cooling coils may make a gurgling noise like boiling water.
- Water dropping on the defrost heater can cause a sizzling, popping or buzzing sound during the defrost cycle.
- A water dripping noise may occur during the defrost cycle as ice melts from the evaporator and flows into the drain pan.
- Closing the drawer may cause a gurgling sound due to pressure equalization.

The Problem Solver

Double-Drawer Refrigerator

Questions?
Use this
problem
solver!

PROBLEM	POSSIBLE CAUSE
APPLIANCE DOES NOT OPERATE	<ul style="list-style-type: none"> • Appliance is so quiet that most of the time you will hear low or no operating noise. • Appliance may be in defrost cycle when compressor motor does not operate for about 30 minutes. • Controls are set to OFF. Press ON/OFF button on control panel. • If interior light is not on, appliance may not be plugged in at electrical outlet. Push the plug completely into the electrical outlet. • The fuse is blown/circuit breaker is tripped. Replace fuse or reset the breaker. • The appliance is in showroom mode. Unplug it and plug it back in.
VIBRATION OR RATTLING (Slight vibration is normal.)	<ul style="list-style-type: none"> • Adjust the leveling legs as shown in the Installation Instructions.
COMPRESSOR MOTOR OPERATES FOR LONG PERIODS OR CYCLES ON AND OFF FREQUENTLY	<ul style="list-style-type: none"> • Normal when appliance is first plugged in. Wait 24 hours for the appliance to completely cool down. • Often occurs when large amounts of beverages are placed in appliance. This is normal. • Drawer left open or package holding drawer open. • Hot weather or frequent drawer openings. This is normal. • Temperature control set at the coldest setting. See Temperature Control.
FRESH FOOD OR FREEZER COMPARTMENT TOO WARM	<ul style="list-style-type: none"> • Temperature control not set cold enough. See Temperature Control. • Warm weather or frequent drawer openings. • Drawer left open for long time. • Package may be holding drawer open.
FROST OR ICE CRYSTALS ON REAR WALL	<ul style="list-style-type: none"> • Too frequent or too long drawer openings.
APPLIANCE HAS ODOR	<ul style="list-style-type: none"> • Interior needs cleaning. See Care and Cleaning. • Keep open box of baking soda in appliance; replace every 3 months.
DRAWER NOT CLOSING PROPERLY	<ul style="list-style-type: none"> • Drawer gasket is sticking or folding over. Apply petroleum jelly or paraffin wax to the face of the gasket. • The drawer is hitting an internal component inside the appliance. Adjust interior components to prevent interference.
MOISTURE FORMS ON OUTSIDE OF APPLIANCE	<ul style="list-style-type: none"> • Not unusual during periods of high humidity. Wipe surface dry. • Drawer left open or package holding drawer open.
MOISTURE COLLECTS INSIDE	<ul style="list-style-type: none"> • Too frequent or too long drawer openings. • In humid weather, air carries moisture into appliance when drawers are opened.

The Problem Solver

Double-Drawer Refrigerator

Questions?
Use this
problem
solver!

PROBLEM	POSSIBLE CAUSE
INTERIOR LIGHT DOES NOT WORK	<ul style="list-style-type: none">• No power at outlet.• Light bulb needs replacing. See Care and Cleaning.• Controls are set to OFF. Press ON/OFF pad on control panel.• The Sabbath Mode may be operating. Turn off Sabbath Mode.
HOT AIR FROM BOTTOM OF APPLIANCE	<ul style="list-style-type: none">• Normal air flow cools the motor. In the refrigeration process, it is normal that heat be expelled in the area under the appliance. Some floor coverings are sensitive and will even discolor at these safe and normal temperatures.
APPLIANCE NEVER SHUTS OFF BUT TEMPERATURES ARE OK	<ul style="list-style-type: none">• Adaptive defrost keeps compressor running during drawer openings. This is normal. The appliance will cycle off after the drawer remains closed for two hours.• Normal operation in extreme temperatures.
ACTUAL TEMPERATURE NOT EQUAL TO SET TEMPERATURE	<ul style="list-style-type: none">• Unit just plugged in. Allow 24 hours for the system to stabilize.• Drawer open for too long. Allow 24 hours for the system to stabilize.• Warm contents added to appliance. Allow 24 hours for the system• Defrost cycle is in process. Allow 24 hours for the system to stabilize.
TEMPERATURE WILL NOT ADJUST	<ul style="list-style-type: none">• Temperature may be in lockout mode. Press both + and – pads for 5 seconds to unlock the temperature.

YOUR MONOGRAM DOUBLE-DRAWER REFRIGERATOR WARRANTY Staple sales slip or canceled check here. Proof of original purchase date is needed to obtain service under warranty.

WHAT IS COVERED

From the Date of the Original Purchase

LIMITED TWO-YEAR WARRANTY

For two years from date of original purchase, we will provide, free of charge, parts and service labor in your home to repair or replace *any part of the unit* that fails because of a manufacturing defect.

LIMITED THIRD THROUGH FIFTH-YEAR WARRANTY

For the third through fifth years from date of original purchase, we will provide, free of charge, parts and service labor in your home to repair or replace *any part of the sealed refrigerating system* (the compressor, condenser, evaporator and all connecting tubing) that fails because of a manufacturing defect.

This warranty is extended to the original purchaser and any succeeding owner for products purchased for ordinary home use in the 48 mainland states, Hawaii, Washington, D.C. or Canada. If the product is located in an area where service by a Monogram Authorized Servicer is not available, you may be responsible for a trip charge or you may be required to bring the product to an Authorized Monogram Service location for service. In Alaska the warranty is the same except that it is LIMITED because you must pay to ship the product to the service shop or for the service technician's travel costs to your home.

All warranty service will be provided by our Factory Service Centers or by our authorized Customer Care® servicers during normal working hours.

Should your appliance need service, during warranty period or beyond, in the USA call 800-444-1845. In Canada: 888.880.3030. Please have your serial number and model number available when calling for service.

WHAT IS NOT COVERED

- Service trips to your home to teach you how to use the product.
- Replacement of house fuses or resetting of circuit breakers.
- Damage to the product caused by accident, fire, floods or acts of God.
- Failure of the product if it is used for other than its intended purpose or used commercially.
- Damage caused after delivery.
- Improper installation, delivery or maintenance.
- Replacement of the light bulbs, if included.
- Loss of food due to spoilage (in the USA only).
- Incidental or consequential damage caused by possible defects with this appliance.
- Product not accessible to provide required service.
- Damage to finish, such as surface rust, tarnish, or small blemishes not reported within 48 hours of delivery.

If you have an installation problem, contact your dealer or installer. You are responsible for providing adequate electrical, plumbing and other connecting facilities.

EXCLUSION OF IMPLIED WARRANTIES—Your sole and exclusive remedy is product repair as provided in this Limited Warranty. Any implied warranties, including the implied warranties of merchantability or fitness for a particular purpose, are limited to one year or the shortest period allowed by law.

Some states/provinces do not allow the exclusion or limitation of incidental or consequential damages, so the above limitation or exclusion may not apply to you. This warranty gives you specific legal rights, and you may also have other rights which vary from state to state/province to province. To know what your legal rights are in your state/province, consult your local or state/provincial consumer affairs office or your state's Attorney General.

Warrantor: GE Appliances, a Haier company

Warrantor in Canada: MC Commercial, Burlington, ON, L7R 5B6

With the purchase of your new Monogram appliance, receive the assurance that if you ever need information or assistance from Monogram, we will be there. All you have to do is call!

Register Your Appliance

Register your new appliance on-line at your convenience! Timely product registration will allow for enhanced communication and prompt service under the terms of your warranty, should the need arise. You may also mail in the pre-printed registration card included in the packing material.

In the US: **Monogram.com**

In Canada: **Prodsupport.mabe.ca/crm/Products/ProductRegistration.aspx**

Schedule Service

Expert Monogram repair service is only one step away from your door. Get on-line and schedule your service at your convenience any day of the year.

In the US: **Monogram.com** or call 800.444.1845 during normal business hours.

In Canada: **Monogram.ca** or call 888.880.3030

Extended Warranties

Purchase a Monogram extended warranty and learn about special discounts that are available while your warranty is still in effect.

In the US: **Monogram.com** or call 800.444.1845 during normal business hours.

In Canada: **Monogram.ca** or call 888.880.3030.

Remote Connectivity

For assistance with wireless network connectivity (for models with remote enable), visit our website at **Monogram.com** or call 800.444.1845 in the US only.

Parts and Accessories

Individuals qualified to service their own appliances can have parts or accessories sent directly to their homes (VISA, MasterCard and Discover cards are accepted). Order on-line today 24 hours every day.

In the US: **Monogram.com** or by phone at 800.444.1845 during normal business hours.

Instructions contained in this manual cover procedures to be performed by any user. Other servicing generally should be referred to qualified service personnel. Caution must be exercised, since improper servicing may cause unsafe operation.

Customers in Canada should consult the nearest Mabe service center, visit our website at **Monogram.ca** or call 888.880.3030.
