

SAMSUNG

Quick Setup Guide



1-800-SAMSUNG (7267864)

Samsung Electronics America, Inc.
105 Challenger Road Ridgefield Park, NJ 07660-0511

Samsung Electronics Canada Inc., Customer Service
55 Standish Court Mississauga, Ontario L5R 4B2

Call center hours of operation (Mon-Sun 9AM-12AM EST).

To register this product please visit
www.samsung.com/global/register.

LN32A550P3F/LN37A550P3F/
LN40A550P3F/LN46A550P3F/
LN52A550P3F

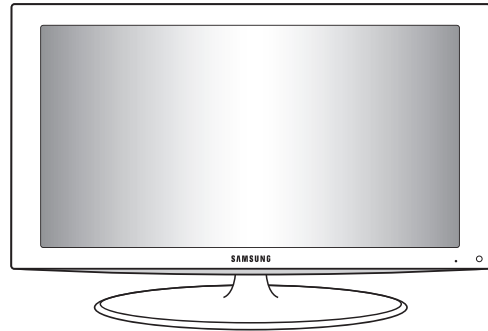

Rear Panel / Side Panel Jacks

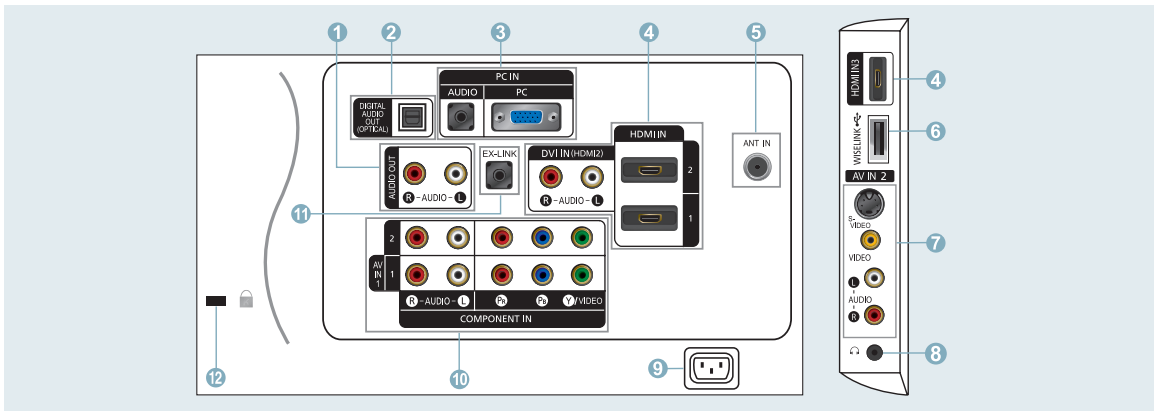

- | | | |
|--|--------------------|--------------------------------|
| 1 AUDIO OUT | 5 ANT IN | 9 POWER INPUT |
| 2 DIGITAL AUDIO OUT (OPTICAL) | 6 WISELINK | 10 COMPONENT IN 1, 2 / AV IN 1 |
| 3 PC IN [PC] / [AUDIO] | 7 AV IN 2, S-VIDEO | 11 EX-LINK |
| 4 HDMI IN 1, 2, 3 / DVI IN (HDMI2) [R-AUDIO-L] | 8 HEADPHONE | 12 KENSINGTON LOCK |

Video Input Performance Comparison







	HDMI/DVI	Best
	PC/COMPONENT	Better
	S-VIDEO	Good
	VIDEO	Normal

Audio Output Performance Comparison

	OPTICAL (Digital)	Best
	AUDIO (Analog)	Normal

Remote Control

See "Remote Control" in the owner's instructions for details.

- 1 POWER**
Turns the TV on and off.
- 2 TV**
Selects the TV mode directly.
- 3 NUMERIC BUTTONS**
Press to change the channel.
- 4** 
Press to select additional channels (digital and analog) being broadcast by the same station. For example, to select channel "54-3", press "54", then press "" and "3".
- 5**  **(MUTE)**
Press to temporarily cut off the sound.
- 6 VOL - / VOL +**
Press to increase or decrease the volume.
- 7 CH LIST**
Used to display Channel Lists on the screen.
- 8 TOOLS**
Use to quickly select frequently used functions.
- 9 INFO**
Press to display information on the TV screen.
- 10 COLOR BUTTONS**
Use these buttons in the Channel list, WISELINK, etc.
- 11 CC**
Controls the caption decoder.
- 12 E.MODE**
Press to select the preset display and sound modes for sports, cinema and games.
- 13** Use these buttons in the DMA, WISELINK and Anynet+ modes.
: This remote can be used to control recording on Samsung recorders with the Anynet+ feature)
- 14**  **ON/OFF**
Press to backlight the buttons on the remote. This function is convenient for using at night or when the room is dark. (Using the remote control with the **ON/OFF**  light button set to On will reduce the battery usage time.)

- 15 PRE-CH**
Tunes to the previous channel.
- 16 CH ∨ / CH ∧**
Press to change channels.
- 17 SOURCE**
Press to display and select the available video sources.
- 18 W.LINK (WISELINK)**
This function enables you to view and play photo and music files from an external device.
- 19 MENU**
Displays the main on-screen menu.
- 20 RETURN**
Returns to the previous menu.
- 21 UP ▲ / DOWN ▼ / LEFT ◀ / RIGHT ▶ / ENTER** 
Use to select on-screen menu items and change menu values.
- 22 EXIT**
Press to exit the menu.
- 23 DMA (Digital Media Adapter)**
Use this when connecting a SAMSUNG DMA device through an HDMI interface and switching to DMA mode.

For more information on the operating procedures, refer to the user manual of the DMA.

This button is available when "Anynet+(HDMI-CEC)" is "On".
- 24 MTS**
Press to choose stereo, mono or Separate Audio Program (SAP broadcast).
- 25 FAV.CH**
Press to switch to your favorite channels.
- 26 P.SIZE**
Picture size selection.

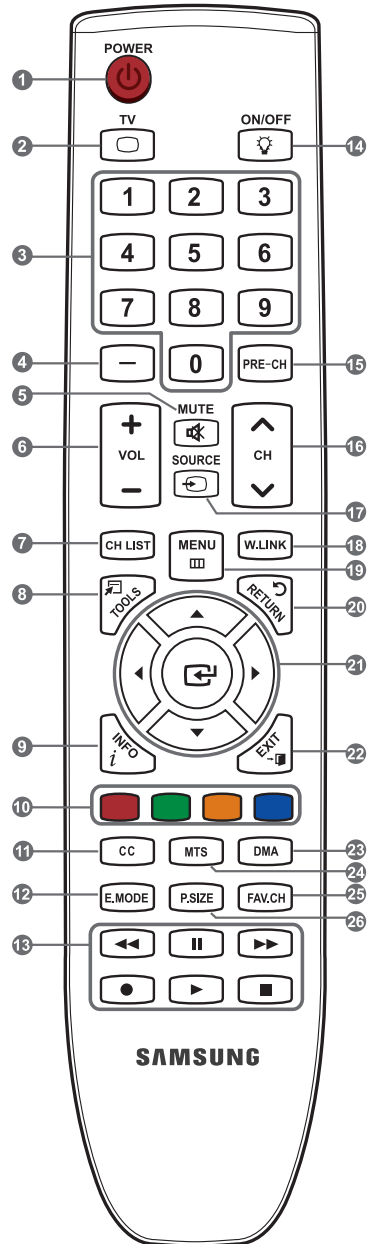

Connecting a DVD Player or Cable Box/Satellite receiver (Set-Top Box) via HDMI

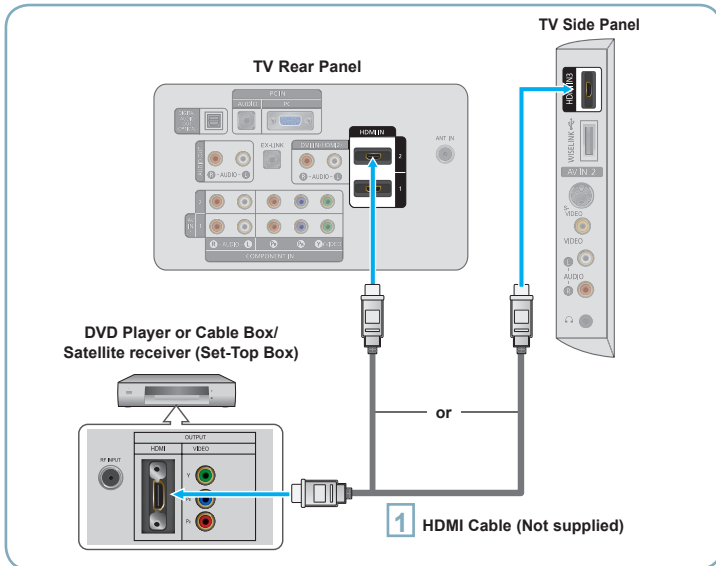

- 1 Connect an HDMI Cable between the HDMI IN (1, 2 or 3) jack on the TV and the HDMI jack on the DVD Player or Cable Box/Satellite receiver (Set-Top Box).

What is HDMI?

- HDMI (High-Definition Multimedia Interface), is an interface that enables the transmission of digital audio and video signals using a single cable.
- The difference between HDMI and DVI is that the HDMI device is smaller in size and has the HDCP (High Bandwidth Digital Copy Protection) coding feature installed.

- Each DVD Player or Cable Box/Satellite receiver (Set-Top Box) has a different back panel configuration.
- The TV may not output sound and pictures may be displayed with abnormal color when DVD players/Cable Boxes/Satellite receivers supporting HDMI versions older than 1.3 are connected. When connecting an older HDMI cable and there is no sound, connect the HDMI cable to the HDMI IN 2 jack and the audio cables to the DVI IN (HDMI2) [R-AUDIO-L] jacks on the back of the TV. If this happens, contact the company that provided the DVD player/Cable Box/Satellite receiver to confirm the HDMI version, then request an upgrade.
- HDMI cables that are not 1.3 may cause annoying flicker or no screen display.

Connecting a DVD Player or Cable Box/Satellite receiver (Set-Top Box) via DVI

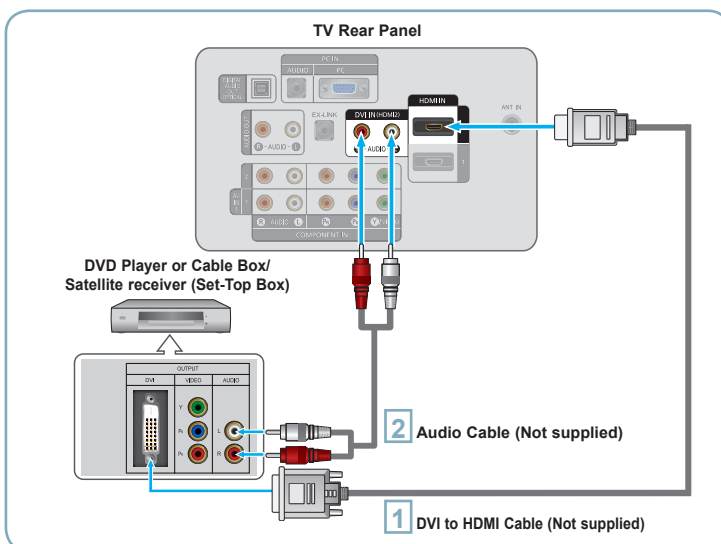

- 1 Connect a DVI to HDMI Cable or DVI-HDMI Adapter between the HDMI IN 2 jack on the TV and the DVI jack on the DVD Player or Cable Box/Satellite receiver (Set-Top Box).

- 2 Connect Audio Cables between the DVI IN (HDMI 2) [R-AUDIO-L] jack on the TV and the DVD Player or Cable Box/Satellite receiver (Set-Top Box).

- Each DVD Player or Cable Box/Satellite receiver (Set-Top Box) has a different back panel configuration.
- When connecting a DVD Player or Cable Box/Satellite receiver (Set-Top Box), match the color of the connection terminal to the cable.
- When using an HDMI/DVI cable connection, you must use the HDMI IN 2 jack.

Connecting a DVD Player or Cable Box/Satellite receiver (Set-Top Box) via Component cables

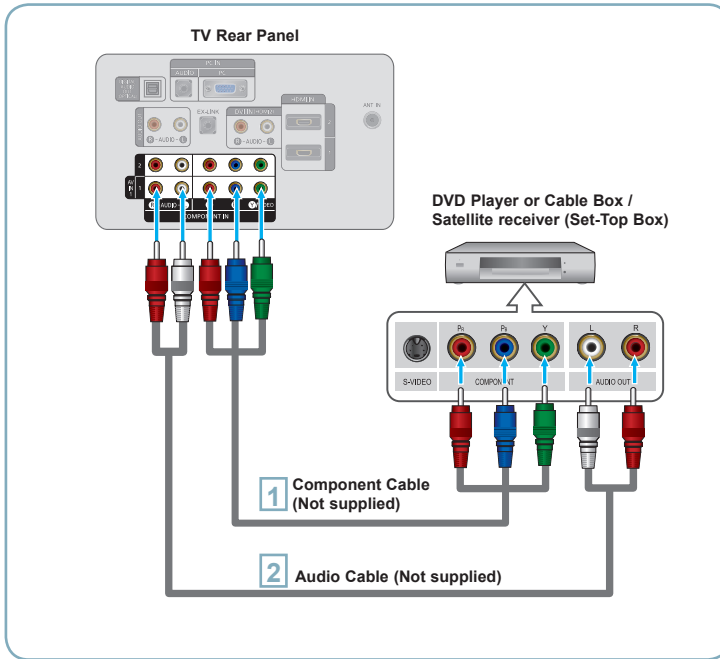

1 Connect a Component Cable between the COMPONENT IN (1 or 2) [Y, Pb, Pr] jacks on the TV and the COMPONENT [Y, Pb, Pr] jacks on the DVD Player or Cable Box/Satellite receiver (Set-Top Box).

2 Connect Audio Cables between the COMPONENT IN(1 or 2) [R-AUDIO-L] jacks on the TV and the AUDIO OUT jacks on the DVD Player or Cable Box/Satellite receiver (Set-Top Box).

- Component video separates the video into Y (Luminance (brightness)), Pb (Blue) and Pr (Red) for enhanced video quality. Be sure to match the component video and audio connections. For example, if connecting a Component video cable to COMPONENT IN 1, connect the audio cable to COMPONENT IN 1 also.
- Each DVD Player or Cable Box/Satellite receiver (Set-Top Box) has a different back panel configuration.
- When connecting a DVD Player or Cable Box/Satellite receiver (Set-Top Box), match the color of the connection terminal to the cable.

Connecting a Camcorder

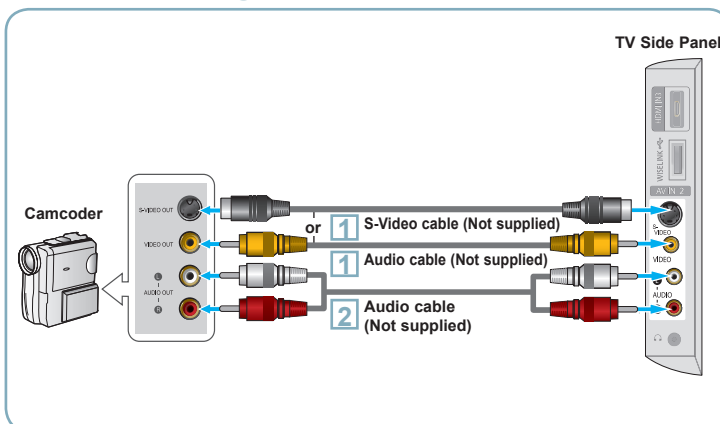

1 Connect a Video Cable (or S-Video Cable) between the AV IN2 [VIDEO] (or S-VIDEO) jack on the TV and the VIDEO OUT jack on the camcorder.

2 Connect Audio Cables between the AV IN2 [R-AUDIO-L] jacks on the TV and the AUDIO OUT jacks on the camcorder.

- Each Camcorder has a different back panel configuration.
- When connecting a Camcorder, match the color of the connection terminal to the cable.

Connecting a VCR

Video Connection

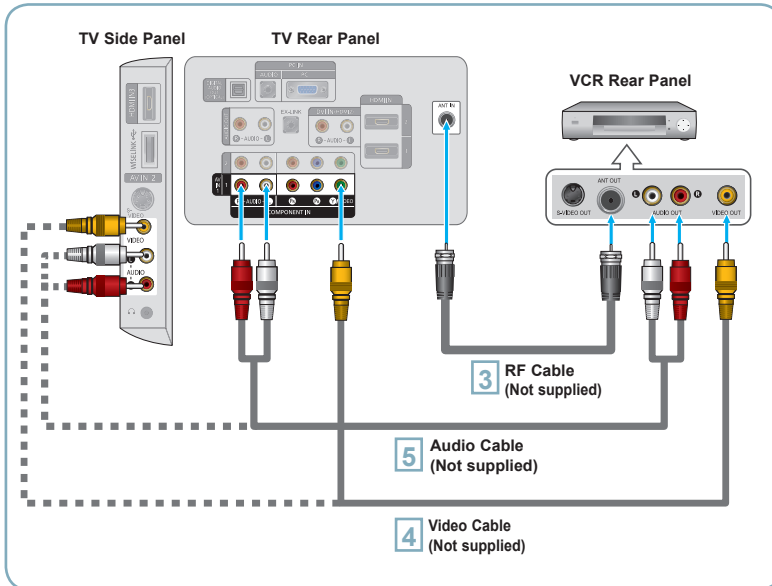

- 1 Unplug the cable or antenna from the back of the TV.
 - 2 Connect the cable or antenna to the ANT IN terminal on the back of the VCR.
 - 3 Connect an RF Cable between the ANT OUT terminal on the VCR and the ANT IN terminal on the TV.
 - 4 Connect a Video Cable between the VIDEO OUT jack on the VCR and the AV IN 1 [Y/VIDEO] or AV IN 2 [VIDEO] jack on the TV.
 - 5 Connect Audio Cables between the AUDIO OUT jacks on the VCR and the AV IN 1 (or AV IN 2) [R-AUDIO-L] jacks on the TV.
- > If you have a "mono" (non-stereo) VCR, use a Y-connector (not supplied) to hook up to the right and left audio input jacks of the TV. If your VCR is stereo, you must connect two cables.

Follow the instructions in "Viewing a VCR or Camcorder Tape" to view your VCR tape.

- > Each VCR has a different back panel configuration.
- > When connecting a VCR, match the color of the connection terminal to the cable.
- > When connecting to AV IN 1, the color of the AV IN 1 [Y/VIDEO] jack (Green) does not match the color of the video cable (Yellow).

S-Video Connection

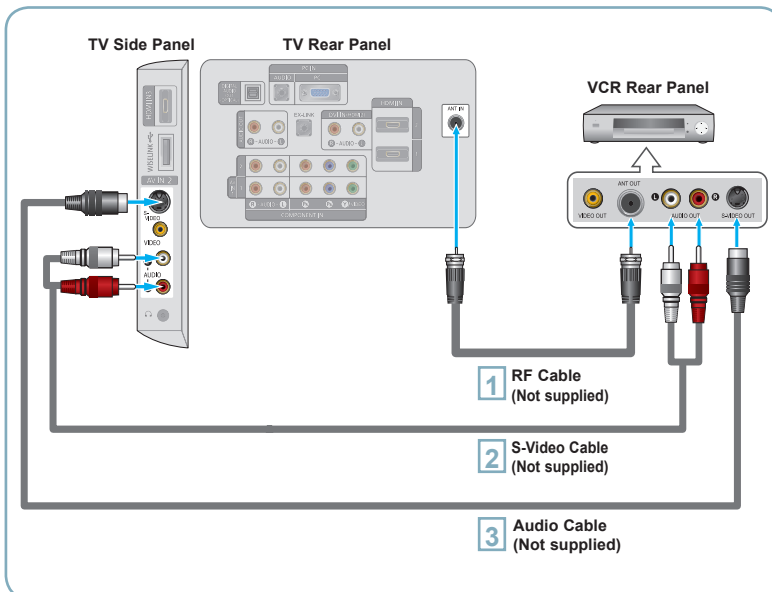

- 1 To begin, follow steps 1–3 in the previous section to connect the antenna or cable to your VCR and your TV.
- 2 Connect an S-Video Cable between the S-VIDEO OUT jack on the VCR and the AV IN 2 [S-VIDEO] jack on the TV.
- 3 Connect Audio Cables between the AUDIO OUT jacks on the VCR and the AV IN 2 [R-AUDIO-L] jacks on the TV.

An S-Video cable may be included with a VCR. (If not, check your local electronics store.)

- > Each VCR has a different back panel configuration.
- > When connecting a VCR, match the color of the connection terminal to the cable.

Connecting a Digital Audio System

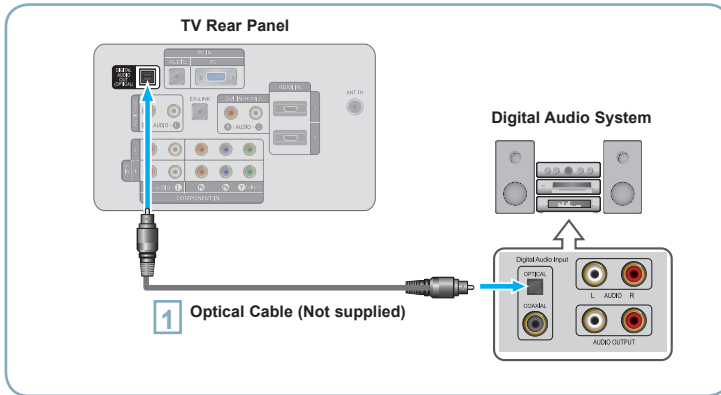

- 1 Connect an Optical Cable between the "DIGITAL AUDIO OUT (OPTICAL)" jacks on the TV and the Digital Audio Input jacks on the Digital Audio System.

When a Digital Audio System is connected to the "DIGITAL AUDIO OUT (OPTICAL)" jack: Decrease the volume of the TV and adjust the volume level with the system's volume control.

- 5.1CH audio is possible when the TV is connected to an external device supporting 5.1CH.
- Each Digital Audio System has a different back panel configuration.
- When the receiver (home theater) is set to On, you can hear sound output from the TV's Optical jack. When the TV is displaying a DTV(air) signal, the TV will send out 5.1 channel sound to the Home theater receiver. When the source is a digital component such as a DVD and is connected to the TV via HDMI, only 2 channel sound will be heard from the Home Theater receiver. If you want to hear 5.1 channel audio, connect the DIGITAL AUDIO OUT (OPTICAL) jack on the DVD player or Cable/Satellite Box directly to an Amplifier or Home Theater, not the TV.

Connecting an Amplifier/DVD Home Theater

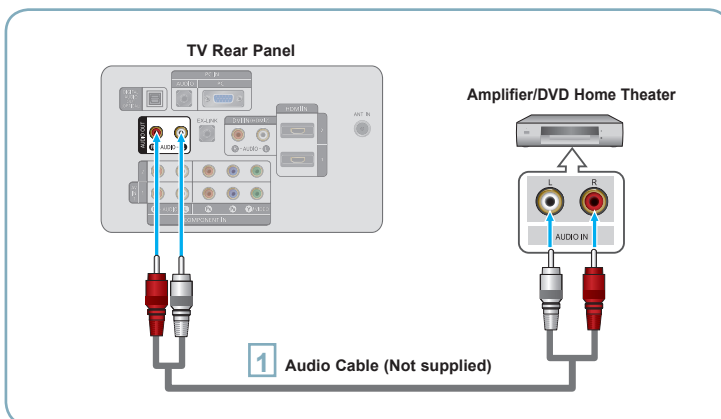

- 1 Connect Audio Cables between the AUDIO OUT [R-AUDIO-L] jacks on the TV and AUDIO IN [R-AUDIO-L] jacks on the Amplifier/DVD Home Theater.

When an audio amplifier is connected to the "AUDIO OUT [R-AUDIO-L]" jack: Decrease the volume of the TV and adjust the volume level with the Amplifier's volume control.

- Each Amplifier/DVD Home Theater has a different back panel configuration.
- When connecting an Amplifier/DVD Home Theater, match the color of the connection terminal to the cable.

Connecting a PC

Using the D-Sub Cable

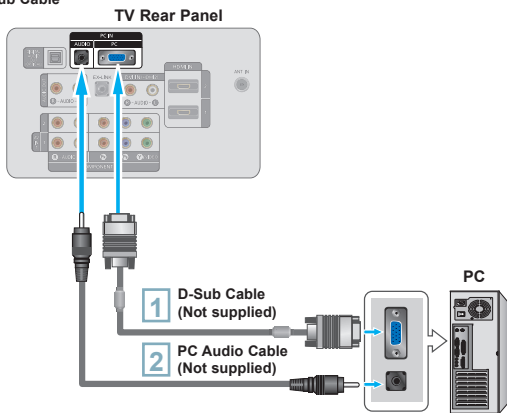

Using the HDMI/DVI Cable

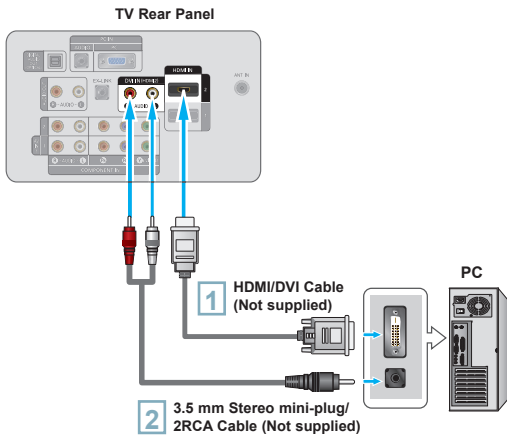

Using the D-Sub Cable

- 1 Connect a D-Sub Cable between PC IN [PC] connector on the TV and the PC output connector on your computer.
- 2 Connect a PC Audio Cable between the PC IN [AUDIO] jack on the TV and the Audio Out jack of the sound card on your computer.

Using the HDMI/DVI Cable

- 1 Connect an HDMI/DVI cable between the HDMI IN 2 jack on the TV and the PC output jack on your computer.
- 2 Connect a 3.5 mm Stereo mini-plug/2RCA Cable between the DVI IN (HDMI2) [R-AUDIO-L] jack on the TV and the Audio Out jack of the sound card on your computer.

- Each PC has a different back panel configuration.
- When connecting a PC, match the color of the connection terminal to the cable.
- When using an HDMI/DVI cable connection, you must use the HDMI IN 2 terminal.

Turning the TV On and Off

Press the **POWER** button on the remote control. You can also use the **POWER** button on the TV.

Viewing the Menus

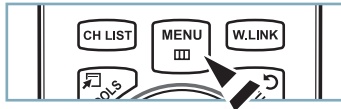

- 1 With the power on, press the **MENU** button. The main menu appears on the screen. The menu's left side has icons: Picture, Sound, Channel, Setup, Input, Application.
- 2 Press the **▲** or **▼** button to select one of the icons. Then press the **ENTER** button to access the icon's sub-menu. Press the **EXIT** button to exit.
 - > The on-screen menus disappear from the screen after about one minute.

Storing Channels in Memory (Automatic Method)

- 1 Press the **MENU** button to display the menu. Press the **▲** or **▼** button to select "Channel", then press the **ENTER** button.
- 2 Press the **▲** or **▼** button to select "Auto Program", then press the **ENTER** button.
- 3 Press the **▲** or **▼** button to select the antenna connection, then press the **ENTER** button.

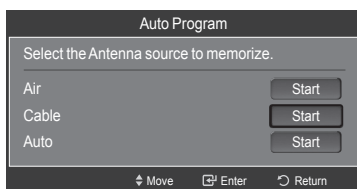

- 4 When selecting the Cable TV system: Press the **ENTER** button to start the auto program. Press the **▲**, **▼**, **◀** or **▶** to select the correct analog signal cable system source among "STD", "HRC", and "IRC". Press the **▲** or **▼** button to select "Start", then press the **ENTER** button. If you have Digital cable TV, select the cable system signal source for both Analog and Digital.

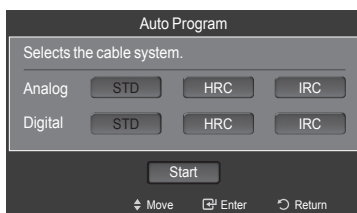

- 5 The TV begins memorizing all available stations. Press the **EXIT** button to exit.

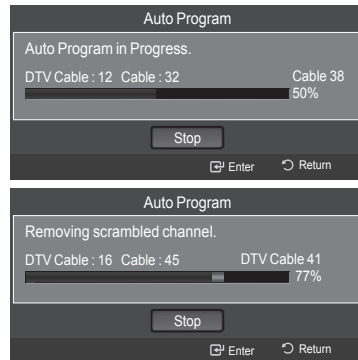

- > After all the available channels are stored, it starts to remove scrambled channels. The Auto program menu then reappears.

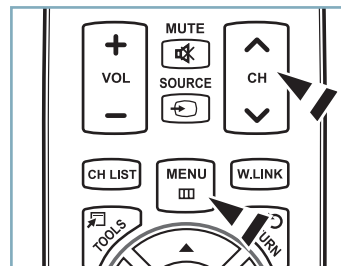

To Stop the Auto Program Function

Press the **MENU** button while the Auto Program function is being executed. You can also press the **ENTER** button to stop the setup.

Checking to see if Channels were Stored in Memory

Press the **CH** button. Only the channels stored in memory will be selected (in order).

Selecting the antennas

- **Air:** "Air" antenna signal.
- **Cable:** "Cable" antenna signal.
- **Auto:** "Air" and "Cable" antenna signals.

Setting the Channel List

You can delete or add a channel to display the channels you want.

- 1 Press the **MENU** button. Press the **▲** or **▼** button to select "Channel", then press the **ENTER** button. Press the **▲** or **▼** button to select "Channel List", then press the **ENTER** button.
- 2 Press the **◀** button to select "Added Channels". Press the **▲** or **▼** button to select "All Channels". Press the **ENTER** button.
- 3 Press the **▲** or **▼** button to select a channel to delete, then press the **TOOLS** button. Press the **ENTER** button to select "Delete".
- 4 Press the **▲** or **▼** button to select a channel to add, then press the **TOOLS** button. Press the **ENTER** button to select "Add".



Changing the Picture Standard

You can select the type of picture which best corresponds to your viewing requirements.

- 1 Press the **MENU** button to display the menu. Press the **ENTER** button, to select "Picture".
- 2 Press the **ENTER** button to select "Mode". Press the **▲** or **▼** button to select "Dynamic", "Standard" or "Movie". Press the **ENTER** button.

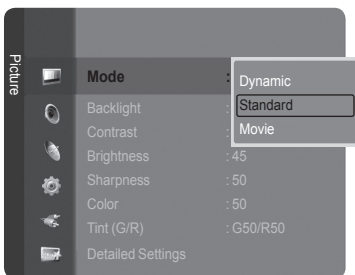

Picture Mode

- **Dynamic:** Selects the picture for high-definition in a bright room.
- **Standard:** Selects the picture for the optimum display in a normal environment.
- **Movie:** Selects the picture for viewing movies in a dark room.

Customizing the Picture Settings

Your television has several setting options that allow you to control the picture quality.

- 1 To select the desired picture mode, follow the "Changing the Picture Standard" instructions numbers 1 and 2.
- 2 Press the **▲** or **▼** button to select "Backlight", "Contrast", "Brightness", "Sharpness", "Color" or "Tint(G/R)", then press the **ENTER** button.
- 3 Press the **◀** or **▶** button to decrease or increase the value of a particular item. Press the **EXIT** button to exit.
 - > When you make changes to "Backlight", "Contrast", "Brightness", "Sharpness", "Color" or "Tint(G/R)", the OSD will be adjusted accordingly.
 - > In PC mode, you can only make changes to "Backlight", "Contrast" and "Brightness".
 - > Settings can be adjusted and stored for each external device you have connected to an input of the TV.

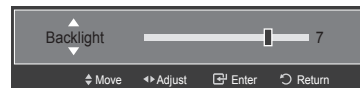
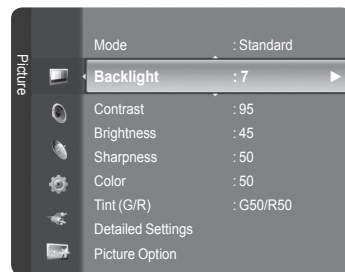

Picture Adjustment

- **Backlight:** Adjusts the brightness of LCD back light.
- **Contrast:** Adjusts the contrast level of the picture.
- **Brightness:** Adjusts the brightness level of the picture.
- **Sharpness:** Adjusts the edge definition of the picture.
- **Color:** Adjusts color saturation of the picture.
- **Tint(G/R):** Adjusts the color tint of the picture.

To Select the Source

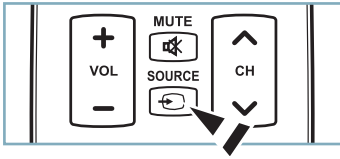

Press the SOURCE button on the Remote Control

You can select the TV mode or an input source connected to the TV set. Use this button to choose an input source that you would like to watch.

- Available signal sources: TV, AV1, AV2, S-Video, Component1, Component2, PC, HDMI1, HDMI2/DVI, HDMI3, USB.
- You can choose only those external devices that are connected to the TV. In the "Source List", connected inputs will be highlighted and sorted to the top. Inputs that are not connected will be sorted to the bottom.
- Using the Color buttons on the remote with the Source list
 - Red (Refresh): Refreshes the connecting external devices.
 - TOOLS (Option): Displays the "Edit Name" and "Information" menus.

Troubleshooting

If the TV seems to have a problem, first try this list of possible problems and solutions.
If none of these troubleshooting tips apply, call your nearest Samsung service center.

Problem	Possible Solution
Poor picture	Try another channel. / Adjust the antenna. / Check all wire connections.
Poor sound quality.	Try another channel. / Adjust the antenna.
No picture or sound.	Try another channel. / Press the SOURCE button. / Make sure the TV is plugged in. / Check the antenna connections.
No sound or sound is too low at maximum volume.	First, check the volume of units connected to your TV (digital broadcasting receiver, DVD, cable broadcasting receiver, VCR, etc.). Then, adjust the TV volume accordingly.
Picture rolls vertically.	Check all wire connections.
The TV operates erratically.	Unplug the TV for 30 seconds, then try operating it again.
The TV won't turn on.	Make sure the wall outlet is working.
Remote control malfunctions	Replace the remote control batteries. Clean the upper edge of the remote control (transmission window). Check the battery terminals.
"Check signal cable" message.	Ensure that the signal cable is firmly connected to the PC source.
"Not Supported Mode" message.	Check the maximum resolution and connected device's Video frequency. Compare these values with the data in the Display Modes.
Digital broadcasting screen problem.	Please check the digital signal strength and input antenna.
The image is too light or too dark.	Adjust the Brightness and Contrast. / Adjust the Fine tuning.
Black bars on the screen.	Make sure the broadcast you're receiving is High Definition (HD). HD channels sometimes broadcast Standard Definition (SD) programming, which can cause black bars. Set your cable/satellite box to stretch or widescreen mode to eliminate the bars.
Picture has a Red/Green or Pink tint.	Make sure the Component cables are connected to the correct jacks.
Closed Captioning not working.	If you are using a Cable/Satellite box, you must set Closed Captioning on the box, not your TV.
Snowy picture.	Your cable box may need a firmware upgrade. Please contact your Cable company.
Ghosting on picture	This is sometimes caused by compatibility issues with your cable box. Try connecting Component cables instead.
Horizontal bars appear to flicker, jitter or shimmer on the image.	Adjust the Coarse tuning and then adjust the Fine tuning.
Vertical bars appear to flicker, jitter or shimmer on the image.	Adjust the Coarse tuning and then adjust the Fine tuning.
Screen is black and power indicator light blinks steadily.	On your computer check: Power, Signal Cable. The TV is using its power management system. Move the computer's mouse or press any key on the keyboard.
Image is not centered on the screen.	Adjust the horizontal and vertical position. The screen position must be adjusted on the output source (i.e. STB) with a digital signal.
The picture appears distorted in the corner of the screen.	If "Just Scan" is selected with some external devices, the picture may appear distorted in the corner of the screen. This symptom is caused by the external devices, not TV.
The "Resets all settings to the default values" message appears.	This appears when you press and hold the EXIT button for a while. The product settings are reset to the factory defaults.



Contact SAMSUNG WORLDWIDE

If you have any questions or comments relating to Samsung products, please contact the SAMSUNG customer care center.

Contacte con SAMSUNG WORLDWIDE

Si tiene alguna pregunta o comentario referente a nuestros productos, por favor contacte con nuestro Servicio de Atención al Cliente.

Country	Customer Care Center ☎	Web Site	Address
CANADA	1-800-SAMSUNG(726-7864)	www.samsung.com/ca	Samsung Electronics Canada Inc., Customer Service 55 Standish Court Mississauga, Ontario L5R 4B2 Canada
			Samsung Electronique Canada Inc., Service à la Clientèle 55 Standish Court Mississauga, Ontario L5R 4B2 Canada
U.S.A	1-800-SAMSUNG(726-7864)	www.samsung.com	Samsung Electronics America, Inc. 105 Challenger Road Ridgefield Park, NJ 07660-0511



BN68-01393A-00