

Amana[®] Chest Freezer

PRODUCT MODEL NUMBERS

AQC0501
AQC0701
AQC0902

Electrical: A 115 Volt, 60 Hz., AC only 15 or 20 amp fused (or circuit breaker), grounded electrical supply is required. It is recommended that a separate circuit serving only your freezer be provided. Use an outlet that cannot be turned off by a switch or pull chain. Do not use an extension cord.

PRODUCT DIMENSIONS

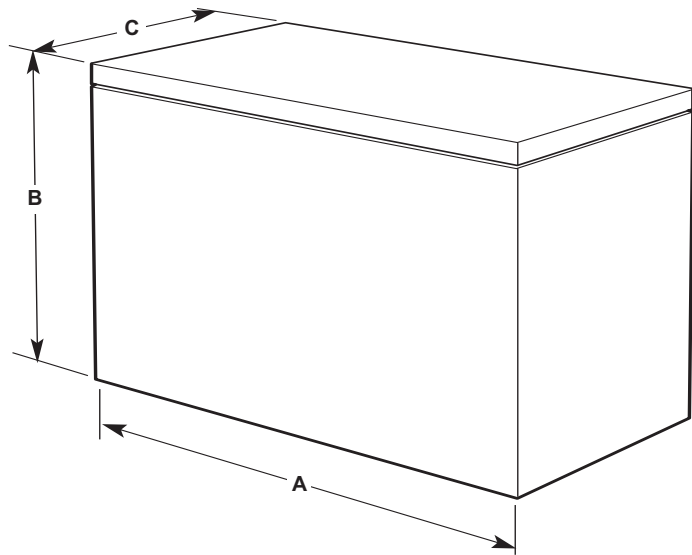

| Model Numbers | Model Size | Width "A" | Height "B" | Depth "C" |
|---------------|-------------|--|-------------------|--|
| AQC0501 | 5.3 cu. ft. | 30" (76.2 cm) | 32½" (82.6 cm) | 22" (55.9 cm) |
| AQC0701 | 7 cu. ft. | 38 ⁹ / ₁₆ " (98.0 cm) | 32½" (82.6 cm) | 22 ¹ / ₁₆ " (56 cm) |
| AQC0902 | 9 cu. ft. | 44" (111.8 cm) | 33¼" (84.5 cm) | 24" (61 cm) |

LOCATION REQUIREMENTS

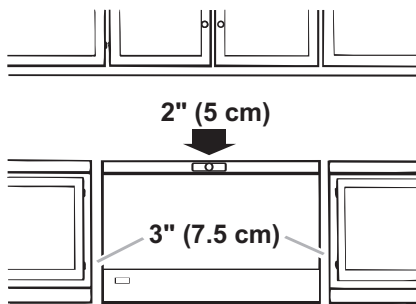

Allow at least 3 in. (7.5 cm) of air space on both sides of the freezer and 2 in. (5 cm) between the back of the freezer and the wall. Leave room above the freezer to open the lid.

Your freezer operates most efficiently when located in an area where the temperature is normally between 32°F (0°C) and 110°F (43°C).

Do not install the freezer near an oven, radiator or other heat source.

Check the strength of the floor before installing your freezer. It should hold the weight of a freezer fully loaded with food.