

AMERICAN RANGE

PROFESSIONAL QUALITY COOKING EQUIPMENT

PERFORMER SERIES
60" Range with Open Gas Burners



ARROB-660GDGR

(shown with optional 4" stub back and leg caps)

Shown in stainless steel, to customize the color, go to www.americanrange.com



DESIGN



CLASS



FUNCTION

DESIGNED & BUILT IN USA
PROFESSIONAL COOKING EQUIPMENT

60" RESIDENTIAL GAS RANGE

RANGE TOP FEATURES

- True commercial lift-off burners for easy cleaning
- 3 sizes of burners to serve your everyday needs: 25,000 BTU (lg), 18,000 BTU (md) and 12,000 BTU (sm)
- Variable infinite flame settings for all open top burners
- Automatic, electronic ignition with fail-safe system ensures, re-ignition in the event the flame goes, out even on the lowest burner setting
- Continuous commercial-grade cast iron grates
- Porcelainized burner pans catch spills and lift out for easy cleaning
- Analog controls provide easy, push to turn operation ensuring child safety
- Blue LED light indicates oven functions
- Heavy-duty metal die-cast black satin knobs with chrome bezels
- Stainless Steel Island Back Trim included and installed
- Front panel switch controls oven lighting for optimal visibility
- One-piece durable precision frame construction oven front

OVEN FEATURES

- Multiple functions include: Standard Bake, Convection Bake, Infrared Broil and Fan modes
- Convection system optimizes uniform airflow
- Two chrome plated heavy-duty racks with 4 positions on heavy chrome side supports
- Accommodates full size commercial sheet pan
- Ceramic Infrared Broiler provides rapid searing at 1,800° F
- Quick preheat times & uniform cooking temp. with 28,000 BTU Bake Burner
- Extra-large viewing window in oven door
- Porcelainized oven interior simplifies cleaning

CONVECTION OVEN TECHNOLOGY

Balanced turbulent heat distribution is essential when baking, roasting food.

The American Range convection oven technology features a convection motor of louvered side panels to enhance uniform heat distribution throughout the large oven cavity.

The strategic placement of the convection fan ensures consistent heat distribution even when challenged with cooking the largest turkey, ham or roast.



CONVECTION OVEN IS GREEN TECHNOLOGY

The highly efficient design of the Convection Oven uses less gas versus a standard oven.

TECHNICAL SPECIFICATIONS

Overall Oven Capacity	4.4 CU. FT. each oven
Oven Dimensions	26-1/2" W x 19" D x 15" H each oven
Surface Burner Rating	25,000 BTU (lg) - 18,000 BTU (md) - 12,000 BTU (sm)
Griddle Burner Rating	20,000 BTU for every 11" section
Grill Burner Rating	18,000 BTU for every 11" section
Infrared Broiler	17,000 BTU each oven
Oven Bake Burner	28,000 BTU each oven
Total Gas Connection Rating per model #	ARROB-6602GD 219,000 BTU 6 burners & double griddle ARROB-660GDGR 217,000 BTU 6 burners, griddle & grill ARROB-660X2GR 215,000 BTU 6 burners & double grill ARROB-1060 259,000 BTU 10 burners
Gas Supply	7" W.C. Natural, 11" W.C. Propane
Electrical Supply	120VAC 15 AMP 60 Hz Single Phase
Shipping Weight	780 Lbs

ACCESSORIES AND OPTIONS

Island back (standard) ARR-60SIB-P	12" Cutting Board ARR-CUTB12-P	24" Grill Cover ARR-GRCOV24-P	22" Chrome Griddle w/ Separator MCSP-P
Island back (welded) ARR-60IB-P	12" Griddle Cover ARR-GDSCOV12-S-P	11" Chrome Flat Griddle Plate MC11-FS-P	Porcelainized Broiler Pan R31005
4" Stub Back ARR-604SB-P	12" Grill Cover ARR-GRCOV12-S-P	11" Chrome Grooved Griddle Plate MC11-GG-P	Wok Adapter ARR-WOK-P
20" High back w/ Shelf ARR-6021HBS-P	12" Griddle Plate ARR-PGP12-P	22" Chrome Flat Griddle Plate MC22-FS-P	Extra Oven Rack 30" Oven R31013
S/S Curb base ARR-60CB-P	24" Griddle Plate ARR-PGP24-P	22" Chrome L- Flat R - Grooved Griddle MC-HG-P	
Stainless Steel Leg Caps (3) ARR-3LC-P	24" Griddle Cover ARR-GDCOV24-S-P	22" Chrome Grooved Griddle MCGG-P	

N = Natural gas Must ship from factory with proper gas type. **L** = LP Gas Must provide **N** or **L** after model number for type of gas needed. **Example: ARROB-6602GD-L** Must specify elevation if over 1000 ft. when ordering.

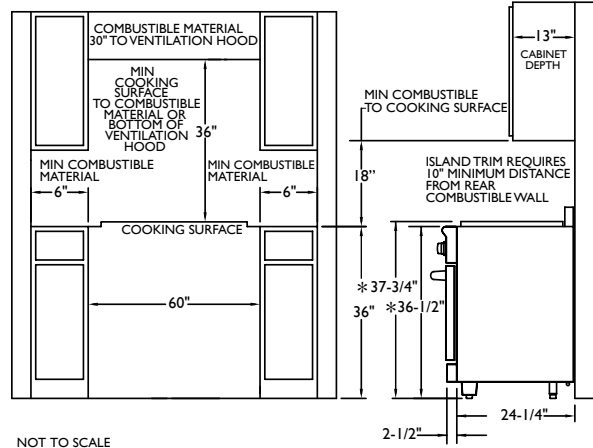

*ADJUSTABLE + 1-1/4"
ISLAND OR PENINSULA INSTALLATIONS 10" MINIMUM CLEARANCE FROM BACK OF RANGE TO COMBUSTIBLE SURFACE ISLAND TRIM IS 0". CLEARANCE TO NON COMBUSTIBLE SURFACE NO SIDEWALL ABOVE COOKING SURFACE

A MANUAL GAS SHUT-OFF VALVE MUST BE INSTALLED EXTERNAL TO THE APPLIANCE, IN A LOCATION ACCESSIBLE FROM THE FRONT. FOR THE PURPOSE OF SHUTTING OFF THE GAS SUPPLY. THE SUPPLY LINE MUST NOT INTERFERE WITH THE BACK OF THE UNIT.

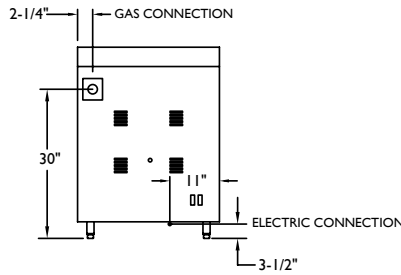

BURNER CONFIGURATIONS

● 25,000 BTU (lg) ● 18,000 BTU (md) ● 12,000 BTU (sm)

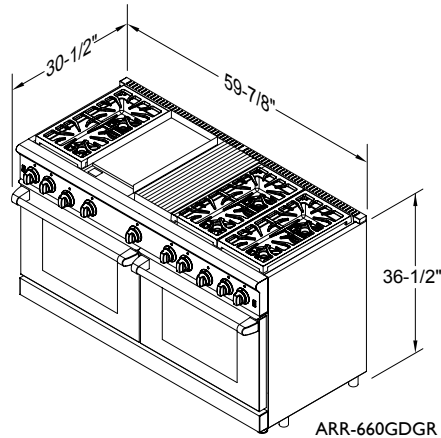
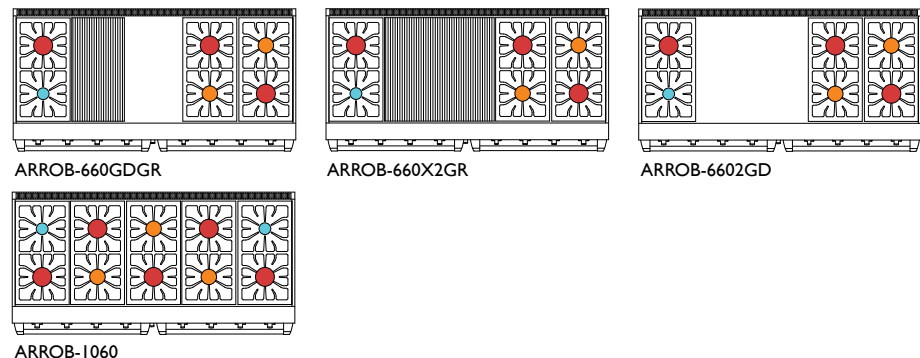

NOT TO SCALE

R70408 02262015

DESIGNED & BUILT IN USA

13592 Desmond St., Pacoima, CA 91331 818.897.0808 888.753.9898 tel www.americanrange.com

