



ARBM150SE

15 cu ft. Refrigerator , Stainless steel, bottom mount



Selected Model	
Model number	ARBM150SE
Exterior Appearance	
Door Design	Slightly Curved
Handle Type	Recessed handle
Freestanding	Yes
Counter-Depth	Yes
Cabinet color	Grey
Frontage Color	Stainless steel
Concealed Hinges	No
Reversible Door	Yes
Dimensions	
Overall Height (in.)	67,7 cu ft
Overall Width (in.)	27,6"
Depth with door	26,5"
Depth with door open to 90 degree	52,8"
Depth without door (out of all)	24,1"
Width with door open to 130 degree	45,5 "
Features	
Configuration	Single door
Freezer Type	Freezer drawer
Temperature Management Control	Electronic soft touch control
Door swing	Right
Interior Lighting	LED lights
Control Panel	Inside
Ref Storage bin	4 smalls (2 with covers) + 2 large door bins
Depth (po)	26,5 cu ft
Freezer storage	2 large drawers + 1 ice tray & ice bin
Shelves	3 spill proof Glass shelves
Capacity	
Total Capacity	14.8 cu ft
Refrigerator Capacity	10,58 cu ft
Freezer Capacity	4.22 cu ft
Gas type	
R600A	R600A
Electrical Requirements	
Energy Consumption	ENERGY STAR
Volts; Hertz; Amps	120V; 60Hz; 15 Amp
Warranty	
3 Year warranty Sealed system (parts)	3 Year warranty Sealed system (parts)
Complete 2 year warranty parts & labor	Complete 2 year warranty parts & labor

ARBM150SE

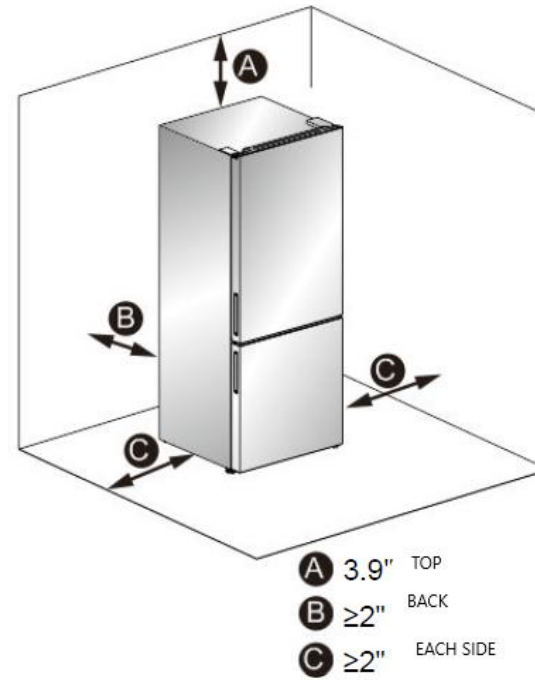
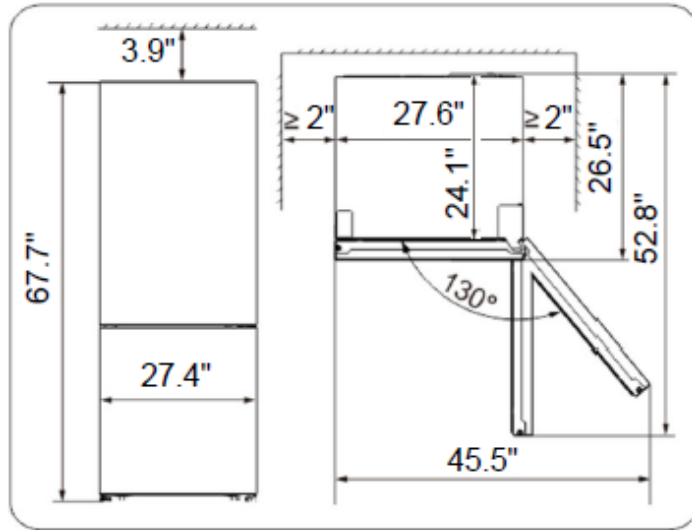

- A** 3.9" TOP
- B** ≥2" BACK
- C** ≥2" EACH SIDE

Dimensions de l'unité unit dimension		Dimensions boîte Box dimension
Width (In.)	27.4"	29.5"
Depth (in.) cabinet	26.5	28.9"
Height (in.)	67.7"	71.9"
weight NET/GROSS	Net: 70 kg/154 lbs	Gross: 77.56 kg/ 171 lbs
Width (without door)	25 1/2"	
Depth including door open to 90 degree	52.8"	
Width including door opened to 130 degree	45.5"	