



ARBM172SE

17 cu ft. Refrigerator 2 doors, Stainless steel, bottom mount



| | |
|--|--|
| Selected Model | |
| Model number | ARBM172SE |
| Exterior Appearance | |
| Door Design | Flat door |
| Handle Type | Recessed handle |
| Freestanding | Yes |
| Counter-Depth | Yes |
| Frontage Color | Stainless steel |
| Reversible Door | Yes |
| Dimensions | |
| Overall Height (in.) | 69 1/4" |
| Overall Width (in.) | 31" |
| Features | |
| Configuration | Single door |
| Freezer Type | Bottom door |
| Temperature Management Control | Electronic soft touch control |
| Door swing | Right |
| Interior Lighting | LED lights |
| Control Panel | Inside |
| Ref Storage bin | 4 smalls + 2 large door bins |
| Depth (po) | 28 1/2" |
| Freezer storage | 2 large drawers + 1 ice tray |
| Capacity | |
| Total Capacity | 17.1 cu. ft |
| Refrigerator Capacity | 12.15 cu.ft |
| Freezer Capacity | 4.95 cu ft. |
| Electrical Requirements | |
| Energy Consumption | ENERGY STAR |
| Warranty | |
| 3 Year warranty Sealed system (parts) | 3 Year warranty Sealed system (parts) |
| Complete 2 year warranty parts & labor | Complete 2 year warranty parts & labor |

ARBM172SE/WE/BSE

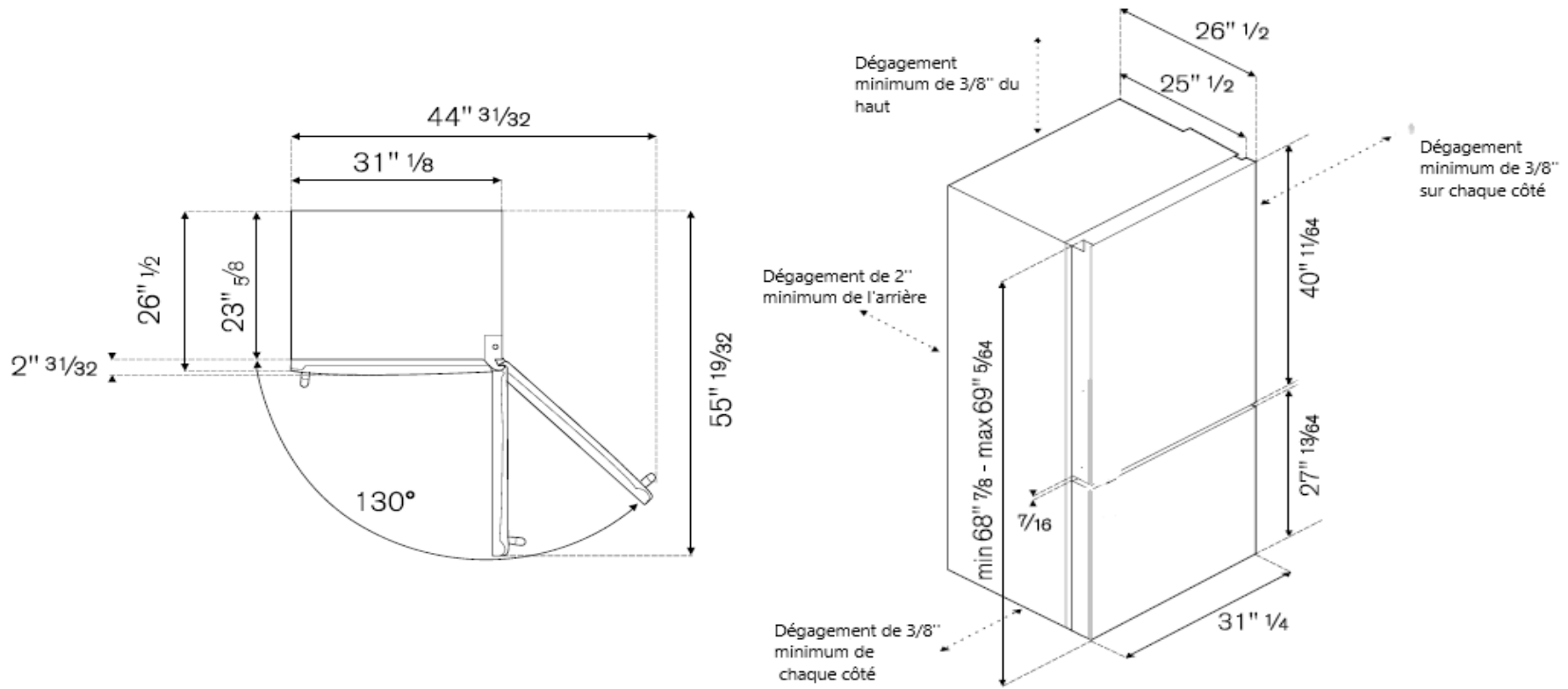

| Unit dimension | | Box dimension |
|---|--------------------------|------------------------------|
| Width (in.) | 31,1 | 33,75 |
| Depth (in.) cabinet | 28,5 | 28,6 |
| Height (in.) | 69,1 | 71,6 |
| Weight NET/GROSS | Net: 87,40 kg/192,28 lbs | Gross: 106,45 kg/ 234,19 lbs |
| Depth without door | 25 1/2" | |
| Height Freezer door | 27 13/64" | |
| Height Refrigerator door | 40 11/64" | |
| Space between Refrigerator & freezer door | 7/16" | |
| Depth including door 90 degree open | 55 19/32" | |
| With including door 130 degree open | 44 31/32" | |