

## PRODUCT DIMENSIONS

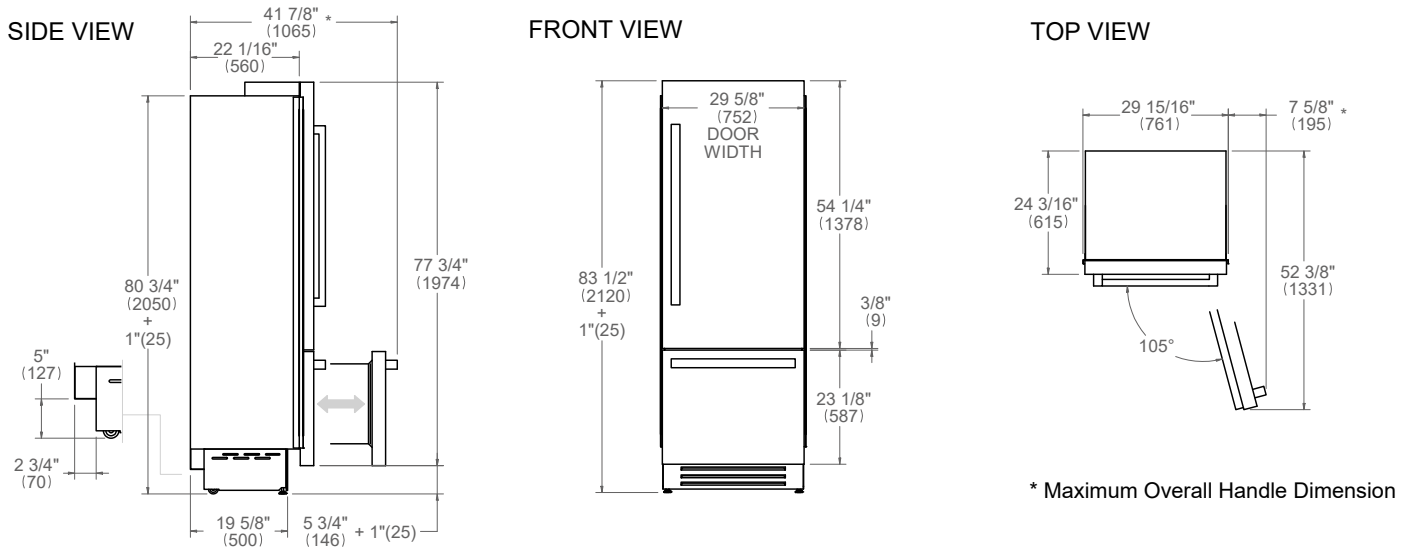

## CUTOUT DIMENSIONS

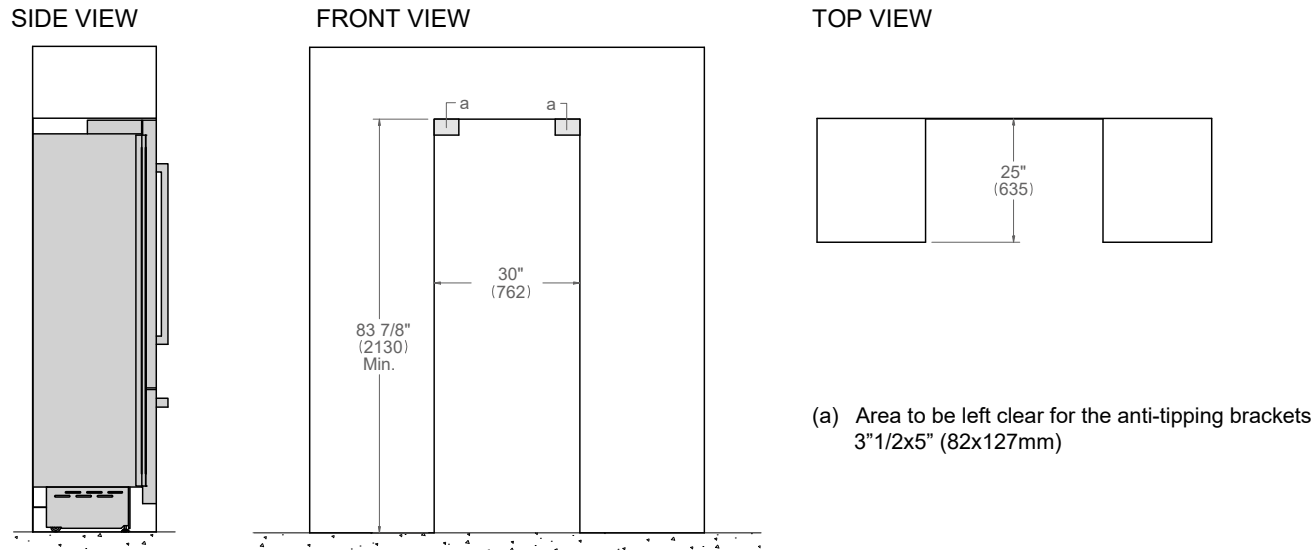

## ELECTRICAL & WATER CONNECTION

**E** A properly-grounded, horizontally-mounted electrical receptacle should be installed according to this drawing

**W** To connect to the water supply system, a  $\frac{1}{4}''$  NPT waterline with accessible shut-off valve must be supplied.

Connection(s) placement within the opening may require additional cabinet depth.

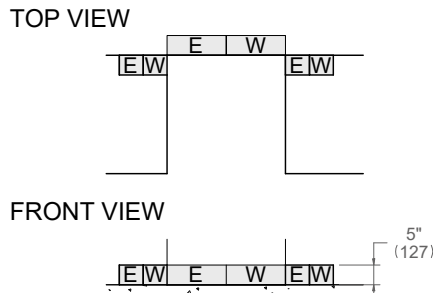

## INSTALLATION REQUIREMENTS

If the appliance(s) is not connected through the side profile trims to secured cabinetry anti-tip brackets must be installed.

A separate circuit breaker servicing only this appliance is recommended. For installation of multiple products in combination, refer to the Built-in Food Preservation Design Guide. Dimensions in parentheses are millimeters unless otherwise specified.