

PRODUCT DIMENSIONS

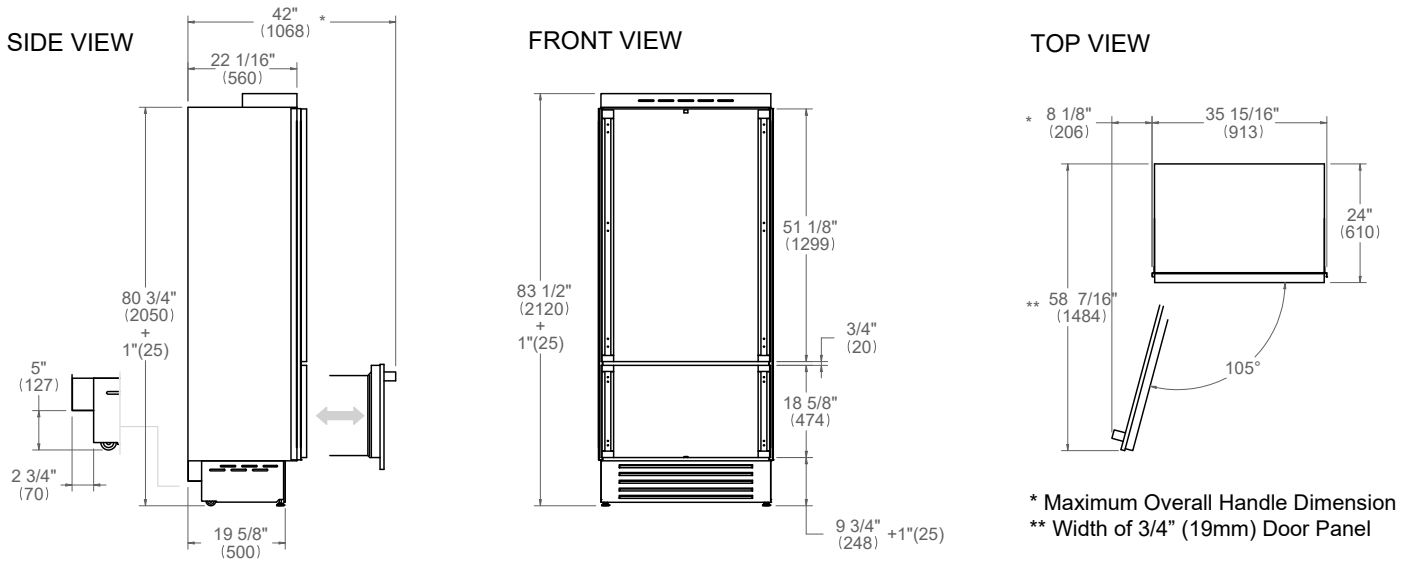

CUTOUT DIMENSIONS

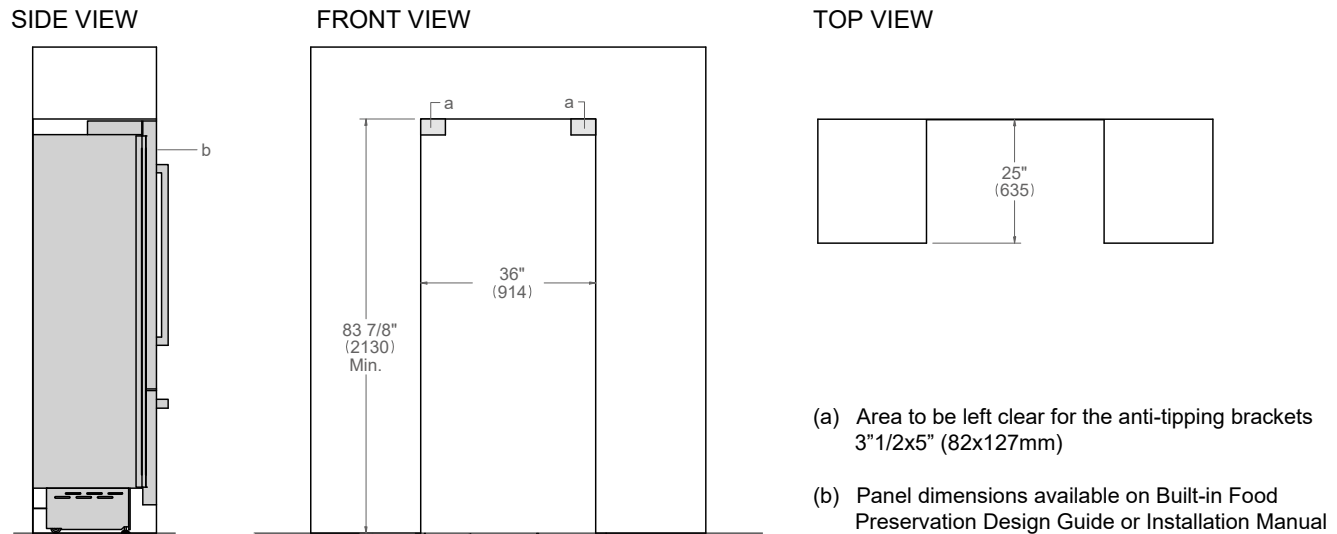

ELECTRICAL & WATER CONNECTION

- E** A properly-grounded, horizontally-mounted electrical receptacle should be installed according to this drawing
- W** To connect to the water supply system, a 1/4" NPT waterline with accessible shut-off valve must be supplied.

Connection(s) placement within the opening may require additional cabinet depth.

A separate circuit breaker servicing only this appliance is recommended. For installation of multiple products in combination, refer to the Built-in Food Preservation Design Guide. Dimensions in parentheses are millimeters unless otherwise specified.

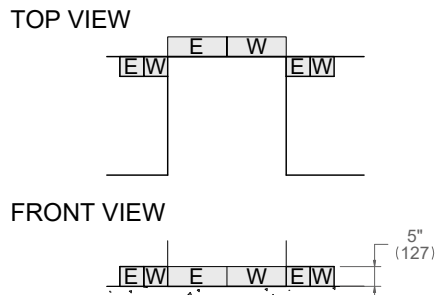

INSTALLATION REQUIREMENTS

If the appliance(s) is not connected through the side profile trims to secured cabinetry anti-tip brackets must be installed.