

---

# BERTAZZONI MASTER SERIES

36" 5 BURNER ELECTRIC OVEN

MAS36 5 DFM XE



The handsome Bertazzoni Master Series ranges bring a true professional touch to your cooking. They are fully engineered for performance and designed with standard dimensions to work with existing kitchen layouts and units. The Master 36" dual fuel range has an oven with several cooking modes and European convection, providing balanced air flow and even heat distribution for single and multi-level roasting and baking with no flavor crossover. The oven includes soft-motion door hinges for easy one-hand operation and triple-glass windows to minimize heat loss. The beautiful worktop is precision-molded off of one sheet of stainless steel. It is configured with five versatile gas burners, including Bertazzoni's signature dual-ring power burner with independently controlled flames for high power to delicate simmer. The worktop is designed for high-efficiency in heat delivery without energy waste. Each burner is equipped with the thermocouple gas shut-off safety system for maximum safety. Complete your Bertazzoni range with any of the available ventilation and blacksplash solutions, as well as low profile trim, toekick and other beautiful accessories.

## ELECTRIC CONVECTION OVEN

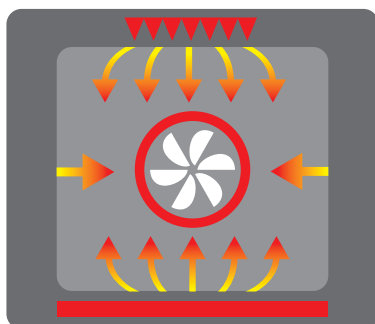

Bertazzoni dual-fuel ranges are equipped with extra-wide European convection ovens with heat-assisted convection fan, providing balanced air flow and even heat distribution.

## CONTROLS



Ranges are controlled by large round soft-touch knobs and feature a professional style handle.



TO COOK BEAUTIFULLY

# BERTAZZONI MASTER SERIES

## 36" 5 BURNER ELECTRIC OVEN - MAS36 5 DFM XE

### FEATURES

Gas burners	5
Burner type	aluminium
Maintop	one piece stainless steel sheet
Burner controls	knobs
Knobs	soft touch
Grates	cast iron
Backguard	standard 4 inches
Gas safety device	thermocouple technology
One hand ignition	standard
Standard accessories	wok ring & simmer plate
Dual Power burner	750 - 18,000 Btu/h
Rapid burner	11,000 Btu/h
Semi-rapid burner	6500 Btu/h
Auxiliary burner	3400 Btu/h
Simmer rate	750 Btu/h
Main oven	electric convection with electric broiler
Main oven functions	bake, traditional bake, upper bake, broil, large broil, convection broil, convection, defrost/ dehydrate
Main oven volume	4.4 ft <sup>3</sup>
Inner oven door	full width triple glass
Oven equipment	1 baking tray, 2 heavy gauge wire shelves, 1 grill trivet for tray
Legs	height adjustable stainless steel legs

### TECHNICAL SPECIFICATIONS

Voltage, frequency	120/240 V, 60Hz
Max Amp Usage, power rating	12 A - 2400 W, 13.5 A - 3100 W
Certification	CSA
Warranty	2 years parts and labor

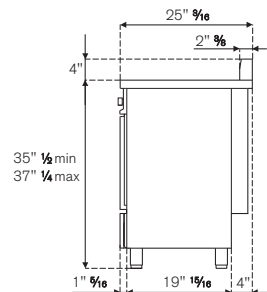
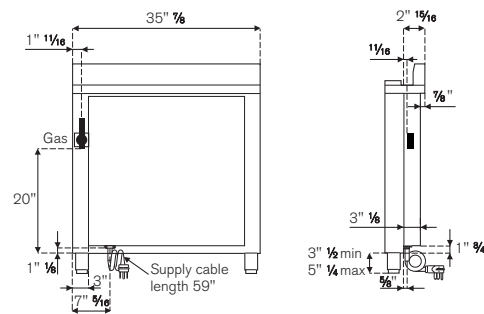
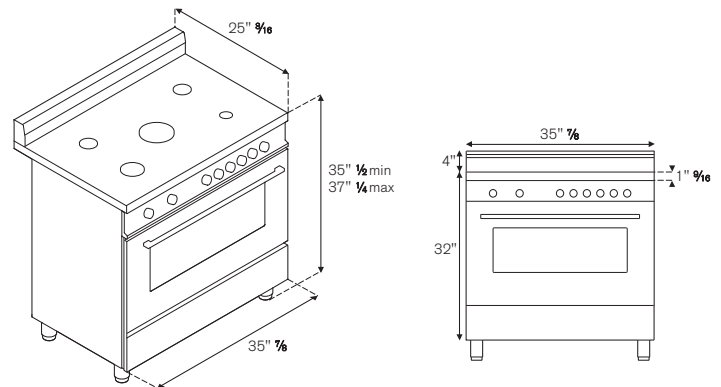

### INSTALLATION INSTRUCTIONS

Bertazzoni recommends to operate the appliance after it has been installed in a cabinet. The kitchen cabinets shall be made of materials capable of withstanding temperatures at least 117°F (65°C) above room temperature in order to avoid possible damage to the cabinets during oven usage. For further installation instructions refer to the installation manual.

### ACCESSORIES

Toe kick panel (TKS 36 X), flat island trim (IRF 36 X), side trim (ST 36 X)

### MATCHING VENTILATION SOLUTIONS

Bertazzoni offers a variety of matching ventilation solutions for this range. Please check our website under the ventilation tab for a complete overview of all choices

**Disclaimer:** while every effort has been made to insure the accuracy of the information contained in this brochure, Fratelli Bertazzoni reserves the right to change any part of the information at any time without notice.

Fratelli Bertazzoni, Bertazzoni and the winged wheel brand icon are registered trademarks of Bertazzoni Spa.