

PRODUCT DIMENSIONS

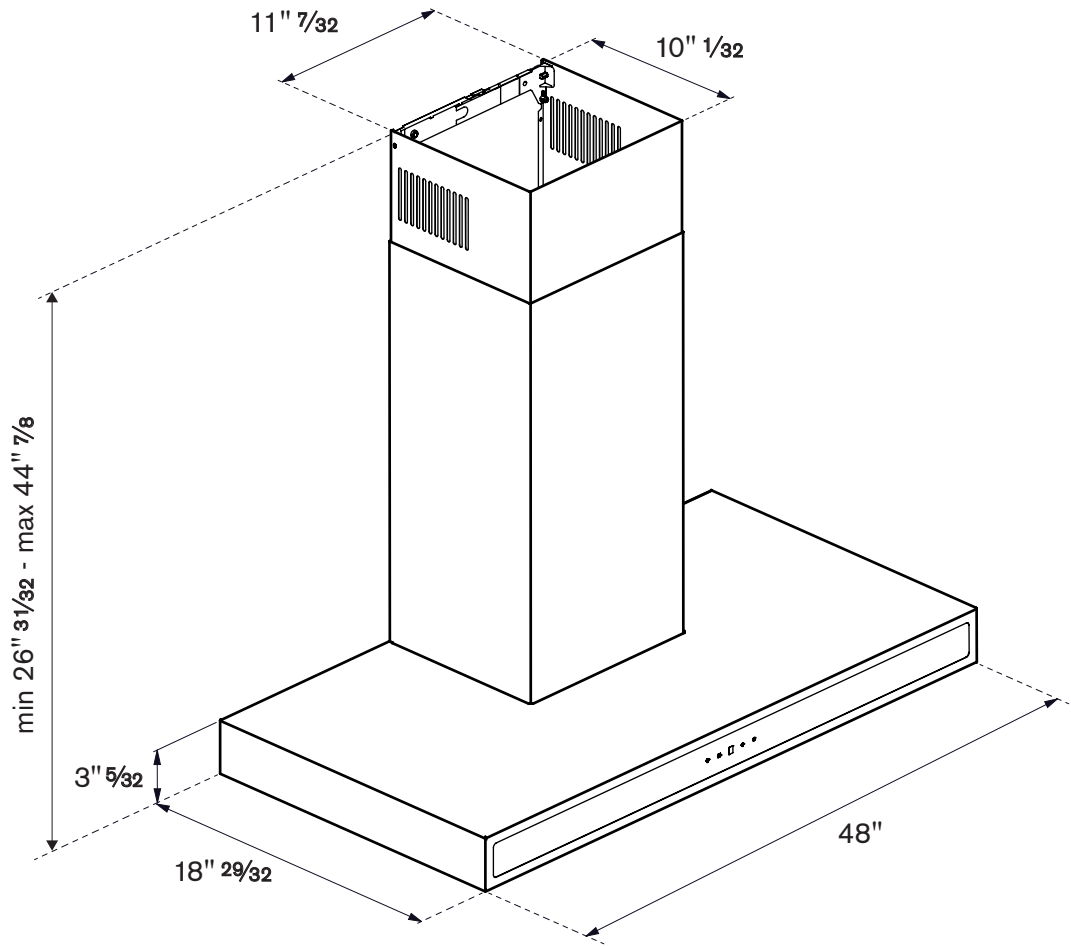

SIDE VIEW

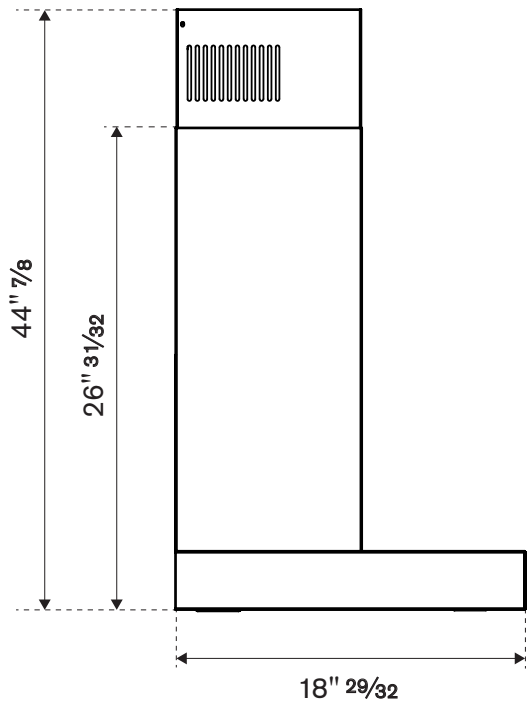

PRODUCT INSTALLATION

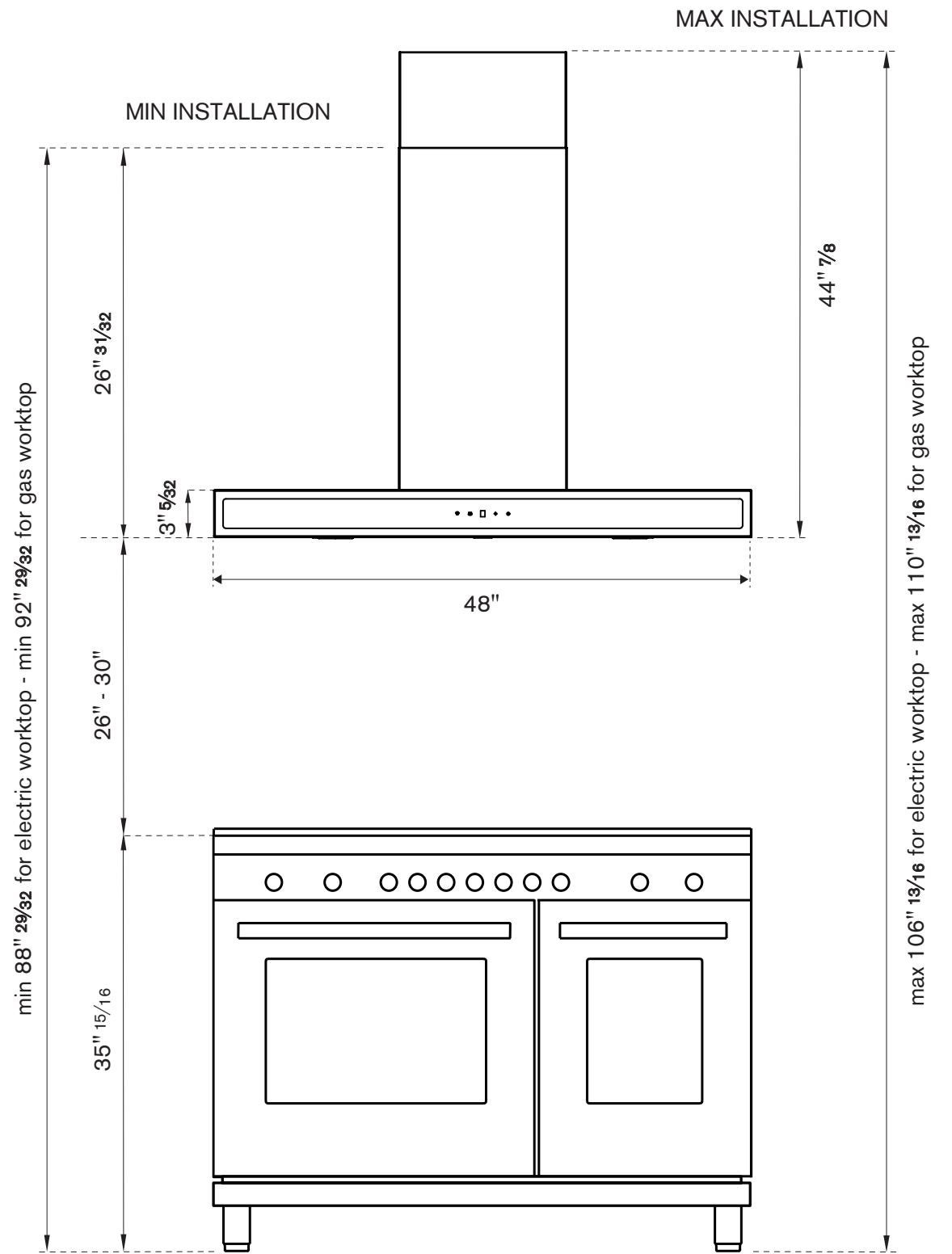

Hood Clearance

Recommended height above cooking surface:
 min 26" for electric worktop
 min 30" for gas worktop

ELECTRICAL CONNECTION

The installation must be done through the use of a Junction Box.

Before making electrical connections to power supply, the electrical box must be secured in place as indicated

Power Supply Connection

For connection to the power supply refer to the follows:

- BLACK** = L line
- WHITE** = N neutral
- GREEN/YELLOW** = G ground

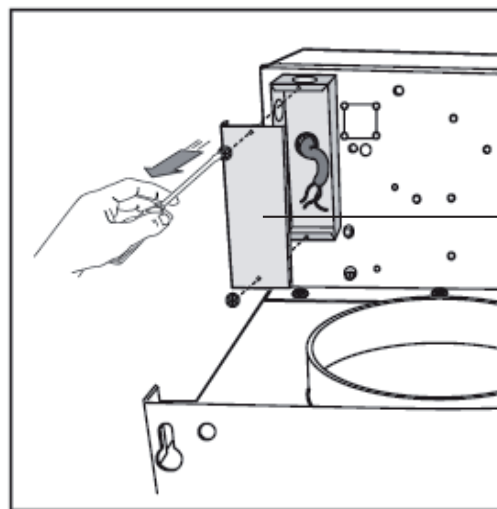
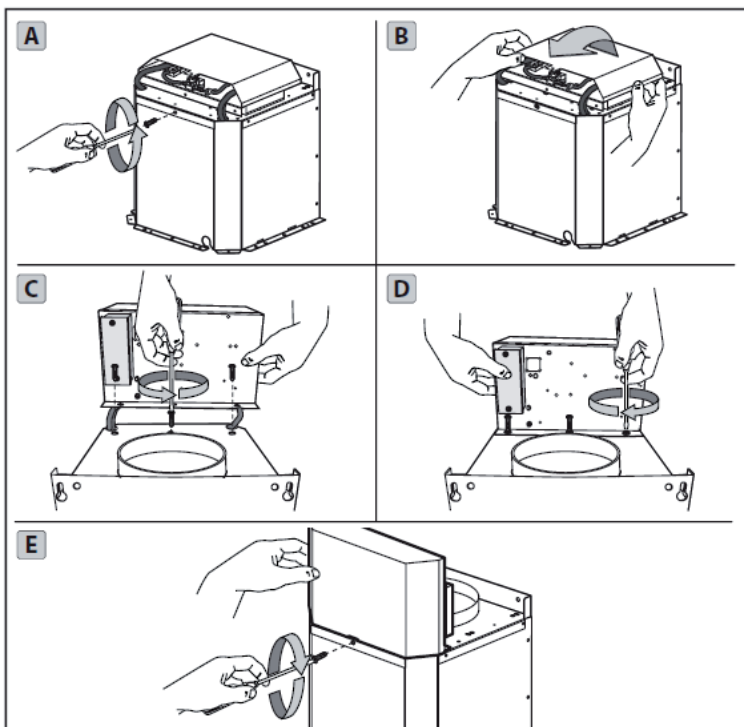

Wiring box cover

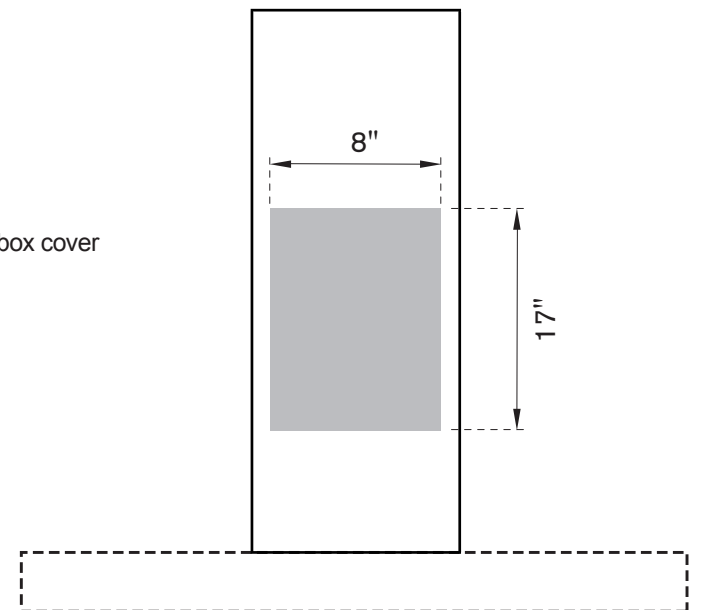

If the power cord to connect the hood to the main power comes from the wall in the grey area (8"x17"), it must have a minimum length of 20" to be connected to the Junction Box.