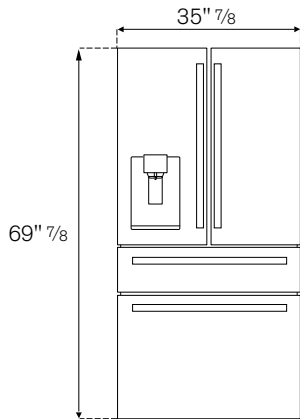
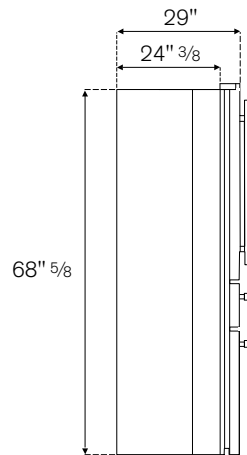
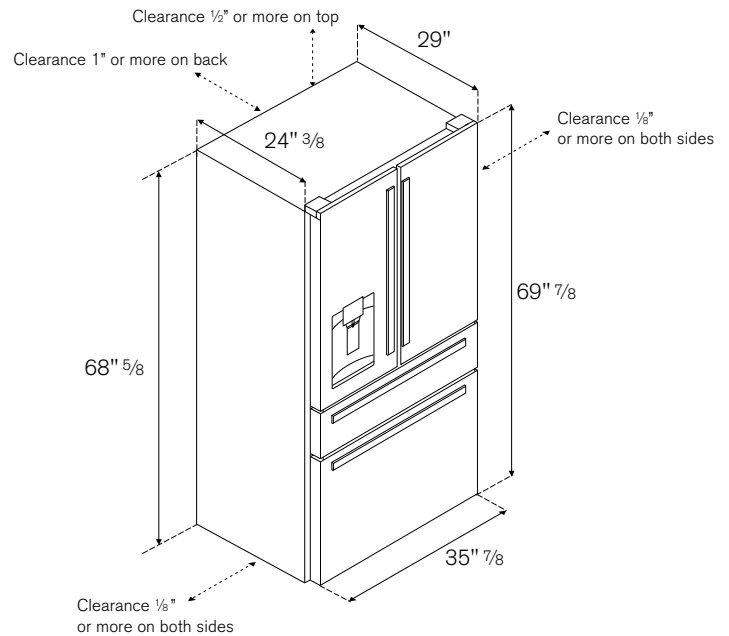
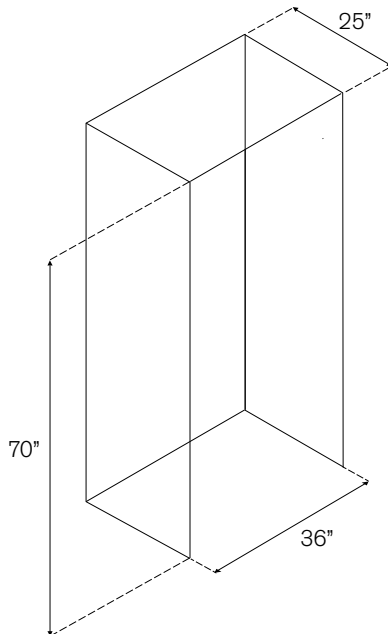
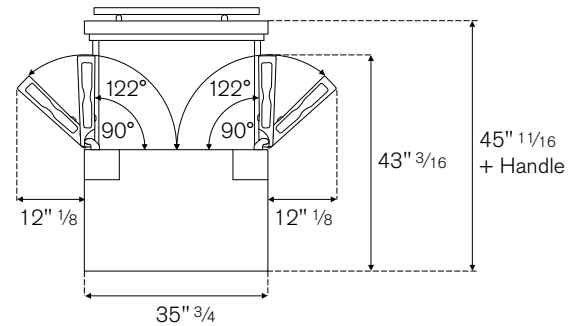
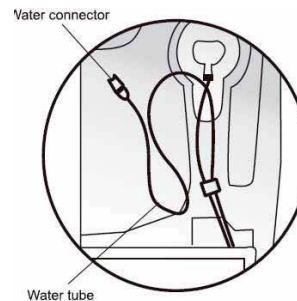
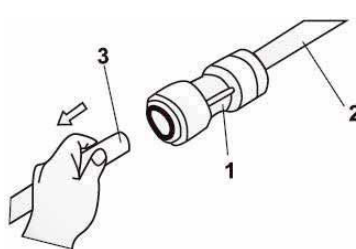
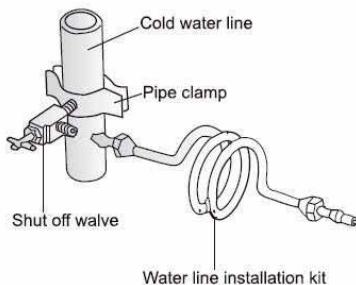

FRONT**SIDE****TOP**

WATER LINE INSTALLATION KITS: Available at extra cost from your dealer

**ELECTRICAL CONNECTION:**

A properly-grounded, electrical receptacle should be installed. A separate circuit breaker servicing only this appliance is recommended. Do not use a multi-purpose socket with other electrical appliances.

CONNECT WATER VALVE: Connect water supply line to water valve with accessible shutoff valve. Connect water line to refrigerator using installation kit. Kit includes one water tube and connector. Second water tube not supplied. Connect first water tube [2] into corresponding hole of water connector [1].