

REF36FDFIXNB

REFRIGERATOR 36" FREESTANDING FRENCH DOOR
STAINLESS STEEL FINISH



Energy Star rated refrigerator with 22.5 cu.ft capacity to handle the preservation needs of a large family.

Precise temperature and humidity control provided by dual air-cooling flow with independent no-frost system for refrigerator and freezer compartments.

Full-width temperature-controlled refrigeration drawer.

Dual humidity-controlled crispers to store and preserve separately fruit, vegetables and other produce.

Gallon-size door bins for practical organization of jars, cans, bottles and other quick reach items.

Foldable top shelf for storage of taller items in the refrigerator compartment.

Automatic ice-maker with automatic release and removable tray.

Super Freeze cycle option for 20% faster freezing performance.

Digital LED touch interface with user-friendly controls for temperature, super cool, super freeze and ice maker.

Overhead and sidewall LED lighting for clearer illumination.

Flat front stainless steel finish doors.

Channel handle design for doors and drawers.

2 years parts & labor warranty.

PRODUCT FEATURES

Size	W 36"
Volume	Ref 15.9 cu.ft / Frz 6.6 cu.ft
Door finish	Stainless steel look
User interface	Internal digital LED touch interface
Lighting	Top and sidewall LED lights
Refrigerator shelves	1 fixed and 4 height-adjustable, of which 1 retractable
Refrigerator crispers	1 large with preset temperature + 2 medium with adjustable humidity
Freezer compartment	2 drawers
Door storage	6 gallon sized bins
Ice maker	Automatic ice maker 3.08 lbs / 24h
Settings	Super cool, Super freeze, Ice maker

TECHNICAL SPECIFICATIONS

Electrical supply	115 V 60 HZ - 190 W - 2.5 Amp
Power connection	NEMA 5-15P with 67" power cord
Sound rating	45 dbA
Water connection	1/4" waterline with shut-off valve
Water supply pressure	MIN 0.15 MPa (1.5 Bar, 21.32 PSI) MAX 0.83 MPa (8.3 Bar, 120.96 PSI)
Energy consumption	588.0 kwh/yr
Certification	CEC, UL
Warranty	2 years parts & labor
Packaging dimensions	W 38 3/16" H 72 7/16" D 30 9/16"
Weight	298.0 lbs

ACCESSORIES

BHFDX	Bottle holder
-------	---------------



REF36FDFIXNB

REFRIGERATOR 36" FREESTANDING FRENCH DOOR
STAINLESS STEEL FINISH



FRONT

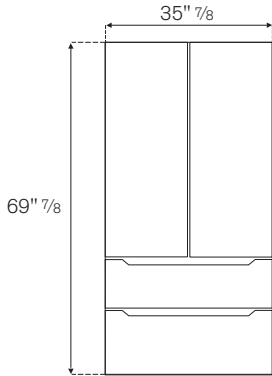

SIDE

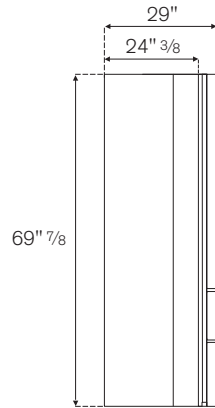

TOP

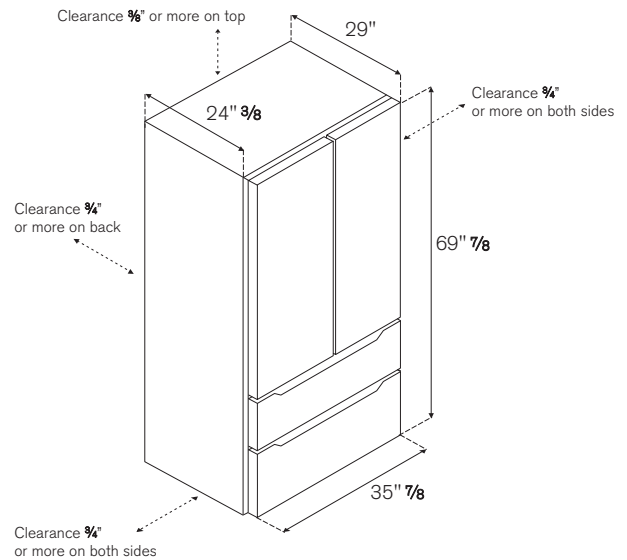
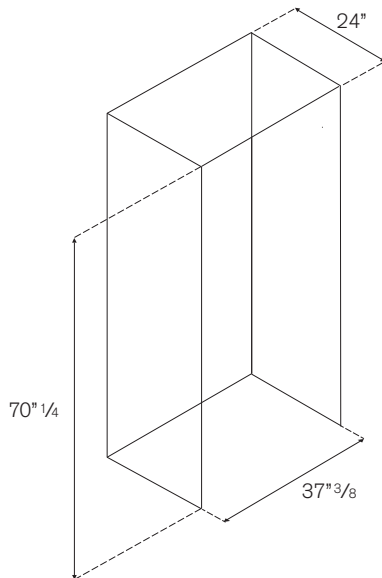
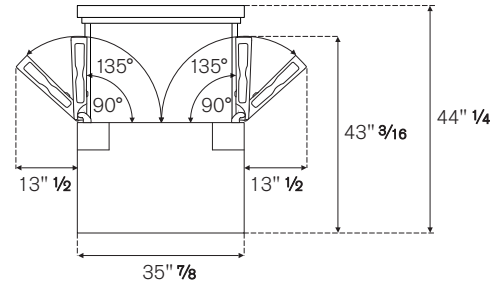

WATER LINE INSTALLATION KITS: Available at extra cost from your dealer

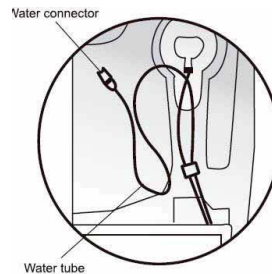
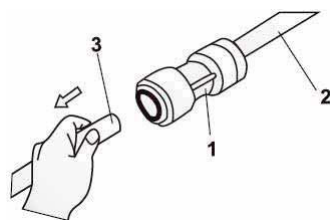
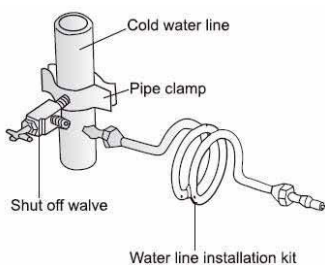

ELECTRICAL CONNECTION:

A properly-grounded, electrical receptacle should be installed. A separate circuit breaker servicing only this appliance is recommended. Do not use a multi-purpose socket with other electrical appliances.

CONNECT WATER VALVE: Connect water supply line to water valve with accessible shutoff valve. Connect water line to refrigerator using installation kit. Kit includes one water tube and connector. Second water tube not supplied. Connect first water tube [2] into corresponding hole of water connector[1].