

# MAS305DFMXV

MASTER SERIES DUAL-FUEL RANGE 30" - 5 BURNERS - ELECTRIC OVEN - STAINLESS STEEL FINISH



## Exclusive Finish and Materials

Metal knobs and handles make the range a standout in every kitchen. Stainless Toekick available as accessory. Optional Décor Sets knobs and handles in contrasting metals - satin gold and black nickel - for aesthetic customization.

## Bertazzoni signature counter-deep maintop

Bertazzoni signature stainless counter-deep maintop is designed to install flush with most kitchen countertops for a perfectly integrated look. Precise and flexible heating is generated through 5 Mono-bloc aluminum burners. The 19000 BTUs power burner with dual ring of flame boils water in 6 minutes flat. Complete the range with the optional cast-iron griddle.

## Extra large oven with dual convection

The 4.7 cu.ft electric main oven with dual horizontal convection allows even baking and roasting on 7 shelf levels. Bertazzoni ovens are equipped with an extra-large high-power broiler for broiling and grilling.

## Advanced programming and controls for the oven

The elegant temperature gauge for control of oven temperature during pre-heating and baking is a signature of every Bertazzoni range.

## Best-in-class features and design

The soft-motion oven door with edge-to-edge tempered glass is a masterpiece of European engineering and makes the oven door very easy to wipe clean. The stainless steel racks included with the range can be equipped with optional telescopic glides.

## GENERAL CHARACTERISTICS

Worktop	5 gas burners with lateral dual wok
Burners	Aluminum burners
Pan support	Cast iron
Upstand/Lid cover	1" stainless steel island trim
Knobs	Metal
Cooking modes	9
Tray	1 baking tray with grill trivet
Shelves	2 standard with handle
Levels	Laterals grids
Inner door	Squared 3 glasses
Door hinges	Soft motion
Legs	Stainless steel ø 2 3/8 inches

## TECHNICAL SPECIFICATIONS

Electrical requirements	120/208 V 60HZ - 2900W 120/240 V 60HZ - 3700W 20A
Warranty	2 years parts & labor
Packaging dimensions	H:42 1/8 W:33 7/8 D:29 15/16

# MAS305DFMXV

MASTER SERIES DUAL-FUEL RANGE 30" - 5 BURNERS - ELECTRIC OVEN - STAINLESS STEEL FINISH



## DIMENSIONS

### SIDE VIEW

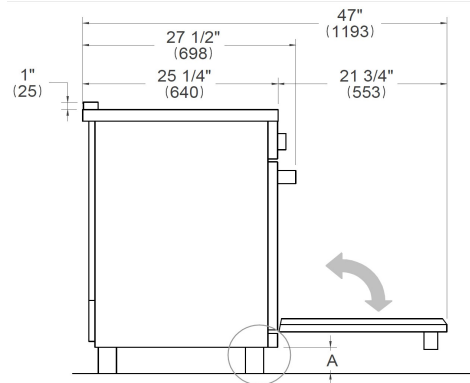

### LEG DETAILS

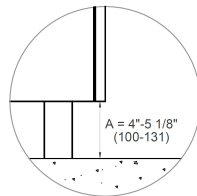

### FRONT VIEW

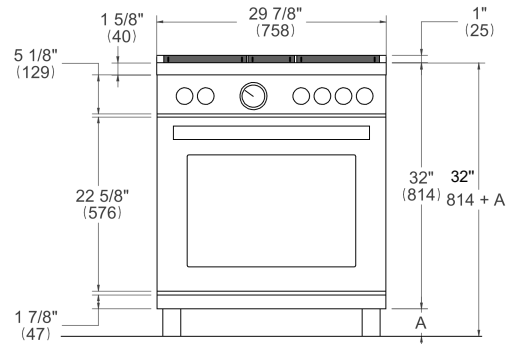

### WORKTOP DETAILS

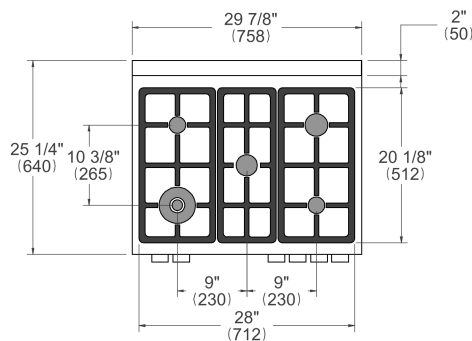

### REAR VIEW

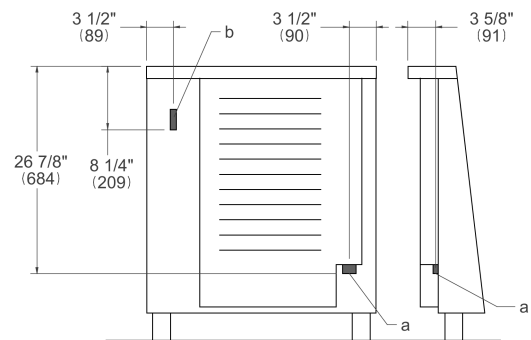

## INSTALLATION

**E** A properly-grounded horizontally mounted electrical receptacle should be installed no higher than 3" (7.6 cm) above the floor, no less than 2" (5 cm) and no more than 8" (20,3 cm) from the left side (facing product). Check all local code requirements.

**G** Install agency approved, properly sized manual shut-off valve at max. height of 3" from floor, 2" min. height/ 8" max. height from the right side (facing product). Use approved shut-off valve & regulator gas connection, properly sized flex or rigid pipe. Check all local code requirements.

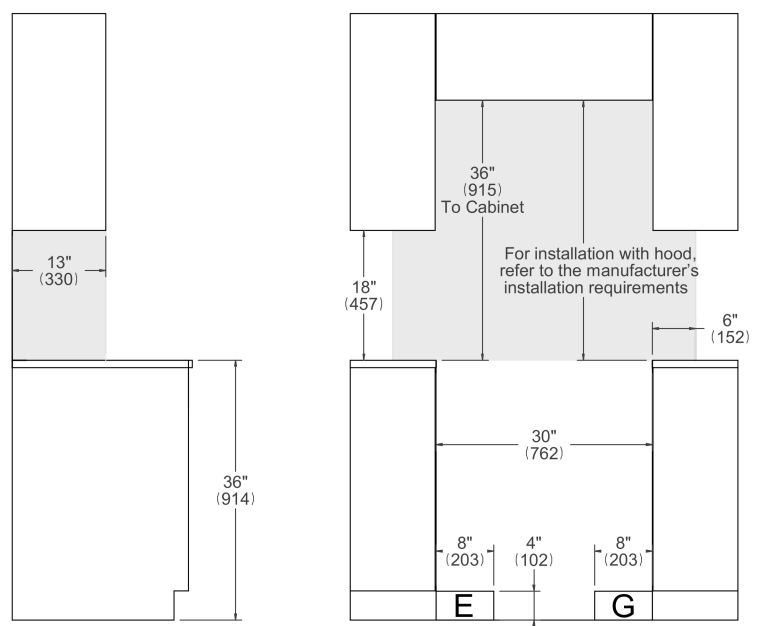

### NOTE

a. Electrical Connection  
b. Gas Connection

Disclaimer: while every effort has been made to insure the accuracy of the information contained in this document, Fratelli Bertazzoni reserves the right to change any part of the information at any time without notice. For detailed installation specifications consult the installation manual. Fratelli Bertazzoni, Bertazzoni and the winged wheel brand icon are registered trademarks of Bertazzoni Spa.