BERTAZZONI DESIGN SERIES

36" INDUCTION COOKTOPS P36 5 I X



This Bertazzoni touch control induction cooktop has a total output level of 13,600 W providing the fastest and most energy efficient way of cooking. Thanks to the booster function, the full energy becomes available instantaneously and is delivered directly to the cookware, thus eliminating inconvenient heat-up time. This Bertazzoni Design Series cooktop features 5 individually controlled induction heating zones and a sleek stainless steel framed low profile main top.

TOUCH CONTROL



The touch control interface provides the utmost in cooking flexibility.

LOW PROFILE STAINLESS STEEL TRIM



The induction top is framed by a low profile stainless trim.



TO COOK BEAUTIFULLY

BERTAZZONI DESIGN SERIES

36" INDUCTION COOKTOPS P36 5 I X

FEATURES

Induction (2x)	6 1/2" Diam. - 2200W
Induction (2x)	8 2/3" Diam. - 2800W
Induction (1x)	11" Diam. - 3600W

TECHNICAL SPECIFICATIONS

Electrical Requirements	208-240V 60Hz
Max. Amp Usage	50 Amp
Certification	CSA
Warranty	2 years parts and labor
Controls	Full touch
Product weight	61.7 lbs
Box weight	63.7 lbs

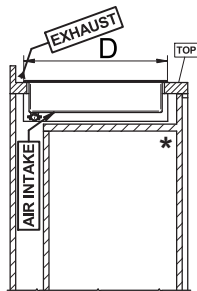
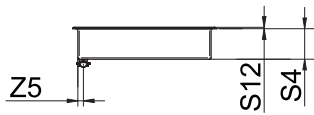
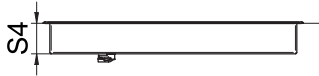
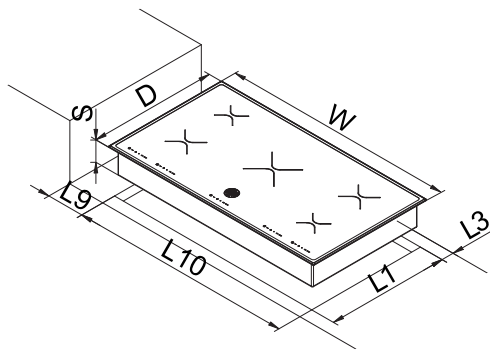

*This product cannot be installed over an under counter oven

DIMENSIONS

Ref.	Description	Dimensions	
		Inches	mm
D	Cooktop depth	20 ³ / ₈	518
L1	Cutout depth	19 1/2	496
L3 (min)	Cutout clearance from backwall	1 ⁹ / ₁₆	40
L9 (min)	Cutout clearance from cabinetry	6 ³ / ₈	162
L10	Cutout width	35 1/2	900
S	Cooktop height	4 ¹¹ / ₃₂	110
S4	Chassis height	4 ¹¹ / ₃₂	110
S12	Protruding glass thickness	⁷ / ₃₂	5
W	Cooktop width	36 ¹⁵ / ₁₆	938
Z5	Adjustable horizontal exit	²⁵ / ₃₂	20

INSTALLATION INSTRUCTIONS

Bertazzoni recommends to operate the appliance after it has been installed in a cabinet.

The kitchen cabinets shall be made of materials capable of withstanding temperatures at least 117°F (65°C) above room temperature in order to avoid possible damage to the cabinets during appliance usage. For further installation instructions refer to the installation manual.