BERTAZZONI PROFESSIONAL SERIES

24" SEGMENTED COOKTOP PM24 4 00 X



Bertazzoni sets the new standard in surface cooking flexibility with its new Professional Series Segmented cooktops. Housed in a sleek and sophisticated low profile stainless steel maintop, these new 24-inch cooktops are available in two gas burner configurations to perfectly match your own style of cooking. Combine one of these segmented cooktops with a Bertazzoni 24" wall oven for a compact high performance built-in solution, or upgrade your existing cooktop and elevate your cooking to the ultimate level.

KNOBS



Front-mounted knobs control reliable ignition systems with all the Bertazzoni safety feature.



TO COOK BEAUTIFULLY

BERTAZZONI PROFESSIONAL SERIES

24" SEGMENTED COOKTOP PM24 4 00 X

FEATURES

Aluminum burners	4
Rapid (1x)	11000 Btu/h
Semi-rapid (2x)	6500 Btu/h
Auxiliary (1x)	3400 Btu/h
Maintop	stainless steel
Worktop controls	knobs
Knobs	solid metal
Grates	cast iron
One hand ignition	yes

TECHNICAL SPECIFICATIONS

Electrical Requirements	120 V 60 Hz
Max Amp usage, power rating	1 A - 1 W
Certification	CSA
Warranty	2 years parts and labor

ACCESSORIES

A LP conversion kit for all burners is included

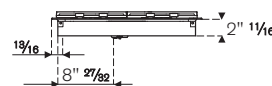
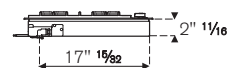
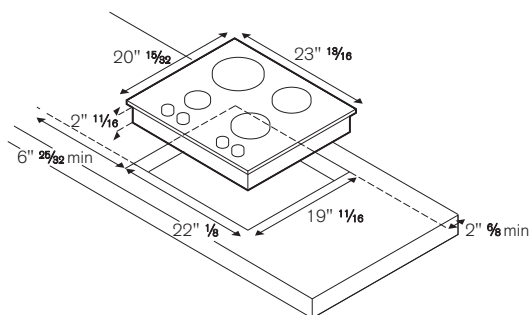

INSTALLATION INSTRUCTIONS

Bertazzoni recommends to operate the appliance after it has been installed in a cabinet.

The kitchen cabinets shall be made of materials capable of withstanding temperatures at least 117°F (65°C) above room temperature in order to avoid possible damage to the cabinets during appliance usage.

Disclaimer: while every effort has been made to insure the accuracy of the information contained in this brochure, Fratelli Bertazzoni reserves the right to change any part of the information at any time without notice.

Fratelli Bertazzoni, Bertazzoni and the winged wheel brand icon are registered trademarks of Bertazzoni Spa.

bertazzoni.com