

MODELS EB6 & EB9 EXTERNAL BLOWERS

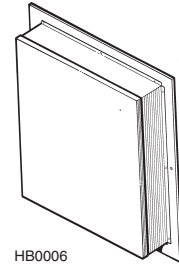

HB0006

Use this high-powered ventilator to quietly and efficiently exhaust airborne contaminants from cooking and living space.

FEATURES:

- Brushed aluminum construction
- Built-in flashing plate for roof or wall mount
- Built-in backdraft damper and birdscreen
- Easily removable cover provides quick access to blower for cleaning and servicing
- For 10" round duct – range hood mounting plate included
- Thermally protected, permanently lubricated motor
- Speed control compatible motor
- Neoprene resilient anti-vibration mounted motor
- Dynamically balanced 10¾" diameter blower wheel
- Low RPM - quiet operation
- For use with Best hoods and downdrafts designed to use external blowers

TYPICAL SPECIFICATION

Ventilator shall be a Best Model EB6 (Best Model EB9). Ventilator shall be roof (exterior wall) mountable with a 10" round duct connector.

Ventilator shall be of aluminum construction.

Ventilator shall include an automatic backdraft damper.

Air delivery shall be no less than 600 CFM (Model EB6), 900 CFM (Model EB9), as certified by HVI.

Note: To achieve reduced sound levels at the range hood, the external blower should be installed at least 10 feet away from the hood location and include one 90° elbow in the duct run between the hood and blower.



HVI-2100 CERTIFIED RATINGS comply with new testing technologies and procedures prescribed by the Home Ventilating Institute, for off-the-shelf products, as they are available to consumers. Product performance is rated at 0.1 in. static pressure, based on tests conducted in a state-of-the-art test laboratory. Sones are a measure of humanly-perceived loudness, based on laboratory measurements.

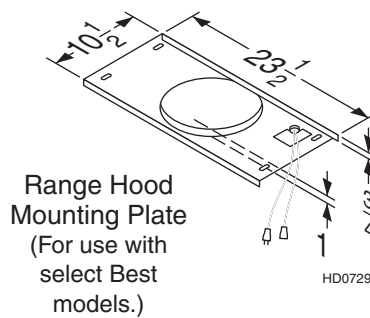

Range Hood Mounting Plate
(For use with select Best models.)

HD0729

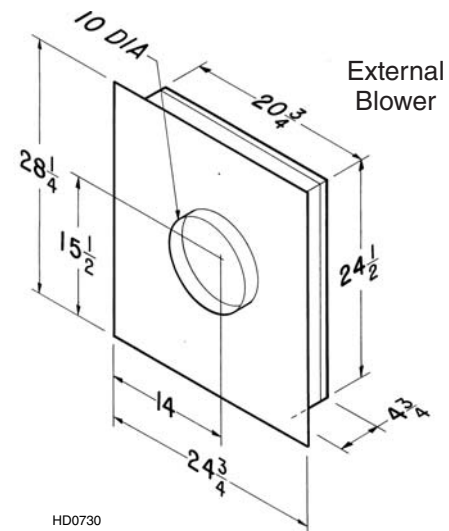

External Blower

HD0730

NOTE: DIMENSIONS SHOWN ARE IN INCHES

BEST Drummondville, QC, Canada www.BestRangeHoods.ca 866-737-7770

REFERENCE	QTY.	REMARKS	Project
			Location
			Architect
			Engineer
			Contractor
			Submitted by Date

SPECIFICATIONS & PERFORMANCE - Models EB6 & EB9

MODEL EB6

VOLTS	AMPS	CFM	DUCT
120	2.4	600	10" Round

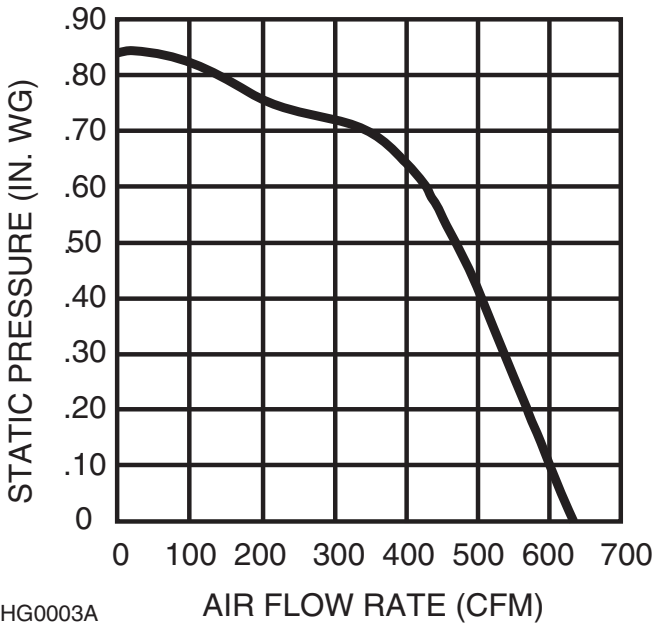

MODEL EB9

VOLTS	AMPS	CFM	DUCT
120	5.7	900	10" Round

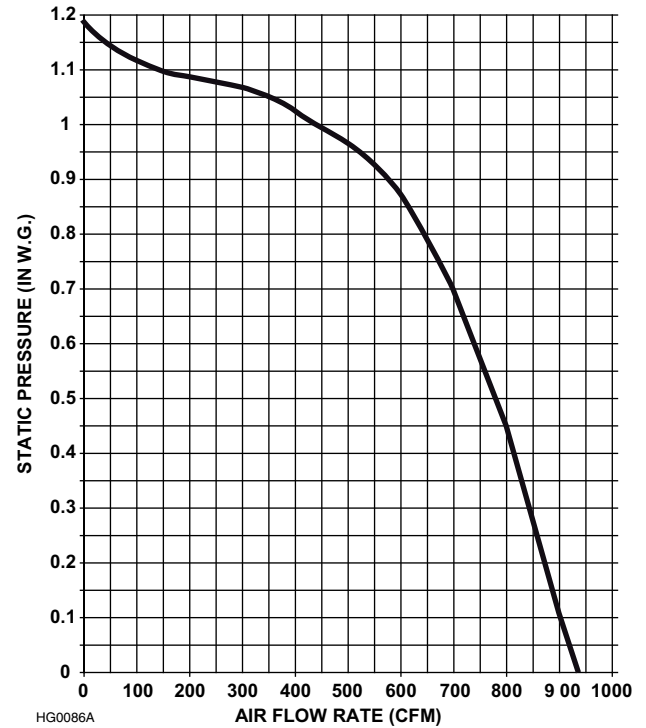

HG0003A

HG0086A



HVI-2100 CERTIFIED RATINGS comply with new testing technologies and procedures prescribed by the Home Ventilating Institute, for off-the-shelf products, as they are available to consumers. Product performance is rated at 0.1 in. static pressure, based on tests conducted in a state-of-the-art test laboratory. Sones are a measure of humanly-perceived loudness, based on laboratory measurements.

