

BRFB 1152 SS

11.7 cu. ft. (330 L) total gross volume
No frost



Fridge

- Chrome coated wine rack
- Bottle holder
- Illumination with white LED
- 3 safety glass shelves
- 4 door racks
- 2 egg trays
- Energy Star qualified

Freezer

- Auto defrost
- Ice cube tray
- Fast freeze function

Hygiene

- Antibacterial seal

Technical Information

- Dimensions (HxWxD) (cm): 184,5 x 59,5 x 60
- Dimensions (HxWxD) (in): 72 5/8 x 23 3/8 x 23 5/8*
- *Depth is without door handles.

Color

- BRFB 1152 SS: Fingerprint free stainless steel



Features



Frost free

Keeps food fresher for longer periods. Eliminates ice and bacteria build-up, avoids unpleasant fridge odors.



Hygiene+ antibacterial carbon filter

Photo catalyst carbon filter, eliminates bacteria, reduces fridge odour and ensures hygiene. The carbon filter can be reactivated easily, with just one day's exposure to sunlight.



Illumination with white LED

White LED provides a more aesthetic look inside your fridge and less energy consumption.



Fingerprint free

Fingerprint free inox for easy cleaning.

Blomberg[®]

seit 1883

BRFB 1152 SS

11.7 cu. ft. (330 L) total gross volume
No frost

MODEL CODE	BRFB 1152 SS
Type	Frost Free Bottom Freezer Refrigerator
Control system	Mechanic Control
Cooling system	FROST FREE
CAPACITIES	
Total net volume, cu.ft	9.8
L	279
Fresh food net volume, cu.ft	7.2
L	205
Freezer net volume, cu.ft	2.6
L	74
FRIDGE FEATURES	
Water dispenser	-
Electronic control display type	-
Auto defrost	•
Inner illumination	White LED
Shelves	3 safety glasses
Crispers	1
Door racks	4
Wine rack	•
Bottle gripper	•
Egg tray	2 x opaque / 6 egg holder
Fan ventilation	-
FREEZER FEATURES	
Auto defrost	•
Fast freeze function	•
Number of freezer drawers	3
Number of flaps	-
Automatic ice maker	-
Twist ice maker	-
Ice cube tray	•
HYGIENE	
Blue zone	-
hygAIR ionizing technology	-
Hygiene+ antibacterial carbon filter	-
Antibacterial seal	•
TECHNICAL INFORMATION	
Supply voltage, V/Hz	120 V / 60 Hz
Noise level, dBA	42
DIMENSIONS	
Unpacked (HxWxD), cm	184.5 x 59.5 x 60
Unpacked (HxWxD), in	72 5/8 x 23 3/8 x 23 5/8
Packed (HxWxD), cm	192.9 x 66.4 x 67.9
Packed (HxWxD), in	76 15/16 x 26 1/8 x 26 3/4
Product weight, kg	67.6
Product weight, lbs	148.7
Packed weight, kg	73.6
Packed weight, lbs	161.9
PERFORMANCE	
Energy Star qualified	•
ENERGY STAR® Most Efficient 2014	•
Climatic class	T
Annual energy consumption, kwh/year	355
Cooling gas	R134a
COLOR OPTIONS	
WH: White	-
SL: Silver	-
SS: Fingerprint free stainless steel	•
FFBI: Fully integrated	-

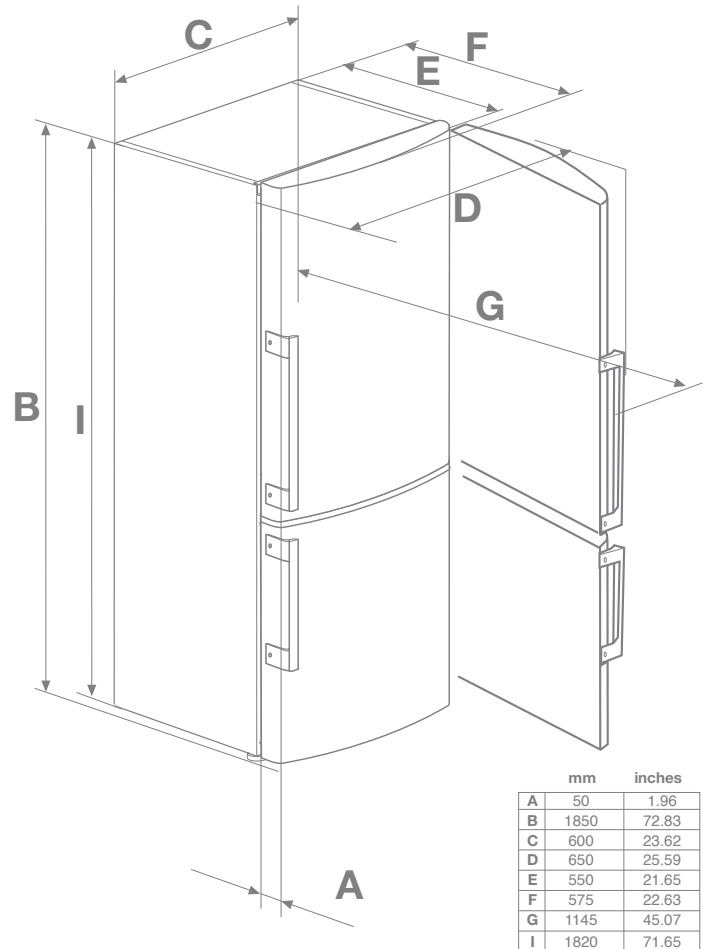

	mm	inches
A	50	1.96
B	1850	72.83
C	600	23.62
D	650	25.59
E	550	21.65
F	575	22.63
G	1145	45.07
I	1820	71.65