

# 30" Electric Slide-in Range

Benchmark™ Series – Stainless Steel HEIP054C



**HEIP054U**  
Stainless Steel

The newly designed full-depth electric slide-in range fits into any freestanding range cutout, and offers a flush built-in look.

## Features & Benefits

The new Bosch slide-in range fits in any freestanding range cutout.

Cook with a 6", 9" or 12" element.

Dampened hinges softly and quietly guide the SmoothClose door shut.

At 4.6 cu. ft., a large oven capacity accommodates most pots and pans.

A full-extension telescopic rack offers safe access to the oven cavity.

## General Properties

|               |   |
|---------------|---|
| Cooking modes | Meat Probe, Variable Broil (hi & low), Roast, Warm, Proof, Convection Bake, Convection Broil, Convection Roast, Pizza, True Convection/Convection Multi-Rack, Fast Preheat, Sabbath |
| Cleaning type | Self clean  |
| Knob material | Full metal  |
| Drawer type   | Warming drawer  |

## Oven Performance

|                              |         |
|------------------------------|---------|
| Bake element watts (W)       | 2,400 W |
| Broil element watts (W)      | 3,800 W |
| Convection element watts (W) | 2,000 W |

## Element Performance

|  |                         |
|--|-------------------------|
| Total number of cooktop elements       | 5                       |
| Power of front left element watts (W)  | 1,050 / 1,950 / 3,000 W |
| Power of back left element watts (W)   | 1,200 W                 |
| Power of centre element watts (W)      | 100 W                   |
| Power of back right element watts (W)  | 1,200 W                 |
| Power of front right element watts (W) | 1,100 / 3,200 W         |



## Element Size

|  |               |
|--|---------------|
| Dimension of front left heating element  | 6" / 9" / 12" |
| Dimension of back left heating element   | 6"            |
| Dimension of centre heating element      | 6"            |
| Dimension of back right heating element  | 6"            |
| Dimension of front right heating element | 9.5"          |

## Technical Details

|                     |          |
|---------------------|----------|
| Watts (W)           | 13,800 W |
| Circuit breaker (A) | 40 A     |
| Volts (V)           | 240 V    |
| Frequency (Hz)      | 60 Hz    |
| Plug type           | N/A      |
| Cord length         | N/A      |
| Energy source       | Electric |

## Dimensions & Weight

|  |                             |
|--|-----------------------------|
| Overall appliance dimensions (HxWxD) (in.) | 36 1/2" x 31 1/2" x 28 7/8" |
| Required cutout size (HxWxD) (in.)         | 35 1/2" x 30" x 25"         |
| Adjustable range height (in.)              | 1 1/2"                      |
| Net weight (lbs)                           | 248 lbs                     |

## Accessories—Included

Use and care manual, installation guide, mounting hardware, island trim, meat probe, standard racks, telescopic rack

## Accessories—Optional

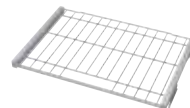

**HEZTR301**  
30" Telescopic rack



**HEZBS301**  
Low backguard

For help and assistance with Bosch accessories please call 1-800-944-2904 Mon-Fri 8am to 6pm EST

Notes: All height, width and depth dimensions are shown in inches. Please refer to installation instructions prior to making cutout. BSH reserves the absolute and unrestricted right to change product materials and specifications, at any time, without notice. Consult the product's installation instructions for final dimensional data and other details. Applicable product warranty can be found in accompanying product literature or you may contact your account manager for further details.

Warranties: Bosch warrants that the Product is free from defects in materials and workmanship for a period of three hundred and sixty-five (365) days from the date of purchase. The foregoing timeline begins to run upon the date of purchase, and shall not be stalled, tolled, extended, or suspended, for any reason whatsoever. This Product is also warranted to be free from cosmetic defects in material and workmanship (such as scratches of stainless steel, paint/porcelain blemishes, chip, dents, or other damage to the finish of the Product) for a period of thirty (30) days from the date of purchase or closing date for new construction. This cosmetic warranty excludes slight colour variations due to inherent differences in painted and porcelain parts, as well as differences caused by kitchen lighting, product location, or other similar factors. This cosmetic warranty specifically excludes any display, floor, "As Is", or "B" stock appliances.

For more information on our entire line of products, go to [www.bosch-home.ca](http://www.bosch-home.ca) or call 1-800-944-2904

© 2014 BSH Home Appliances Canada. All rights reserved. Bosch is a registered trademark of Robert Bosch GmbH.

# 30" Electric Slide-in Range

Benchmark™ Series – Stainless Steel HEIP054C



## Installation Details

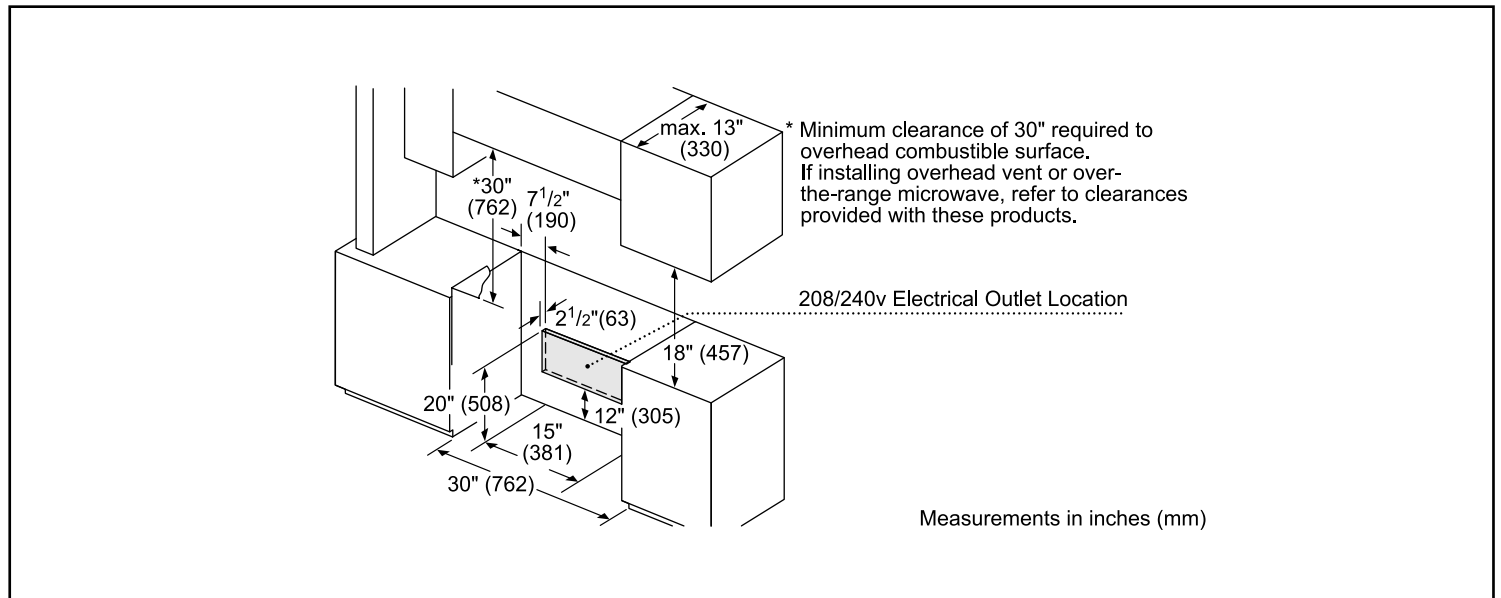
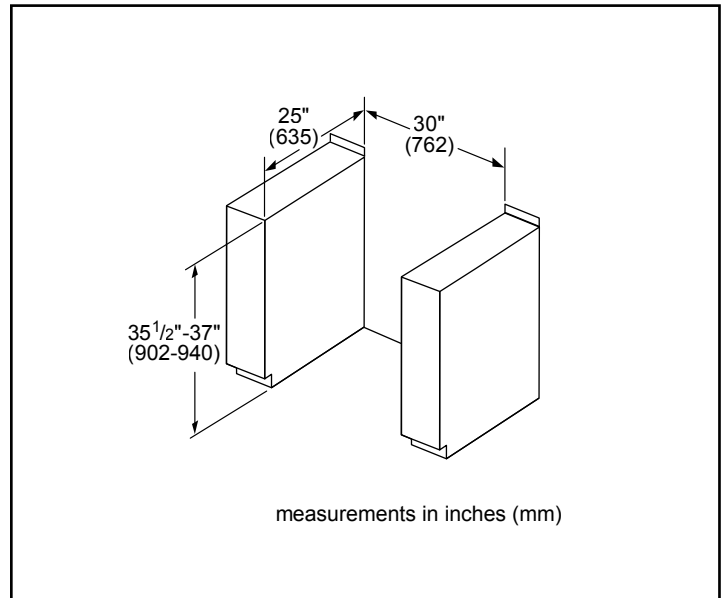
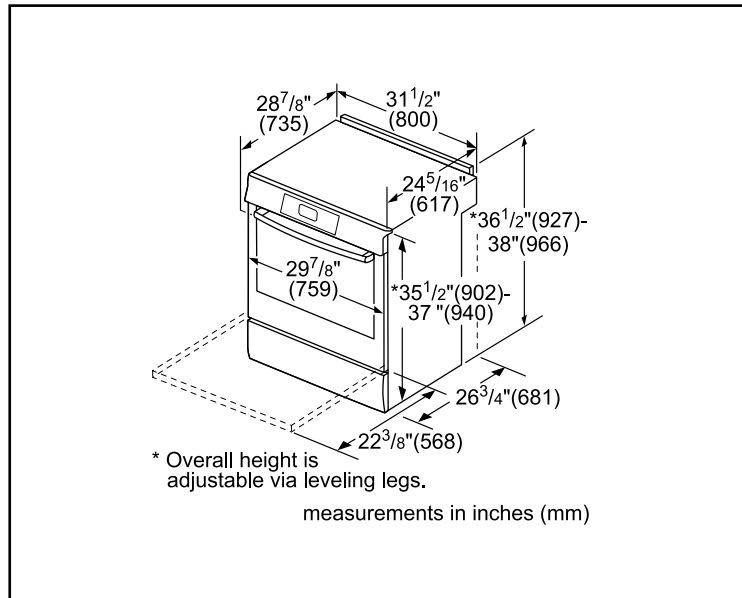

**For help and assistance with Bosch accessories please call 1-800-944-2904 Mon-Fri 8am to 6pm EST**

Notes: All height, width and depth dimensions are shown in inches. Please refer to installation instructions prior to making cutout. BSH reserves the absolute and unrestricted right to change product materials and specifications, at any time, without notice. Consult the product's installation instructions for final dimensional data and other details. Applicable product warranty can be found in accompanying product literature or you may contact your account manager for further details.

Warranties: Bosch warrants that the Product is free from defects in materials and workmanship for a period of three hundred and sixty-five (365) days from the date of purchase. The foregoing timeline begins to run upon the date of purchase, and shall not be stalled, tolled, extended, or suspended, for any reason whatsoever. This Product is also warranted to be free from cosmetic defects in material and workmanship (such as scratches of stainless steel, paint/porcelain blemishes, chip, dents, or other damage to the finish of the Product) for a period of thirty (30) days from the date of purchase or closing date for new construction. This cosmetic warranty excludes slight colour variations due to inherent differences in painted and porcelain parts, as well as differences caused by kitchen lighting, product location, or other similar factors. This cosmetic warranty specifically excludes any display, floor, "As Is", or "B" stock appliances.

**For more information on our entire line of products, go to [www.bosch-home.ca](http://www.bosch-home.ca) or call 1-800-944-2904**

© 2014 BSH Home Appliances Canada. All rights reserved. Bosch is a registered trademark of Robert Bosch GmbH.