

30" Dual Fuel Slide-in Range

800 Series – Stainless Steel HDI8054C



HDI8054U
Stainless Steel

The full-depth dual fuel slide-in range fits into any freestanding range cutout, and features five burners to cook more dishes at once.

Features & Benefits

The new Bosch slide-in range fits in any freestanding range cutout.

Powerful 18,000 BTU centre burner speeds cooking time.

At 4.6 cu. ft., a large oven capacity accommodates most pots and pans.

Genuine European convection for even baking results on multiple levels.

The warming drawer keeps everything you cook warm and ready to serve.

General Properties

Cooking modes	Meat Probe, Variable Broil (hi & low), Roast, Warm, Proof, Convection Bake, Convection Broil, Convection Roast, Pizza, True Convection/Convection Multi-Rack, Fast Preheat, Sabbath
Cleaning type	Self clean
Type of grate	Cast iron
Knob material	Full metal
Drawer type	Warming drawer
Sealed burners	Yes

Oven Performance

Bake element watts (W)	2,400 W
Broil element watts (W)	3,800 W
Convection element watts (W)	2,000 W

Burner Performance

Total number of cooktop burners	5
Total connection rating (NG / LP) BTU	53,000 / 44,000
Power of front left burner (NG / LP) BTU	10,000 / 8,000
Power of back left burner (NG / LP) BTU	5,000 / 5,000
Power of centre burner (NG / LP) BTU	18,000 / 12,500
Power of back right burner (NG / LP) BTU	5,000 / 5,000
Power of front right burner (NG / LP) BTU	15,000 / 13,000

Technical Details

Watts (W)	5,100 W
Circuit breaker (A)	30 A
Volts (V)	240 V
Frequency (Hz)	60 Hz
Plug type	N/A
Cord length	N/A
Energy source	Mixed Electric / Gas
Gas type	Natural gas 15 mbar (USA)
Alternative gas type	LP 27, 5 mbar (USA)

Dimensions & Weight

Overall appliance dimensions (HxWxD) (in.)	36 1/2" x 31 1/2" x 28 7/8"
Required cutout size (HxWxD) (in.)	35 1/2" x 30" x 25"
Adjustable range height (in.)	1 1/2"
Net weight (lbs)	243 lbs

Accessories—Included

Use and care manual, installation guide, mounting hardware, island trim, meat probe, LP conversion kit, standard racks

Accessories—Optional



HEZTR301
30" Telescopic rack



HGZBS301
Low backguard



HEZGR301
Griddle



HEZ298102
Wok ring



For help and assistance with Bosch accessories please call 1-800-944-2904 Mon-Fri 8am to 6pm EST

Notes: All height, width and depth dimensions are shown in inches. Please refer to installation instructions prior to making cutout. BSH reserves the absolute and unrestricted right to change product materials and specifications, at any time, without notice. Consult the product's installation instructions for final dimensional data and other details. Applicable product warranty can be found in accompanying product literature or you may contact your account manager for further details.

Warranties: Bosch warrants that the Product is free from defects in materials and workmanship for a period of three hundred and sixty-five (365) days from the date of purchase. The foregoing timeline begins to run upon the date of purchase, and shall not be stalled, tolled, extended, or suspended, for any reason whatsoever. This Product is also warranted to be free from cosmetic defects in material and workmanship (such as scratches of stainless steel, paint/porcelain blemishes, chip, dents, or other damage to the finish of the Product) for a period of thirty (30) days from the date of purchase or closing date for new construction. This cosmetic warranty excludes slight colour variations due to inherent differences in painted and porcelain parts, as well as differences caused by kitchen lighting, product location, or other similar factors. This cosmetic warranty specifically excludes any display, floor, "As Is", or "B" stock appliances.

For more information on our entire line of products, go to www.bosch-home.ca or call 1-800-944-2904

© 2014 BSH Home Appliances Canada. All rights reserved. Bosch is a registered trademark of Robert Bosch GmbH.

30" Dual Fuel Slide-in Range

800 Series – Stainless Steel HDI8054C



Installation Details

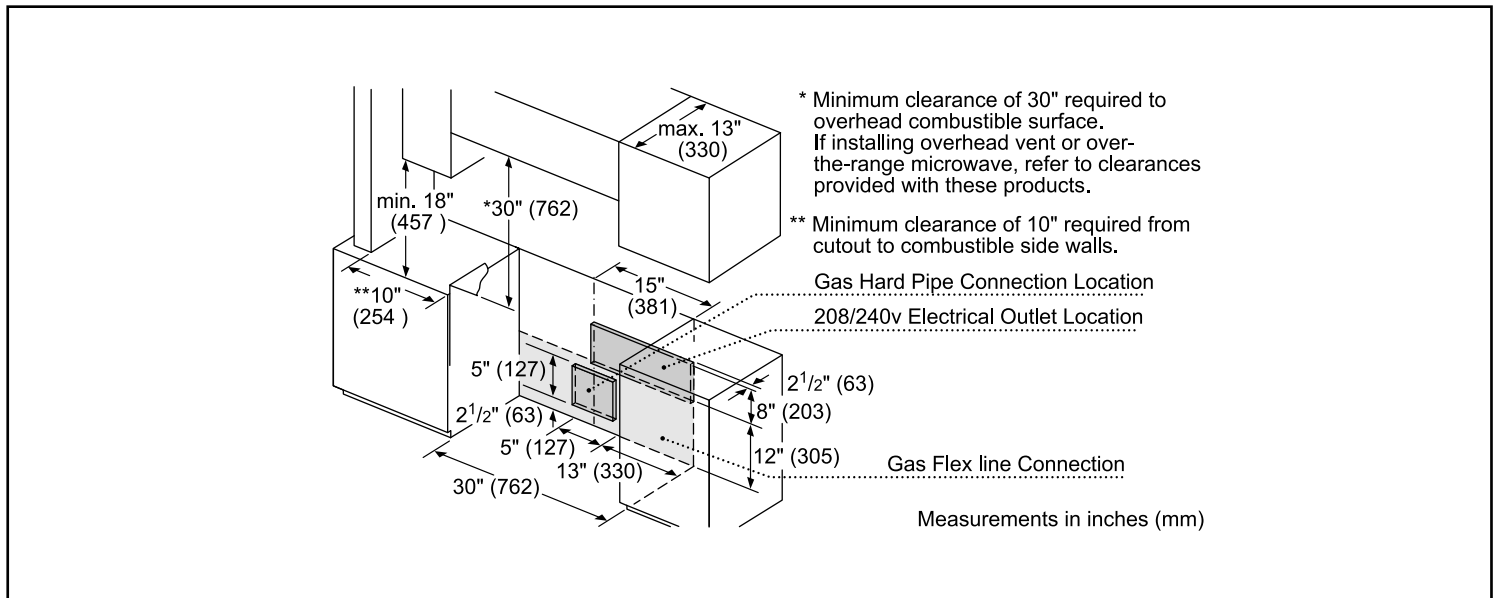
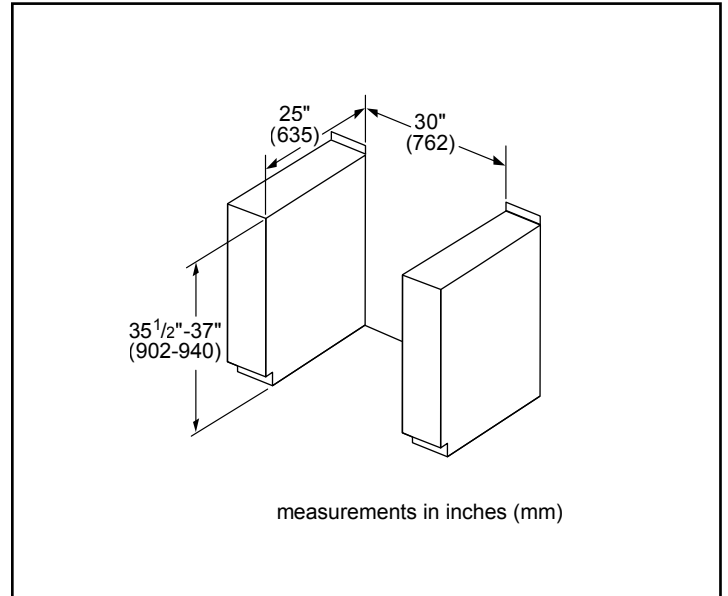
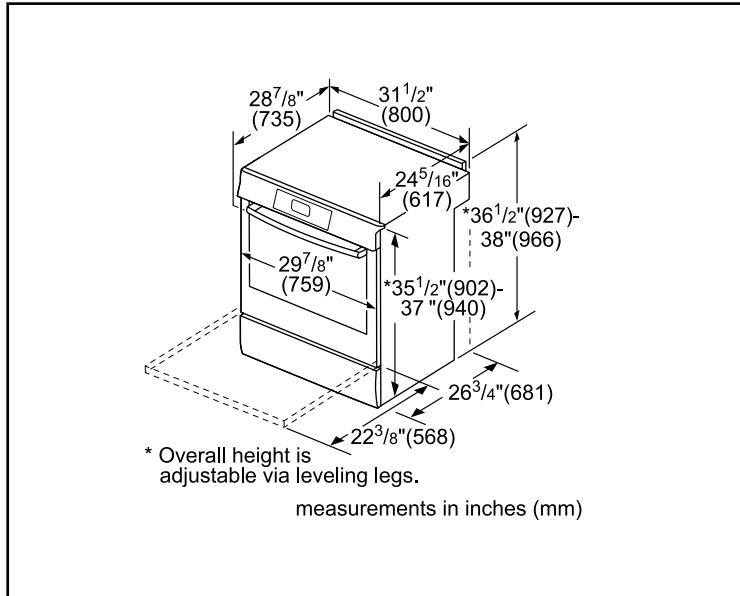

For help and assistance with Bosch accessories please call 1-800-944-2904 Mon-Fri 8am to 6pm EST

Notes: All height, width and depth dimensions are shown in inches. Please refer to installation instructions prior to making cutout. BSH reserves the absolute and unrestricted right to change product materials and specifications, at any time, without notice. Consult the product's installation instructions for final dimensional data and other details. Applicable product warranty can be found in accompanying product literature or you may contact your account manager for further details.

Warranties: Bosch warrants that the Product is free from defects in materials and workmanship for a period of three hundred and sixty-five (365) days from the date of purchase. The foregoing timeline begins to run upon the date of purchase, and shall not be stalled, tolled, extended, or suspended, for any reason whatsoever. This Product is also warranted to be free from cosmetic defects in material and workmanship (such as scratches of stainless steel, paint/porcelain blemishes, chip, dents, or other damage to the finish of the Product) for a period of thirty (30) days from the date of purchase or closing date for new construction. This cosmetic warranty excludes slight colour variations due to inherent differences in painted and porcelain parts, as well as differences caused by kitchen lighting, product location, or other similar factors. This cosmetic warranty specifically excludes any display, floor, "As Is", or "B" stock appliances.

For more information on our entire line of products, go to www.bosch-home.ca or call 1-800-944-2904

© 2014 BSH Home Appliances Canada. All rights reserved. Bosch is a registered trademark of Robert Bosch GmbH.