

30" Dual Fuel Slide-in Range

Benchmark® Series – Stainless Steel HDIP054C



HDIP054C
Stainless Steel

The full-depth dual fuel slide-in range fits into any freestanding range cutout, and offers a powerful dual-stacked burner.

Features & Benefits

Genuine European Convection for even baking results on multiple racks.

Powerful 20,000 BTU dual-stacked center burner designed for faster boiling and low simmer.

Dampened hinges softly and quietly guide the QuietClose® door shut.

A full-extension telescopic rack offers safe access to the oven cavity.

The warming drawer keeps everything you cook warm and ready to serve.



General Properties

Cooking modes	Bake, Variable Broil (hi & low), Roast, Warm, Proof Dough, Convection Bake, Convection Broil, Convection Roast, Multi-Rack Genuine European Convection, Convection Conversion, Pizza, Temperature Probe, Fast Preheat, Sabbath
Cleaning type	Self clean
Type of grate	Cast iron
Knob material	Metal
Drawer type	Warming drawer
Sealed burners	Yes

Oven Performance

Bake / broil element watts (W)	2,400 / 3,800 W
Convection element watts (W)	2,000 W

Burner Performance

Total number of cooktop burners	5
Total cooktop (NG / LP) BTU	55,000 / 48,500
Power of front left burner (NG / LP) BTU	10,000 / 8,000
Power of back left burner (NG / LP) BTU	5,000 / 5,000
Power of center burner (NG / LP) BTU	20,000 / 17,000
Power of back right burner (NG / LP) BTU	5,000 / 5,000
Power of front right burner (NG / LP) BTU	15,000 / 13,500

Technical Details

Watts (W)	4,800 / 6,400 W
Circuit breaker (A)	30 A
Volts (V)	208 V / 240 V
Frequency (Hz)	60 Hz
Plug type	N/A
Cord length (in.)	N/A
Energy source	Mixed Electric / Gas
Gas type	Natural gas 15 mbar (USA)
Alternative gas type	LP 27, 5 mbar (USA)

Dimensions & Weight

Overall appliance dimensions (HxWxD)(in.)	36 1/2" x 31 1/2" x 29 1/6"
Required cutout size (HxWxD) (in.)	35 1/2" x 30" x 25 1/8"
Adjustable range height (in.)	1 1/2"
Overall oven interior dimensions (HxWxD)(in.)	17 13/16" x 24 1/8" x 18"
Usable oven interior dimensions (HxWxD)(in.)	12 5/16" x 23 1/4" x 15 1/4"
Net weight (lbs)	243 lbs

Accessories—Included

Use and care manual, installation guide, temperature probe, LP conversion kit, standard racks, telescopic rack

Accessories—Optional



HEZ298102
Wok ring



HEZGR301
Griddle

HDZIT301
Island Trim

HDZBS301
4" Low backguard

For help and assistance with Bosch accessories please call 1-800-944-2904 Mon-Fri 8am to 6pm EST

Notes: All height, width and depth dimensions are shown in inches. BSH reserves the absolute and unrestricted right to change product materials and specifications, at any time, without notice. Consult the product's installation instructions for final dimensional data and other details prior to making cutout. Applicable product warranty can be found in accompanying product literature or you may contact your account manager for further details.

Warranties: Bosch warrants that the Product is free from defects in materials and workmanship for a period of three hundred and sixty-five (365) days from the date of purchase. The foregoing timeline begins to run upon the date of purchase, and shall not be stalled, tolled, extended, or suspended, for any reason whatsoever. This Product is also warranted to be free from cosmetic defects in material and workmanship (such as scratches of stainless steel, paint/porcelain blemishes, chip, dents, or other damage) to the finish of the Product, for a period of thirty (30) days from the date of purchase or closing date for new construction. This cosmetic warranty excludes slight color variations due to inherent differences in painted and porcelain parts, as well as differences caused by kitchen lighting, product location, or other similar factors. This cosmetic warranty specifically excludes any display, floor, "As Is", or "B" stock appliances.

For more information on our entire line of products, go to www.bosch-home.ca or call 1-800-944-2904

© BSH Home Appliances Limited. All rights reserved. Bosch is a registered trademark of Robert Bosch GmbH.

09/15

30" Dual Fuel Slide-in Range

Benchmark® Series – Stainless Steel HDIP054C



Installation Details

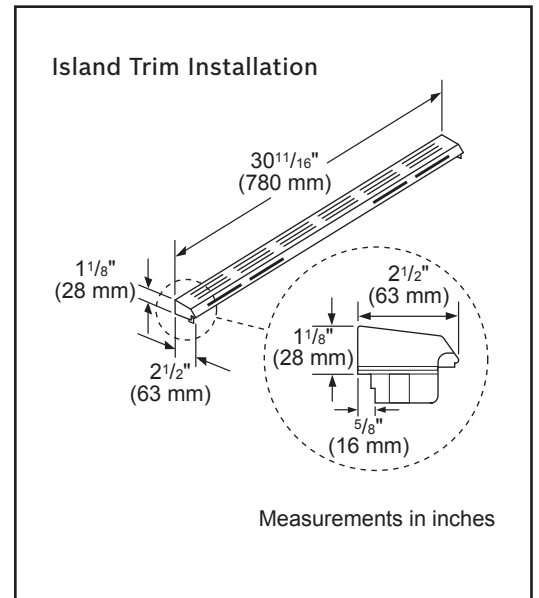
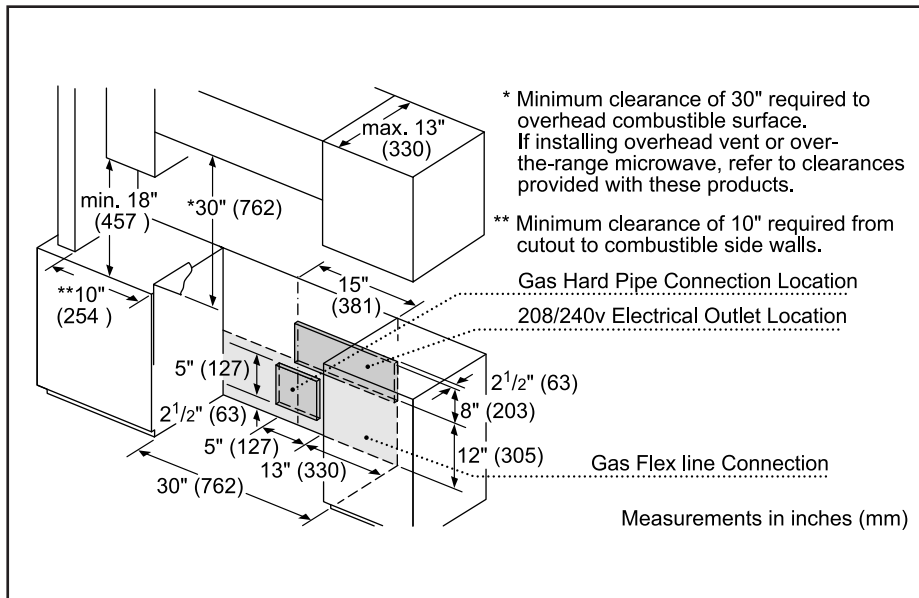
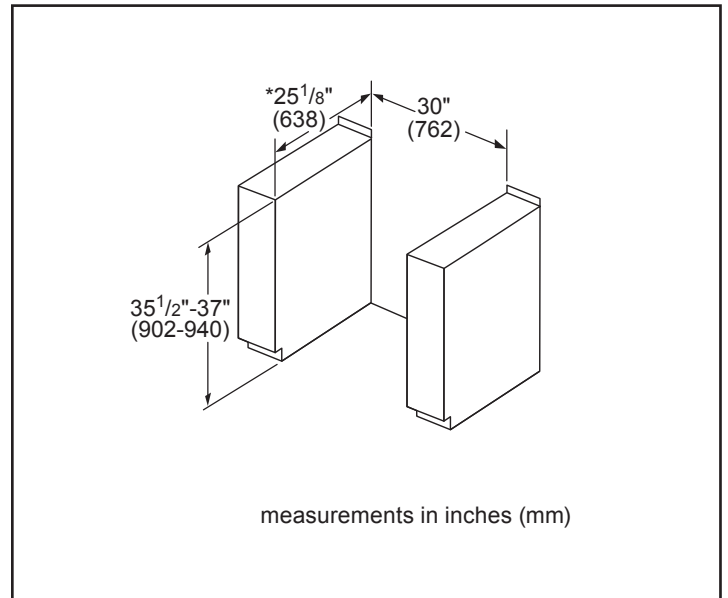
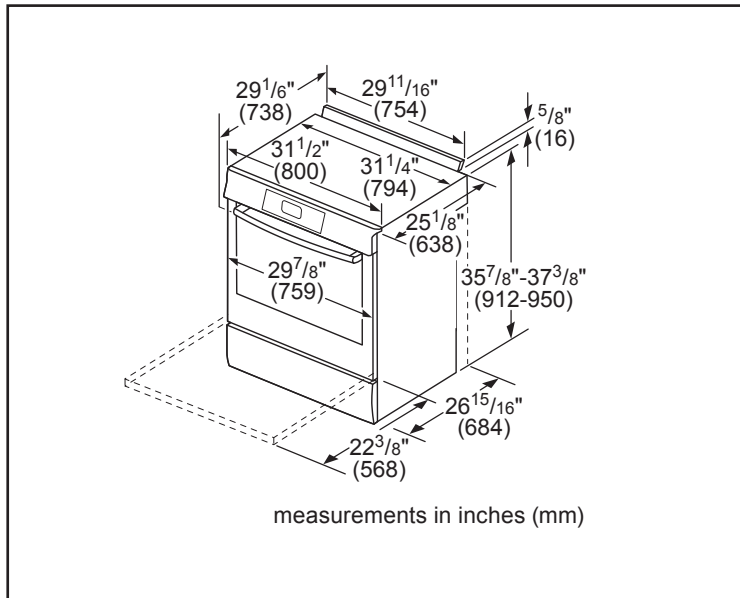

For help and assistance with Bosch accessories please call 1-800-944-2904 Mon-Fri 8am to 6pm EST

Notes: All height, width and depth dimensions are shown in inches. BSH reserves the absolute and unrestricted right to change product materials and specifications, at any time, without notice. Consult the product's installation instructions for final dimensional data and other details prior to making cutout. Applicable product warranty can be found in accompanying product literature or you may contact your account manager for further details.

Warranties: Bosch warrants that the Product is free from defects in materials and workmanship for a period of three hundred and sixty-five (365) days from the date of purchase. The foregoing timeline begins to run upon the date of purchase, and shall not be stalled, tolled, extended, or suspended, for any reason whatsoever. This Product is also warranted to be free from cosmetic defects in material and workmanship (such as scratches of stainless steel, paint/porcelain blemishes, chip, dents, or other damage) to the finish of the Product, for a period of thirty (30) days from the date of purchase or closing date for new construction. This cosmetic warranty excludes slight color variations due to inherent differences in painted and porcelain parts, as well as differences caused by kitchen lighting, product location, or other similar factors. This cosmetic warranty specifically excludes any display, floor, "As Is", or "B" stock appliances.

For more information on our entire line of products, go to www.bosch-home.ca or call 1-800-944-2904

© BSH Home Appliances Limited. All rights reserved. Bosch is a registered trademark of Robert Bosch GmbH.

09/15