

# 24" Compact Condensation Dryer

500 Series – WTG86401UC



**WTG86401UC**  
White

The 500 series washer & dryer are one of the few ENERGY STAR® qualified 24" pairs offering quality, water protection & design.

## Features & Benefits

Only ENERGY STAR® dryer in 24" compact laundry market.

Bosch washers and dryers are the only ENERGY STAR® 24" laundry pair.

Condensation drying doesn't require ducting.

Perfect design match to Bosch 500 series washer.

Washer plugs into dryer for easy installation.

Dry up to 18 towels in one load.



## General Properties

Dryer type	Condensing
Drum material	Stainless Steel
Interior light	No
Ventless drying (no ducting)	Yes
Stackable	Yes
Silence level (dBA)	65
Programs (No.), [Special]	(15), [Bulky/Large Items, Towels]
Options (No.), [Special]	(6), [Dry Level, Finished In]
Energy consumption (kWh/yr)	311
ENERGY STAR® qualified	Yes

## Capacity

Capacity (cu. ft.)	4.0
Relative load	18 bath towels

## Design Elements

Door ring	Silver
Control type	Touch
Dial	Silver ring with white center
Bosch logo on door glass	Yes

## Technical Details

Energy source	Electric
Watts (W)	2,800
Circuit breaker (A)	30
Volts (V)	208/220-240
Current (A)	13
Frequency (Hz)	60
Plug type	240V; NEMA 14-30 (4 prong)

## Technical Details (Continued)

Power cord included	Yes
Power cord length (in)	63 (Full Length)
Drain hose length (in)	78 (Full Length)
Door hinge	Right Side (Reversible)

## Dimensions & Weight

Overall appliance dimensions (HxWxD)(in)	33 1/4" x 23 1/2" x 25"
Net weight (lbs)	99 lbs
Minimum stack height (in)	67 3/4"

## ADA compliance

- Meets ADA height and access requirements *when installed on pedestal.*
- Meets ADA operable parts requirements for controls and lint filter.

## Accessories—Optional



**WTZ11400**  
Stacking kit with shelf



**WTZ20410**  
Stacking kit without shelf



**WMZ20500**  
Pedestal



**WMZ20600**  
Drying Rack



For help and assistance with Bosch accessories please call 1-800-944-2904 Mon-Fri 8am to 6pm EST

Notes: All height, width and depth dimensions are shown in inches. BSH reserves the absolute and unrestricted right to change product materials and specifications, at any time, without notice. Consult the product's installation instructions for final dimensional data and other details prior to making cutout. Applicable product warranty can be found in accompanying product literature or you may contact your account manager for further details.

Warranties: Bosch warrants that the Product is free from defects in materials and workmanship for a period of three hundred and sixty-five (365) days from the date of purchase. The foregoing timeline begins to run upon the date of purchase, and shall not be stalled, tolled, extended, or suspended, for any reason whatsoever. This Product is also warranted to be free from cosmetic defects in material and workmanship (such as scratches of stainless steel, paint/porcelain blemishes, chip, dents, or other damage) to the finish of the Product, for a period of thirty (30) days from the date of purchase or closing date for new construction. This cosmetic warranty excludes slight color variations due to inherent differences in painted and porcelain parts, as well as differences caused by kitchen lighting, product location, or other similar factors. This cosmetic warranty specifically excludes any display, floor, "As Is", or "B" stock appliances.

For more information on our entire line of products, go to [www.bosch-home.ca](http://www.bosch-home.ca) or call 1-800-944-2904

© BSH Home Appliances Limited. All rights reserved. Bosch is a registered trademark of Robert Bosch GmbH.

# 24" Compact Condensation Dryer

500 Series – WTG86401UC



## Installation Details

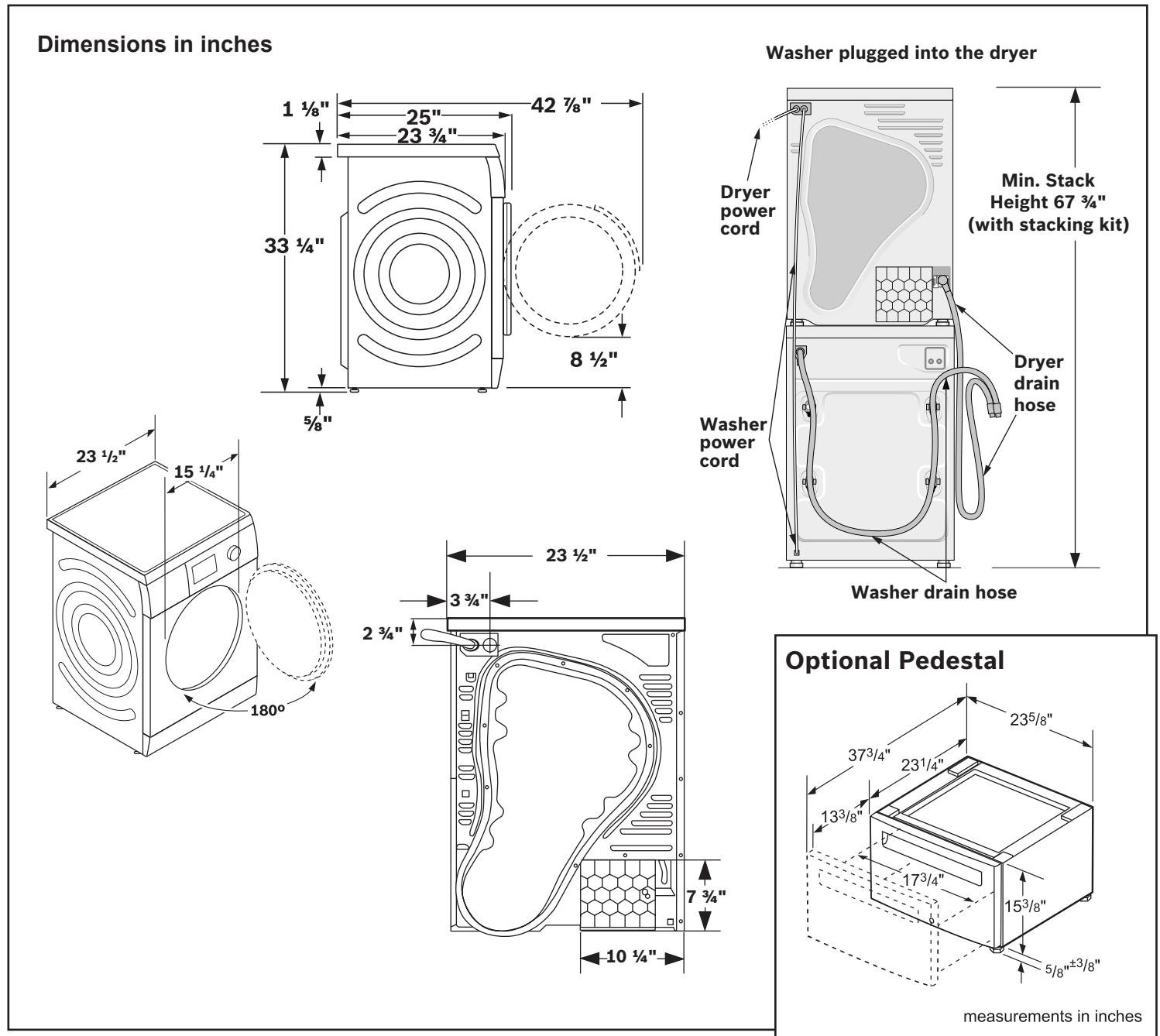

For help and assistance with Bosch accessories please call 1-800-944-2904 Mon-Fri 8am to 6pm EST

Notes: All height, width and depth dimensions are shown in inches. BSH reserves the absolute and unrestricted right to change product materials and specifications, at any time, without notice. Consult the product's installation instructions for final dimensional data and other details prior to making cutout. Applicable product warranty can be found in accompanying product literature or you may contact your account manager for further details.

Warranties: Bosch warrants that the Product is free from defects in materials and workmanship for a period of three hundred and sixty-five (365) days from the date of purchase. The foregoing timeline begins to run upon the date of purchase, and shall not be stalled, tolled, extended, or suspended, for any reason whatsoever. This Product is also warranted to be free from cosmetic defects in material and workmanship (such as scratches of stainless steel, paint/porcelain blemishes, chip, dents, or other damage) to the finish of the Product, for a period of thirty (30) days from the date of purchase or closing date for new construction. This cosmetic warranty excludes slight color variations due to inherent differences in painted and porcelain parts, as well as differences caused by kitchen lighting, product location, or other similar factors. This cosmetic warranty specifically excludes any display, floor, "As Is", or "B" stock appliances.

For more information on our entire line of products, go to [www.bosch-home.ca](http://www.bosch-home.ca) or call 1-800-944-2904

© BSH Home Appliances Limited. All rights reserved. Bosch is a registered trademark of Robert Bosch GmbH.

09/15

# 24" Compact Condensation Dryer

500 Series – WTG86401UC



## Installation Details

Closet: Stacked

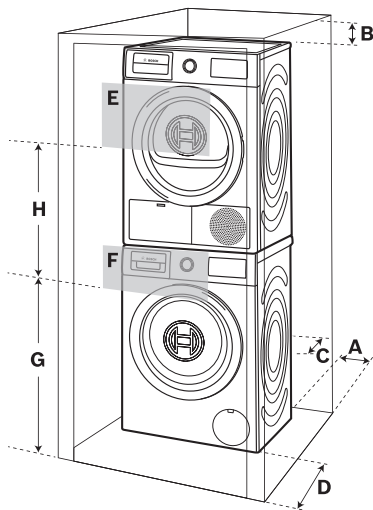

Closet: Stand Alone (shown) or Side by Side

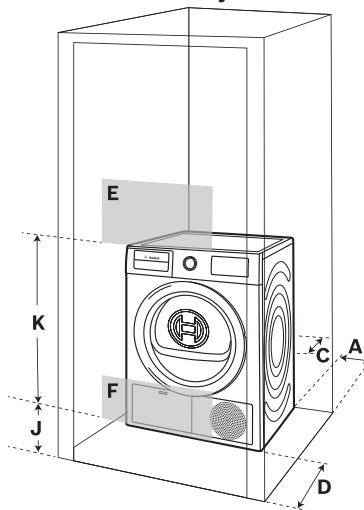

### Clearance requirements (Minimum)

A Both Sides	5/8 in.
B Top	6 1/4 in.
C Rear	2 1/2 in.
D Front	2 1/2 in.

### Ventilation Area (Minimum)

E Top	63 sq. in.
F Bottom	63 sq. in.

### Vent Spacing

G	37 in.
H	26 in.
J	3 in.
K	29 in.

## Enclosure Dimensions

Under Counter: (Preferred)

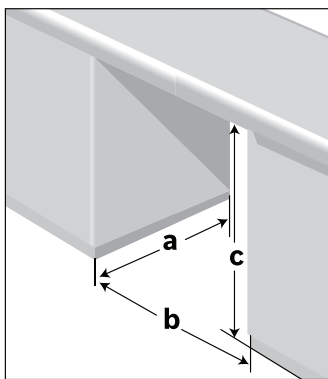

Front of the appliance fully open. No doors or coverings.

Under Counter: (Less Preferred)

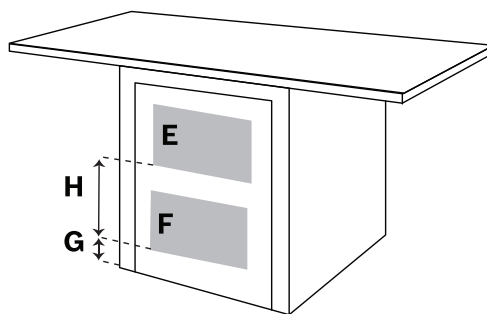

If the front of the appliance is covered, ventilation openings must be installed as shown and front/rear clearances adhered to according to closet installations.

### Minimum opening dimensions

a	28 in.
b	23 7/8 in.
c	34 1/2 in.

### E & F are minimum area sizes

E	63 sq. in.
F	63 sq. in.

### G & H actual spacing dimensions for min. open area sizes

G	3 in.
H	14 in.

For help and assistance with Bosch accessories please call 1-800-944-2904 Mon-Fri 8am to 6pm EST

Notes: All height, width and depth dimensions are shown in inches. BSH reserves the absolute and unrestricted right to change product materials and specifications, at any time, without notice. Consult the product's installation instructions for final dimensional data and other details prior to making cutout. Applicable product warranty can be found in accompanying product literature or you may contact your account manager for further details.

Warranties: Bosch warrants that the Product is free from defects in materials and workmanship for a period of three hundred and sixty-five (365) days from the date of purchase. The foregoing timeline begins to run upon the date of purchase, and shall not be stalled, tolled, extended, or suspended, for any reason whatsoever. This Product is also warranted to be free from cosmetic defects in material and workmanship (such as scratches of stainless steel, paint/porcelain blemishes, chip, dents, or other damage) to the finish of the Product, for a period of thirty (30) days from the date of purchase or closing date for new construction. This cosmetic warranty excludes slight color variations due to inherent differences in painted and porcelain parts, as well as differences caused by kitchen lighting, product location, or other similar factors. This cosmetic warranty specifically excludes any display, floor, "As Is", or "B" stock appliances.

For more information on our entire line of products, go to [www.bosch-home.ca](http://www.bosch-home.ca) or call 1-800-944-2904

© BSH Home Appliances Limited. All rights reserved. Bosch is a registered trademark of Robert Bosch GmbH.