

600 CFM Inline Blower

Downdraft Ventilation – DHG6015NUC

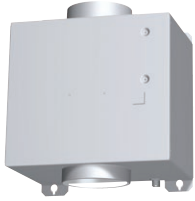

DHG6015NUC

600 CFM inline blower.

Features & Benefits

For use with Bosch downdrafts.

Inline blowers can be mounted remotely to minimize blower noise in the cooking area.

Designed to be mounted inline with the ducting installation.

Blower is mounted on roof of exterior wall depending on application needs.

6" transition required (DHZDHR6)

General Properties

Operating mode	Ducted
Maximum CFM	600 CFM
Number of speed settings	3-stage
Motor location	Inline blower

Technical Details

Watts (W)	530 W
Volts (V)	120 V
Frequency (Hz)	60 Hz
Plug type	No plug
Power cord length (in.)	30"



Dimensions & Weight

Overall appliance dimensions (width of canopy included) (HxWxD) (in.)	15 1/2" / x 14 1/8" x 9 7/8"
Diameter of air duct (in.) top	6"
Diameter of air duct (in.) back	6"
Net weight (lbs)	20 lbs

Accessories-Required

25 ft. blower connector cable	EXTNCB25
-------------------------------	----------



DHZDHR6
6" duct transition

NOTE: Required with the installation of inline and remote blowers for downdraft applications only. DHZDHR6 is for 600 CFM which will improve overall performance.

For help and assistance with Bosch accessories please visit: www.bosch-eshop.com/eshop/bosch/us or call 1-800-944-2904 Mon-Fri 5am to 6pm PST Sat 6am to 3pm PST

Notes: All height, width and depth dimensions are shown in inches. BSH reserves the absolute and unrestricted right to change product materials and specifications, at any time, without notice. Consult the product's installation instructions for final dimensional data and other details prior to making cutout. Applicable product warranty can be found in accompanying product literature or you may contact your account manager for further details.

Warranties: Bosch warrants that the Product is free from defects in materials and workmanship for a period of three hundred and sixty-five (365) days from the date of purchase. The foregoing timeline begins to run upon the date of purchase, and shall not be stalled, tolled, extended, or suspended, for any reason whatsoever. This Product is also warranted to be free from cosmetic defects in material and workmanship (such as scratches of stainless steel, paint/porcelain blemishes, chip, dents, or other damage) to the finish of the Product, for a period of thirty (30) days from the date of purchase or closing date for new construction. This cosmetic warranty excludes slight color variations due to inherent differences in painted and porcelain parts, as well as differences caused by kitchen lighting, product location, or other similar factors. This cosmetic warranty specifically excludes any display, floor, "As Is", or "B" stock appliances.

For more information on our entire line of products, go to www.bosch-home.com/us or call 1-800-944-2904

© BSH Home Appliances Corporation. All rights reserved. Bosch is a registered trademark of Robert Bosch GmbH.

06/16

600 CFM Inline Blower

Downdraft Ventilation – DHG6015NUC



Installation Details

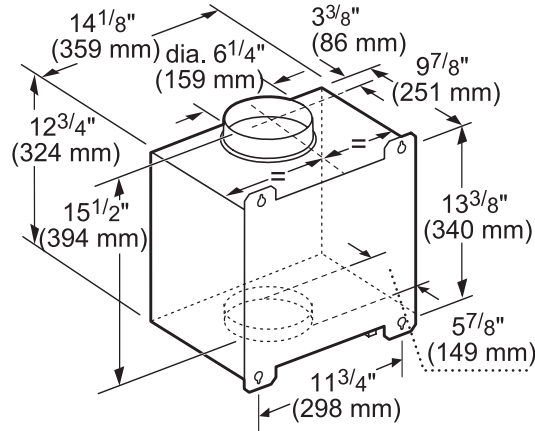

measurements in inches and mm

For help and assistance with Bosch accessories please visit: www.bosch-eshop.com/eshop/bosch/us or call 1-800-944-2904 Mon-Fri 5am to 6pm PST Sat 6am to 3pm PST

Notes: All height, width and depth dimensions are shown in inches. BSH reserves the absolute and unrestricted right to change product materials and specifications, at any time, without notice. Consult the product's installation instructions for final dimensional data and other details prior to making cutout. Applicable product warranty can be found in accompanying product literature or you may contact your account manager for further details.

Warranties: Bosch warrants that the Product is free from defects in materials and workmanship for a period of three hundred and sixty-five (365) days from the date of purchase. The foregoing timeline begins to run upon the date of purchase, and shall not be stalled, tolled, extended, or suspended, for any reason whatsoever. This Product is also warranted to be free from cosmetic defects in material and workmanship (such as scratches of stainless steel, paint/porcelain blemishes, chip, dents, or other damage) to the finish of the Product, for a period of thirty (30) days from the date of purchase or closing date for new construction. This cosmetic warranty excludes slight color variations due to inherent differences in painted and porcelain parts, as well as differences caused by kitchen lighting, product location, or other similar factors. This cosmetic warranty specifically excludes any display, floor, "As Is", or "B" stock appliances.

For more information on our entire line of products, go to www.bosch-home.com/us or call 1-800-944-2904

© BSH Home Appliances Corporation. All rights reserved. Bosch is a registered trademark of Robert Bosch GmbH.

06/16