

24" Bar Handle Dishwasher

800 Plus Series- Stainless steel

SHX9ER55UC



Features and Benefits

Key Features

- 39 dBA- Quietest in North America
- 3rd Rack for Additional Loading Capacity
- ActiveTab™ Tray Optimizes Detergent Dissolving
- Water Softener Ensures Perfect Cleaning Results
- AquaStop® Plus 4-Part Leak Protection Works 24/7
- Load Size Sensor Automates Wash Temperature

Design

- Stainless Steel TallTub
- Red Remaining Time Display

Performance

- 39 dBA- Quietest in North America
- InfoLight® Beams on Floor to Indicate Dishwasher is Running
- 4 Wash Cycles and 2 Options
- Sanitize Option eliminates bacteria and enhances drying results
- Variable Spray Pressure
- ActiveTab™ Tray Optimizes Detergent Dissolving
- Water Softener Ensures Perfect Cleaning Results
- Load Size Sensor Automates Wash Temperature

Efficiency

- Saves up to 599 gallons of water each year
- EcoSense™ Reduces Energy Usage by up to 20%
- Half Load Option for Small Loads

Convenience

- AquaStop® Plus 4-Part Leak Protection Works 24/7
- Multi-Function LED with Remaining Time

Notes: All height, width and depth dimensions are shown in inches. *Please refer to installation instructions prior to making cutout. BSH reserves the absolute and unrestricted right to change product materials and specifications, at any time, without notice. Consult the product's installation instructions for final dimensional data and other details. Applicable product warranty can be found in a accompanying product literature or you may contact your account manager for further details.

For more information on our entire line of products, go to boschappliances.com or call 1-800-944-2904.
Copyright ©2017 BSH Home Appliances Corporation. All rights reserved. Bosch is a registered trademark of Robert Bosch GmbH.

Litho Date: 10/2017



24" Bar Handle Dishwasher 800 Plus Series- Stainless steel SHX9ER55UC

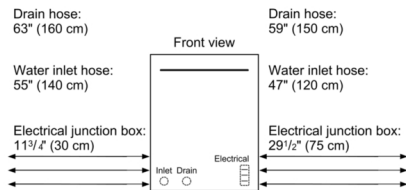

All connections are at the rear of the appliance.
Extension for drain hose available as accessory.
Power cord for connection to electrical outlet (3-prong plug) available as accessory.

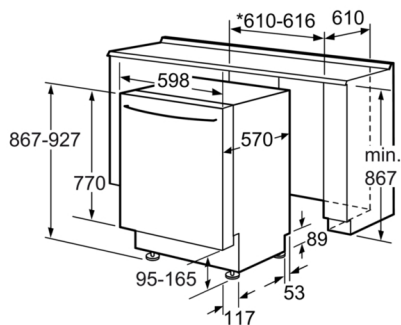

* 600 without decor strips
Measurements in mm

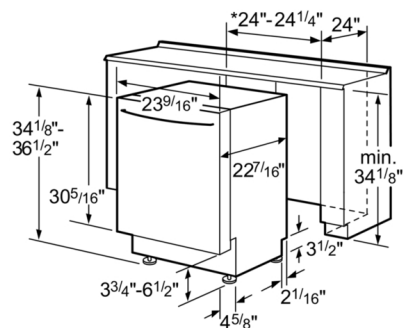

* 23 5/8" without decor strips
measurements in inches

Features

Watts (W)	1300
Current (A)	12
Volts (V)	120
Frequency (Hz)	60
Power Cord Length	47 1/4"
Minimum Water Pressure (lb/sin)	7.0
Length inlet hose (in)	55 1/8"
Length outlet hose (in)	55 1/8"
Overall appliance dimensions (HxWxD) (in)	34 1/8" x 23 9/16" x 23 9/16"
Required cutout size (HxWxD) (in)	x 34 1/8" x 23 9/16"
Adjustable feet	Yes

Technical Specification

Number of wash cycles	5
Number of options	6
Third Rack	3rd Rack 1.0
Tub material	Stainless steel
Concealed heating element	Yes
Leak protection system	24/7 Aqua Stop Plus
Five-level wash	Yes
Water softener	Yes
ChildLock	No
Total annual energy consumption (kWh)	200
Energy Efficiency Class	
Energy Star® qualified	No
Total annual energy consumption (kWh)	
Total annual water consumption (g)	
Number of place settings	14

Notes: All height, width and depth dimensions are shown in inches. *Please refer to installation instructions prior to making cutout. BSH reserves the absolute and unrestricted right to change product materials and specifications, at any time, without notice. Consult the product's installation instructions for final dimensional data and other details. Applicable product warranty can be found in a accompanying product literature or you may contact your account manager for further details.

For more information on our entire line of products, go to boschappliances.com or call 1-800-944-2904.
Copyright ©2017 BSH Home Appliances Corporation. All rights reserved. Bosch is a registered trademark of Robert Bosch GmbH.

Litho Date: 10/2017

