

30" Electric Cooktop

500 Series – Black Frameless NEM5066UC

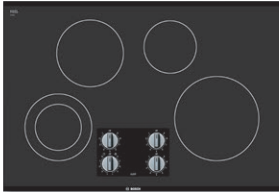

NEM5066UC
Black

The 500 Series electric cooktop is sleek in design, and features optimal temperature control for better cooking results.

Features & Benefits

Precise temperature control for better cooking results.

Ceramic glass surface makes cooking and cleaning especially easy.

Residual heat indicator – warns if cooktop is warm or hot.

Push-to-turn control knobs.

Dual element offers the capability to use multiple pan sizes.

General Properties

Knob material Plastic

Element Performance

Power of Front Left heating element 1,700 / 700 W

Power of Back Left heating element 1,800 W

Power of Back Right heating element 1,200 W

Power of Front Right heating element 2,500 W

Element Size

Dimension of Front Left heating element 7", 5"

Dimension of Back Left heating element 7"

Dimension of Back Right heating element 6"

Dimension of Front Right heating element 9"

Technical Details

Watts 7,200 W

Circuit breaker 30 A

Volts 208-240 V

Frequency 60 Hz

Plug type No plug

Energy source Electric

Dimensions & Weight

Overall appliance dimensions (HxWxD) 1/4" +4" x 31" x 21 1/4"

Required cutout size (HxWxD) 4" x 28 7/8" x 20"

Minimum distance from counter front 2 1/4"

Minimum distance from rear wall 2"

Net weight 25 lbs

Accessories—Optional



HEZ390210
8" AutoChef® pan



HEZ390220
9" AutoChef® pan



HEZ390230
10" AutoChef® pan



For help and assistance with Bosch accessories please call 1-800-944-2904 Mon-Fri 8am to 6pm EST

Notes: All height, width and depth dimensions are shown in inches. BSH reserves the absolute and unrestricted right to change product materials and specifications, at any time, without notice. Consult the product's installation instructions for final dimensional data and other details prior to making cutout. Applicable product warranty can be found in accompanying product literature or you may contact your account manager for further details.

Warranties: Bosch warrants that the Product is free from defects in materials and workmanship for a period of three hundred and sixty-five (365) days from the date of purchase. The foregoing timeline begins to run upon the date of purchase, and shall not be stalled, tolled, extended, or suspended, for any reason whatsoever. This Product is also warranted to be free from cosmetic defects in material and workmanship (such as scratches of stainless steel, paint/porcelain blemishes, chip, dents, or other damage) to the finish of the Product, for a period of thirty (30) days from the date of purchase or closing date for new construction. This cosmetic warranty excludes slight color variations due to inherent differences in painted and porcelain parts, as well as differences caused by kitchen lighting, product location, or other similar factors. This cosmetic warranty specifically excludes any display, floor, "As Is", or "B" stock appliances.

For more information on our entire line of products, go to www.bosch-home.ca or call 1-800-944-2904

© BSH Home Appliances Limited. All rights reserved. Bosch is a registered trademark of Robert Bosch GmbH.

05/16

30" Electric Cooktop

500 Series – Black Frameless NEM5066UC



Installation Details

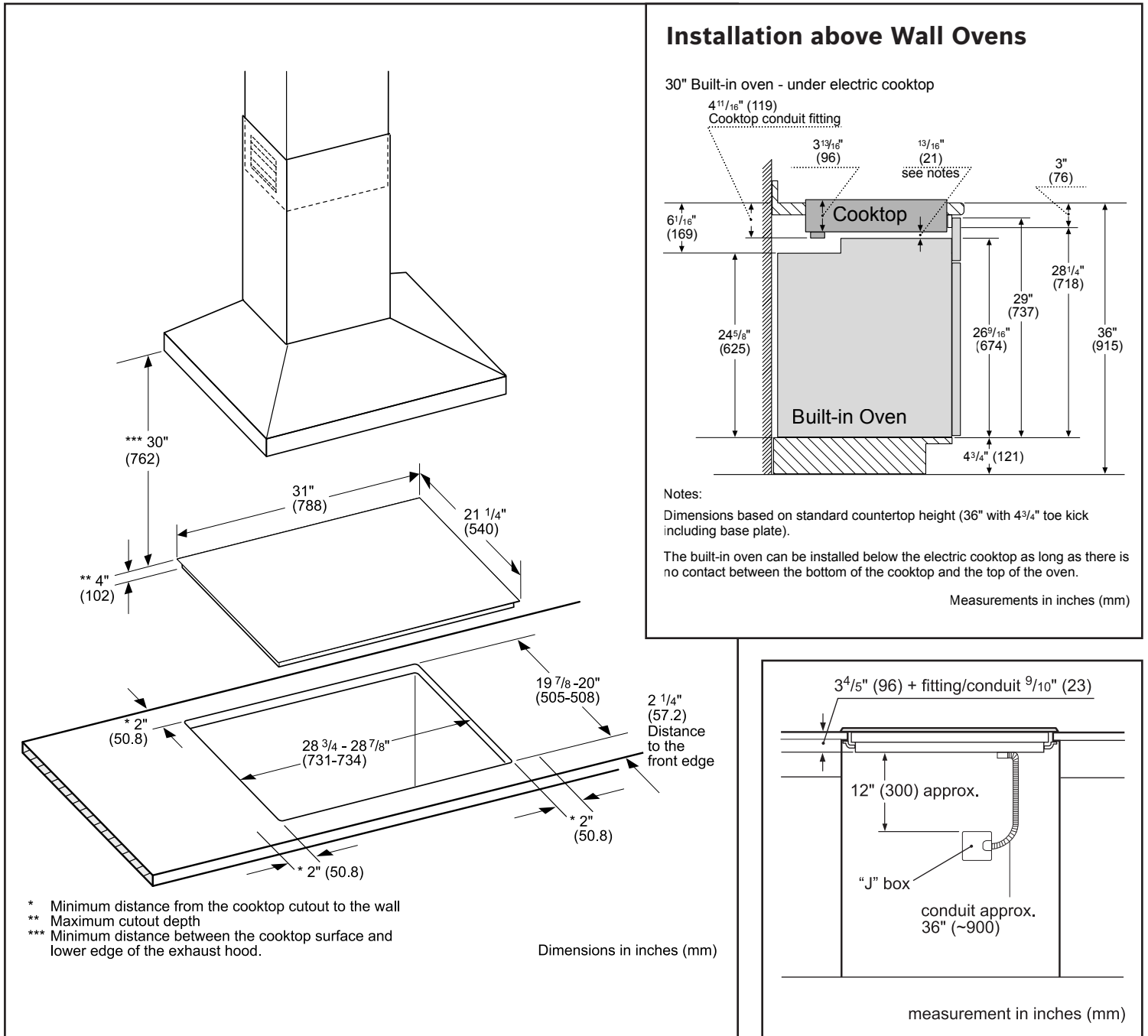

For help and assistance with Bosch accessories please call 1-800-944-2904 Mon-Fri 8am to 6pm EST

Notes: All height, width and depth dimensions are shown in inches. BSH reserves the absolute and unrestricted right to change product materials and specifications, at any time, without notice. Consult the product's installation instructions for final dimensional data and other details prior to making cutout. Applicable product warranty can be found in accompanying product literature or you may contact your account manager for further details.

Warranties: Bosch warrants that the Product is free from defects in materials and workmanship for a period of three hundred and sixty-five (365) days from the date of purchase. The foregoing timeline begins to run upon the date of purchase, and shall not be stalled, tolled, extended, or suspended, for any reason whatsoever. This Product is also warranted to be free from cosmetic defects in material and workmanship (such as scratches of stainless steel, paint/porcelain blemishes, chip, dents, or other damage) to the finish of the Product, for a period of thirty (30) days from the date of purchase or closing date for new construction. This cosmetic warranty excludes slight color variations due to inherent differences in painted and porcelain parts, as well as differences caused by kitchen lighting, product location, or other similar factors. This cosmetic warranty specifically excludes any display, floor, "As Is", or "B" stock appliances.

For more information on our entire line of products, go to www.bosch-home.ca or call 1-800-944-2904

© BSH Home Appliances Limited. All rights reserved. Bosch is a registered trademark of Robert Bosch GmbH.

05/16